

HENDERSON

NEW
PRODUCTS
INSIDE

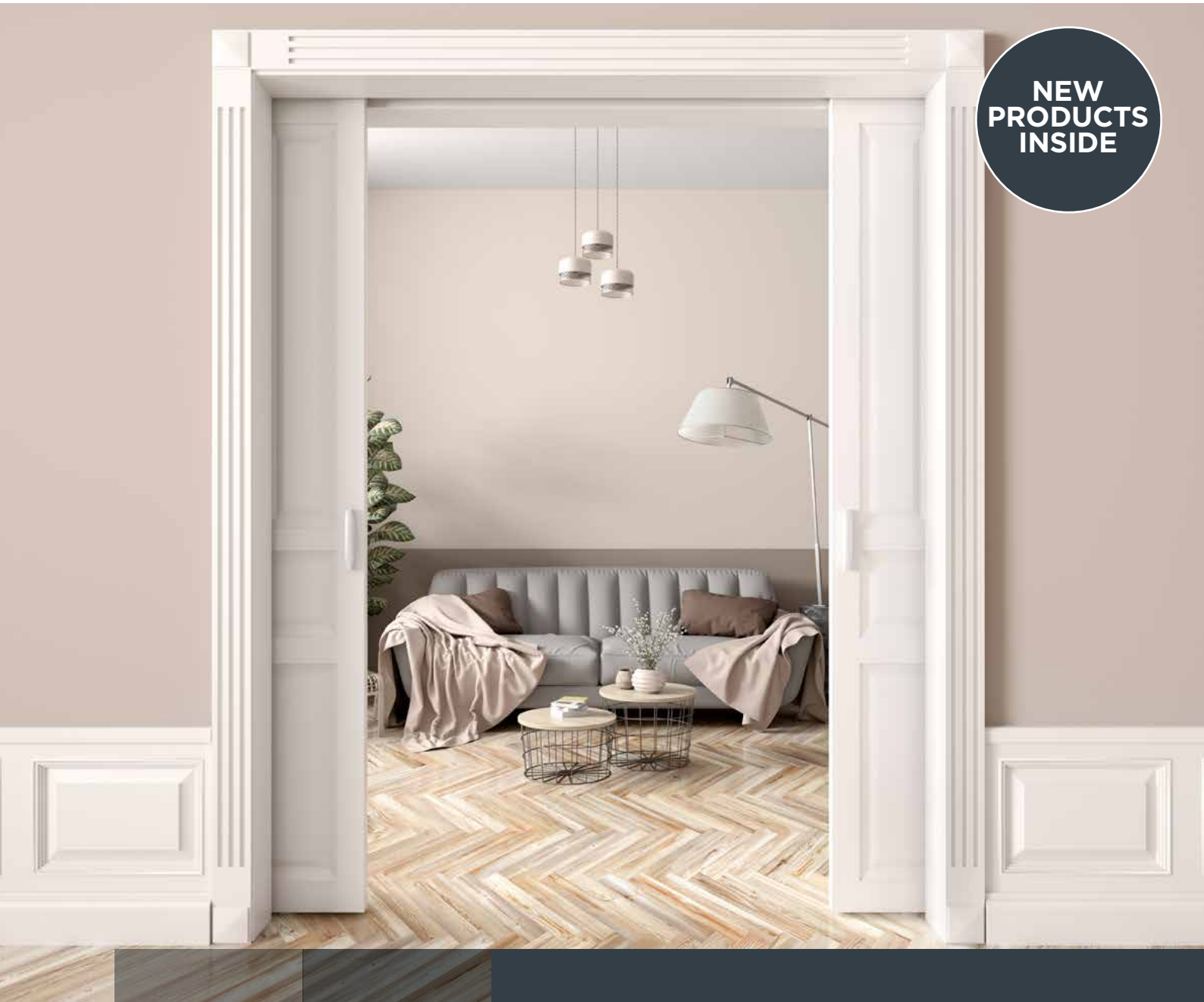

Sliding and Folding Door Hardware **The Complete Product Range**

Volume 3



HENDERSON

Making things slide since 1921

Established in 1921, P C Henderson has been creating the highest quality sliding and folding door hardware for almost 100 years. Our products can be seen in a wide variety of residential, commercial and industrial applications across the world.

Our expertly designed hardware systems are perfect for saving space, increasing natural light, creating flexible spaces and providing hard-wearing solutions for virtually any type of application.

Applications include pocket doors, wardrobes, room dividers, disability access, exterior doors, shop fronts, offices, shutter systems, large industrial doors as well as bespoke systems. Wherever a sliding or folding door can work, we offer a solution.



Based in Co. Durham, UK our manufacturing plant is one of the most advanced of its kind, constantly achieving strict ISO 9001 quality standards. We also have offices in Ireland, the Netherlands and China along with an extensive network of distributors and representatives across the globe, exporting to over 70 countries worldwide.



For almost 100 years P C Henderson has been providing a wide a range of high quality, cost effective sliding and folding door hardware, backed up by exceptional customer service and unrivalled expertise.

CONTENTS

Sliding

Product	Application	Door Material	Door Weight Position	Max. Door Weight	Page No.
Slipper	Interior	Wood	Top Hung	9kg	10
Loretto	Interior	Wood	Bottom Rolling	23kg	11
Cello	Interior	Wood	Bottom Rolling	25kg	12
Zenith	Interior	Glass	Bottom Rolling	25kg	13
Senator	Interior	Wood	Top Hung	30kg	14
Phantom	Interior	Wood	Top Hung	45kg	15
Single Top	Interior	Wood	Top Hung	45kg	16
Double Top	Interior	Wood	Top Hung	45kg	17
Mansion 55	Interior	Wood	Bottom Rolling	55kg	18 - 19
Pocket Door	Interior	Wood	Top Hung	60kg	20 - 21
Husky Glass	Interior	Glass	Top Hung	50kg/75kg	22 - 23
Husky Telescopic	Interior	Wood	Top Hung	80kg	24
Sirocco	Interior	Wood/Metal	Top Hung	80kg	25
Rustic 100	Interior	Wood/Metal	Top Hung	100kg	26
Rustic Top Mount	NEW Interior	Wood/Metal	Top Hung	100kg	27
Marathon	Interior	Wood	Top Hung	55kg/90kg	28
Marathon Fire Rated	Interior	Wood	Top Hung	90kg	29
Husky Sliding	Interior	Wood/Metal	Top Hung	50kg/100kg	30 - 31
Husky Low Headroom	Interior	Wood	Top Hung	100kg	32
Husky Soft Stop	NEW Interior	Wood/Metal	Top Hung	100kg	33
Pocket Door Pro	NEW Interior	Wood	Top Hung	120kg	34 - 35
Pocket Door Pro Fire Rated For Single Doors	NEW Interior	Wood	Top Hung	120kg	36 - 37
Pocket Door Pro Fire Rated For Bi-Parting Doors	NEW Interior	Wood	Top Hung	120kg	38 - 39
Soltaire Telescopic	Interior	Wood	Top Hung	120kg	40
Sienna	Interior	Wood	Top Hung	120kg	41
Sienna Glass	Interior	Glass	Top Hung	120kg	42
Pacer Glass	Interior	Glass	Top Hung	130kg/180kg	43
Pacer Sliding	Interior/Exterior	Wood/Metal	Top Hung	200kg	44 - 45
Imperial	Interior/Exterior	Wood/Metal	Bottom Rolling	100kg/200kg	46 - 47
Soltaire	Interior/Exterior	Wood/Metal	Top Hung	120kg/180kg/250kg	48 - 49
Soltaire Soft Close	Interior	Wood/Metal	Top Hung	80kg	50
Soltaire Low Headroom	Interior/Exterior	Wood	Top Hung	120kg/180kg/250kg	51
Stainless Steel	Interior/Exterior	Wood/Metal	Top Hung	50kg/100kg/150kg/270kg	52 - 53
Majestic	Interior/Exterior	Wood	Bottom Rolling	270kg	54 - 55
Flexirol Sliding	Interior/Exterior	Wood/Metal	Top Hung	500kg	56 - 57
Flexirol Sliding Glass	Interior	Glass	Top Hung	500kg	58 - 59
Straight Sliding 290, 301, 301H, 305, 307	Interior/Exterior	Wood/Metal	Top Hung	150kg/200kg/300kg/ 400kg/450kg/700kg/2000kg	60 - 63
Sterling	Interior/Exterior	Wood/Metal	Bottom Rolling	350kg/800kg/2000kg/ 3600kg/8000kg	64 - 66
Overhead Runway Gear	Interior/Exterior	-	Top Hung	Variety of door weights	67

Folding

Product	Application	Door Material	Door Weight Position	Max. Door Weight	Page No.
Bifold	Interior	Wood	Top Hung	14kg	70
Roomflex	Interior	Wood	Top Hung	35kg/50kg	71
Husky Folding	Interior	Wood	Top Hung	25kg/40kg	72 - 73
Pacer Endfold	Interior	Wood/Metal	Top Hung	35kg/65kg	74 - 75
Tangent Folding	Interior/Exterior	Wood/Metal	Top Hung	35kg/55kg/70kg	76 - 77
Pacer Centrefold	Interior	Wood	Top Hung	35kg/75kg	78 - 79
Soltaire Endfold	Interior/Exterior	Wood/Metal	Top Hung	45kg/75kg	80 - 81
Soltaire Centrefold	Interior/Exterior	Wood/Metal	Top Hung	45kg/75kg	82 - 83
Securefold Bottom Rolling	Interior/Exterior	Wood	Bottom Rolling	80kg	84 - 87
Council Centrefold	Interior	Wood	Top Hung	35kg/55kg/70kg/80kg	88 - 89
Council Endfold	Interior	Wood	Top Hung	35kg/55kg/70kg/80kg	90 - 91
Flexirol Endfold	Interior/Exterior	Wood/Metal	Top Hung	125kg	92 - 93
Flexirol Centrefold	Interior	Wood	Top Hung	125kg	94
Securefold	Interior/Exterior	Wood	Top Hung	50kg/100kg/150kg	95 - 100

Multidirectional

Product	Application	Door Material	Door Weight Position	Max. Door Weight	Page No.
Flexirol Multidirectional	Interior/Exterior	Wood/Metal	Top Hung	100kg/500kg	102 - 103
Flexirol Multidirectional Glass	Interior	Glass	Top Hung	100kg/250kg/500kg	104 - 106

Round the Corner

Product	Application	Door Material	Door Weight Position	Max. Door Weight	Page No.
Tangent Round the Corner	Interior/Exterior	Wood/Metal	Top Hung	35kg/55kg/70kg	108 - 109

Automated

Product	Application	Door Material	Door Weight Position	Max. Door Weight	Page No.
Evolve	Interior	Wood/Metal/Glass	Top Hung	80kg	112 - 113
Evolve Pocket Door Pro NEW	Interior	Wood	Top Hung	80kg	114 - 115

Shutters

Product	Application	Door Material	Door Weight Position	Max. Door Weight	Page No.
Shutter Slide NEW	Exterior	Wood/Metal	Top Hung	120kg	118 - 119

Folding Door Configurations and Quantities

	Page No.
Interior Centre Folding Systems	121
Interior End Folding Systems	122 - 125

Commercial Component Drawings

	Page No.
Tracks, Intersects and Curves	126
Brackets	126
Hangers	127
Pivot Sets	128
Guides	128
Guide Channels	128
Accessories and Stops	128

Industrial Component Drawings

	Page No.
Tracks	129
Brackets	130
Hangers	131
Channels and Rails	132

Stainless Steel Component Drawings

	Page No.
Track, Guide Channel and Guides	133
Brackets and Stops	134
Hangers	135

Accessories

	Page No.
Soft Close Kits	136
Simultaneous Actions Kits NEW	136
Self Close Kits NEW	136
Flush Pulls and Finger Pulls NEW	136
Handles	137
Locks NEW	137
Flush Bolts	138
Twinbolt	138
Track Stops	138
Door Stops	139
Fantom Magnetic Door Stop NEW	139
Door Magnets	139
Bolts	140
Fascias	140
Automated Door Accessories	140

WHY P C HENDERSON

Our People

Our customer service and technical support team is made up of a group of knowledgeable, passionate and long standing individuals. With extensive experience working on projects of all sizes across the world, the team possess the knowledge and experience required to specify even the most complex and ambitious of projects.



Impressive Product Range

From small 9kg sliding hatch doors to 8000kg large industrial doors - our range of hardware caters for projects of all sizes. With over 60 different hardware products, interior and exterior options, top hung and bottom rolling support options, along with a huge range of accessories - our vast product range is difficult to surpass. Wherever a sliding or folding door can work, we offer a solution.

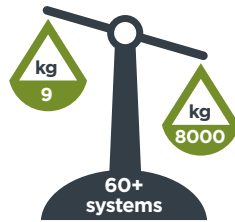

Designing and Manufacturing Since 1921

As a designer and manufacturer of sliding door hardware since 1921, it's safe to say that our expertise in this area is of the highest standard. Our offices, people, technology, materials and tooling may have all changed over the course of almost a century but the Henderson ethos of how we design and manufacture our products has remained the same and is testament to our success today. P C Henderson manufactures to strict quality standards of BS EN ISO 9001.



Research and Development

Continual investment into the research and development of our product range is extremely important. Part of this research is customer engagement - hearing the voice of the customer first hand is vital to the success of our products. We use this valuable feedback to continually adapt, enhance and add to our existing product range to make sure we meet and exceed customer expectations.

Product Testing

Our in house, state of the art testing facilities allows us to put each and every one of our products through rigorous testing prior to release. Each component we design is put through a Finite Element Analysis, this process applies virtual forces to the product to see where modifications may be required before the product is even built. A prototype is then built and put through a physical test, using specialist machinery, in excess of 100,000 cycles (accredited to BS EN 1527) - this ensures our products are capable of withstanding the test of time.



Environmental Commitment

P C Henderson is committed to achieving and demonstrating compliance with all relevant environmental laws, regulations and standards. We also take our responsibilities to society extremely seriously. Our BS EN ISO 14001 accredited environmental policy sets our commitment to providing products and services that are environmentally sound.



CHOOSE YOUR HARDWARE

USING OUR SIMPLE 10 STEP GUIDE

- 1 Internal or external use?
- 2 Sliding or folding?
- 3 Is the door top hung or bottom rolling?
- 4 Face fixed or soffit fixed track?
- 5 How heavy are the doors?
- 6 What material is the door?
- 7 How many doors do you require?
- 8 What is the opening width?
- 9 Choose your product
- 10 Choose your accessories

EXPERT SPECIFICATION TOOL

Our online Expert Specification Tool will guide you through a number of questions in order to gather all of the information required to specify your hardware. It will then produce a short list of suitable products for you to choose from – simple and easy. www.pchenderson.com/expert

The image displays six screenshots from the Henderson Expert Specification Tool, arranged in a 2x3 grid. Each screenshot shows a step in the configuration process:

- Step 1: Select exterior or interior** - A question about whether the sliding door gear will be exposed to the elements. Options are Exterior and Interior.
- Step 2: Choose the type of gear** - A question about the type of sliding door gear required. Options are Straight sliding, End fixing (selected), and Round the corner.
- Step 3: Select top hung or bottom roller** - A question about how the weight of the door will be supported. Options are Top hung (selected) and Bottom roller.
- Step 4: How will the track be fixed?** - A question about whether the track will be fixed to the face of the opening or the soffit. Options are Face fixed and Soffit fixed (selected).
- Step 5: Enter the dimensions** - A question about the size of the opening. It includes a diagram of a door opening with labels for Depth of frame, Width of frame, Opening height, and Opening width. Below the diagram are input fields for Opening width, Opening height, Left reveal, and Right reveal.
- Step 6: Door configuration** - A question about the door configuration and end folding system. It includes a diagram showing three configurations: Hinged to left post, Floating, and Hinged to right post. Below the diagram are input fields for Number of folding units, Unit 1 finger call, and Unit 2 finger call.

OUR BROCHURE

The entire P C Henderson product range in an easy to follow format

Product Comparison Table

Our contents table on pages 4 and 5 also doubles up as a handy comparison table for easy browsing of our entire product range.

Sections by Operation Type

The brochure is broken down into 6 sections for easy browsing; sliding, folding, multidirectional, round the corner, automated and shutters. These are colour coded for ease of navigation.



Products in Door Weight Order

The products are listed in door weight order within each of the six sections of the brochure.

If the hardware you're looking for will be used to carry lighter doors, start at the beginning of the section. If it will be carrying heavy doors move to the back of the section.

Handy Product Overview Boxes

Operation, door weight, application type and door material - it's all covered in the handy product overview boxes at the top of each page.



Detailed Technical Information

Each product page contains a wealth of technical information and drawings to help specify and put together the right solution for your project. Additional technical information such as CAD drawings, datasheets and fitting instructions can be found on our website.

Kit Packs

Some of our residential and light commercial products are available in a handy kit pack format. This allows you to purchase 'off the shelf' without having to specify individual parts and components.

Look out for our handy kit pack symbol in the top corner of each page.

Installation Videos

The majority of our kit packs come with a handy online installation video to guide you along the process. Look out for the video symbol at the bottom of our kit pack product pages.

You can view the installation videos by typing in the web address or by scanning the QR code using your mobile device.



Watch our installation videos at www.pchenderson.com/installation-videos



Brochure Notes

- All dimensions supplied are in mm
- Most systems can be specified to your unique requirements, contact our technical team for details



Sliding



Catering for maximum door weights of between 9kg and 8000kg, our wide range of sliding door hardware can cater for virtually any type of application or design.

For residential and commercial applications, sliding doors are a great way to save space, open up rooms, increase natural light and provide easy access. For industrial applications such as factories, warehouses and agricultural settings – robust hardware and high levels of security is key.

Available in single sliding, pocket door, bi-parting, telescopic, top hung and bottom rolling variations, our hardware offers huge versatility in terms of functionality and design. Equally as important, the systems are available in a vast array of quality aesthetic finishes and styles whether that be for a sleek and modern design or perhaps a more traditional and period look.

Range Overview

- Over 39 different systems
- Catering for maximum door weights of between 9kg and 8000kg
- Catering for wood, metal and glass doors
- Interior and exterior applications
- Top hung and bottom rolling options
- Fire rated and non fire rated options

www.pchenderson.com

SLIPPER



Watch the Installation Video
pchenderson.com/slipper-installation



For sliding wooden cupboard or hatch doors weighing up to 9kg



Slipper is ideally suited for hatches, cupboards and other applications made from lightweight wood or chipboard. It supports a maximum door weight of 9kg, a maximum door width of 900mm and door thickness of between 16-30mm. Three kits are available giving a maximum opening width of 1800mm, the unit can also easily be top fixed. The nylon sliders and aluminium track ensure quiet and effortless operation, an appealing design and simple-to-remove doors for cleaning and decorating. A fittings kit is available for when an additional door is required.

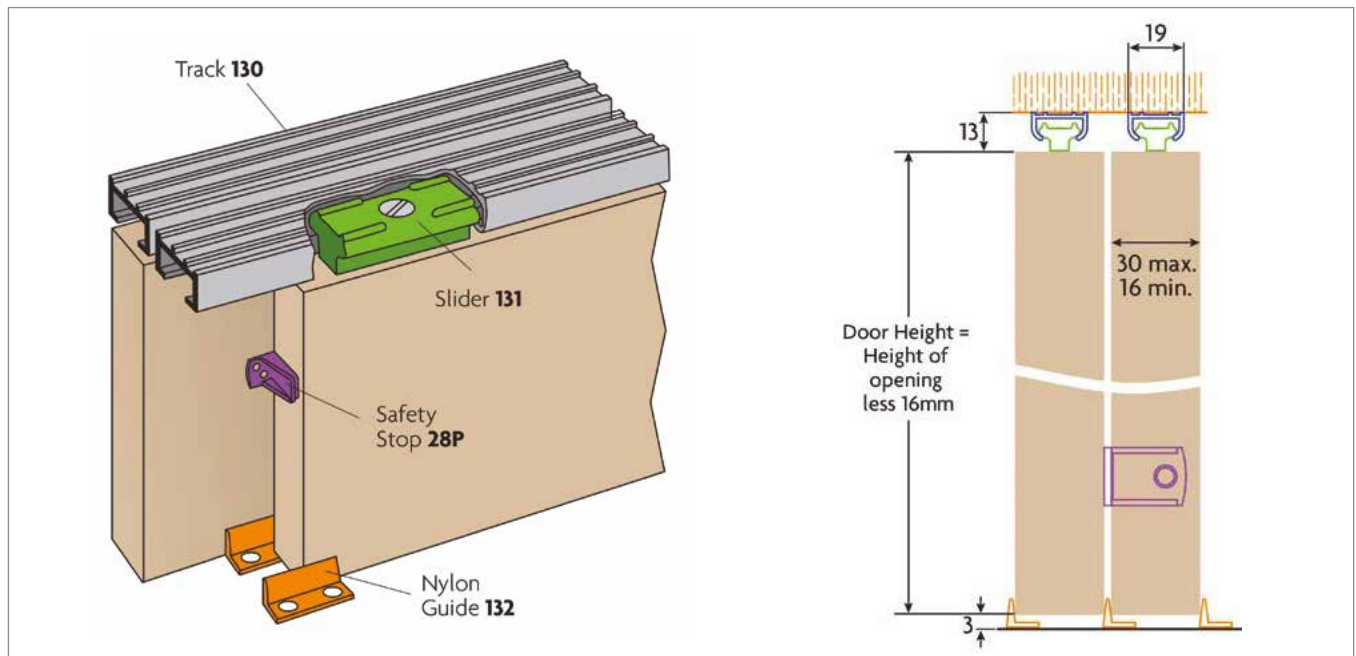

Product Information

Kit Order Code	No. of Doors	Track Length	Max. Door Width	Door Thickness Range	Max. Door Weight
SS4	2	1200mm	900mm	16 - 30mm	9kg
SS5	2	1500mm	900mm	16 - 30mm	9kg
SS6	2	1800mm	900mm	16 - 30mm	9kg
SS1	Fittings kit to be used when an additional door is required				

Kit Contents

Component	Short Code
Track (x 2)	130/****
Sliders (x 4)	131
Stop (x 1)	28P
White Plastic Flush Pull (x 2)	26P
Nylon Guide (x 4)	132

**** Replace by length of track for full short code

Accessories



1 Door Fittings Kit (SS1)

View our
 full range of
 accessories
 on page 136

Components can be specified separately for bespoke projects, contact P C Henderson for details.

LORETTO



Watch the Installation Video
pchenderson.com/loretto-installation



For sliding wooden cupboard doors weighing up to 23kg



When it comes to wardrobes, cupboards, bookcases and other pieces of high quality cabinet work, Loretto is the ideal system. It has been designed to cater for wooden doors weighing up to 23kg, 900mm wide and 20-45mm thick. Using nylon guides and rollers on an aluminium rail, this system is incredibly smooth and quiet. Available in three kits with a maximum opening width of 1800mm.

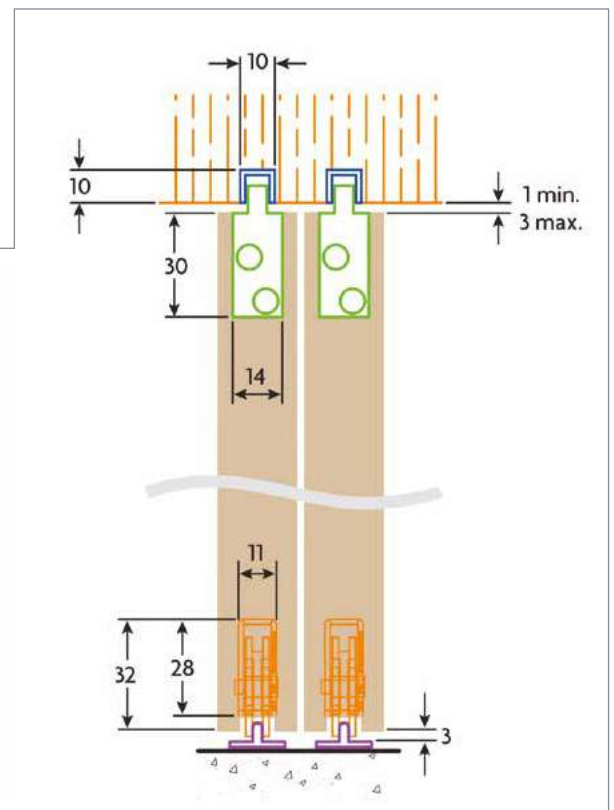
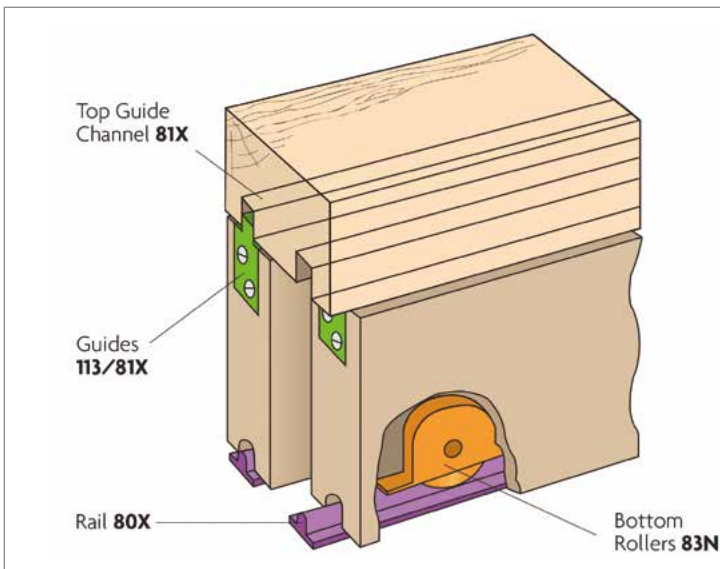

Product Information

Kit Order Code	No. of Doors	Track Length	Max. Door Width	Door Thickness Range	Max. Door Weight
D4	2	1200mm	900mm	20 - 45mm	23kg
D5	2	1500mm	900mm	20 - 45mm	23kg
D6	2	1800mm	900mm	20 - 45mm	23kg

Kit Contents

Component	Short Code
Top Guide Channel (x 2)	81X/****
Top Guides (x 4)	113/81X
Mortise Fixed Bottom Rollers (x 4)	83N
Bottom Rail (x 2)	80X/****

**** Replace by length of track for full short
Components can be specified separately for bespoke projects, contact P C Henderson for details.

Accessories



White Plastic Flush Pull (26P)

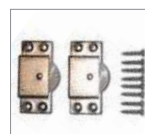

Face Fixed Bottom Rollers (84N)



Door Stop (28P)

View our full range of accessories on page 136

CELLO



Watch the Installation Video
pchenderson.com/cello-installation



For bi-passing wardrobe and cupboard doors weighing up to 25kg



Cello is the perfect system for bottom rolling wooden wardrobe or cupboard doors weighing up to 25kg each. It can support bi-passing doors up to 920mm wide and between 16 - 40mm thick. Two and three door kits are available in order to create opening widths of up to 2400mm. A fittings kit is also available for when an additional door is required.

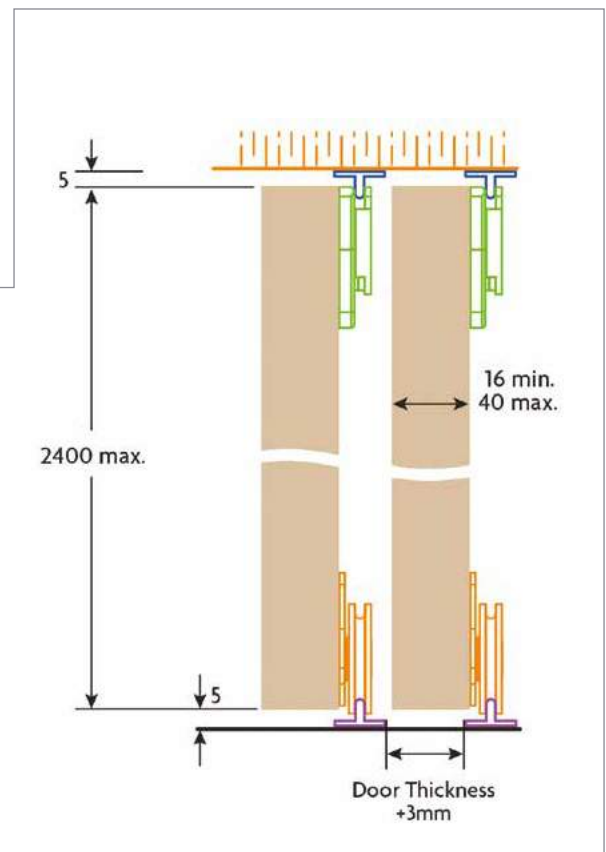
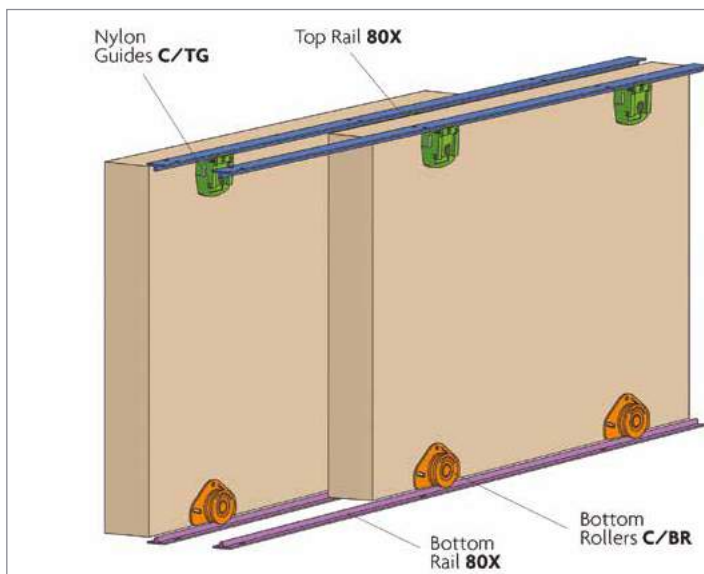

Product Information

Kit Order Code	No. of Doors	Track Length	Max. Door Width	Door Thickness Range	Max. Door Weight
C15	2	1500mm	920mm	16 - 40mm	25kg
C18	2	1800mm	920mm	16 - 40mm	25kg
C24	3	2400mm	920mm	16 - 40mm	25kg
C1	Fittings Kit to be used when an additional door is required				

Kit Contents

Component	Short Code
Bottom Rail (x 4)	80X/****
Top Guide (x 4 for 2 doors/x 6 for 3 doors)	C/TG
Bottom Roller (x 4 for 2 doors/x 6 for 3 doors)	C/BR

**** Replace by length of track for full short code

Components can be specified separately for bespoke projects, contact P C Henderson for details.

Accessories



Rectangle
Flush Pull
(125/S) satin,
also available in
chrome



Oval Flush
Pull (144S)
satin, also
available in black



Door Stop
(28P)



1 Door Fittings
Kit (C1)

View our full range of accessories on page 136

ZENITH

Watch the Installation Video
pchenderson.com/zenith-installation



For sliding glass cupboard doors weighing up to 25kg



Zenith is the perfect partner for any showcase, bookcase, display unit, hatch or interior window which utilises glass doors weighing up to 25kg and measuring 6mm thick. Three kits are available to give a maximum opening width of 1800mm. The system uses precision-made, satin anodised finish aluminium gear and brush pile strips to ensure a silent and easy-gliding action.

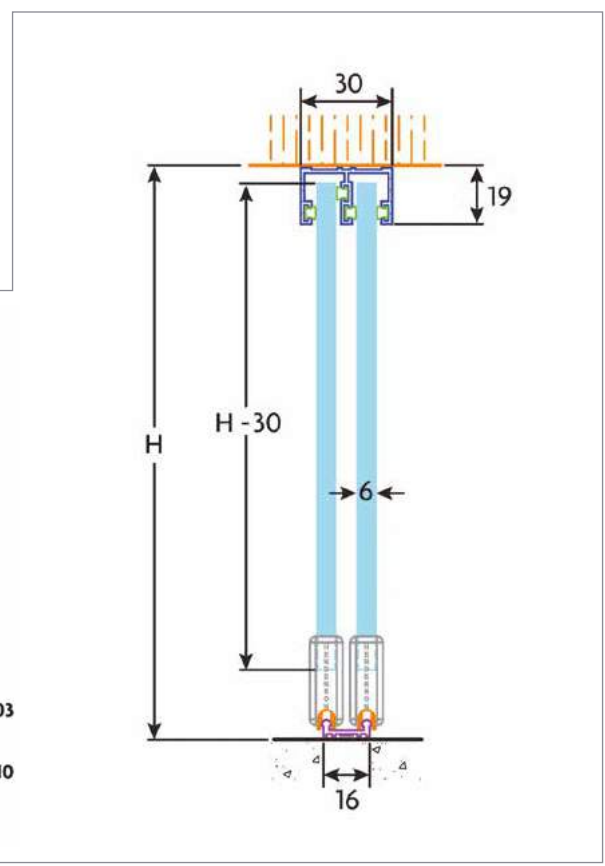
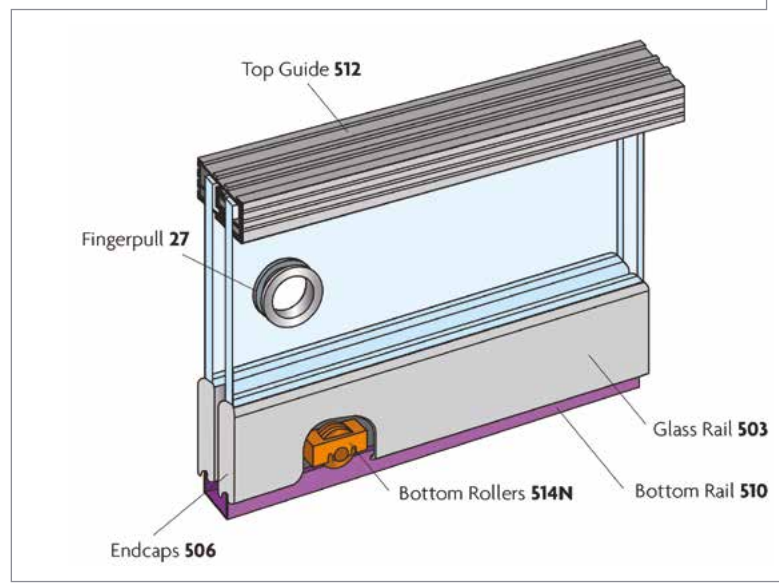

Product Information

Kit Order Code	No. of Doors	Track Length	Max. Door Width	Door Thickness	Max. Door Weight
Z12	2	1200mm	916mm	6mm	25kg
Z15	2	1500mm	916mm	6mm	25kg
Z18	2	1800mm	916mm	6mm	25kg

Kit Contents

Component	Short Code
Top Guide Channel (x 1)	512/****
Glass Rails (x 2)	503/****
Bottom Rollers (x 4)	514/N
End Caps (x 4)	506
Bottom Rail (x 1)	510/****
Glazing Strip (x 2)	509

**** Replace by length of track for full short code

Accessories



Aluminium Finger Pull (27) for glass doors



Cylinder Lock (507) chrome

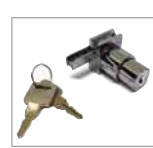

Cylinder Lock (507/120) chrome, keyed alike, key number 120

View our full range of accessories on page 136

Components can be specified separately for bespoke projects, contact P C Henderson for details.

SENATOR



Watch the Installation Video
pchenderson.com/senator-installation



An elegant sliding door mechanism for doors weighing up to 30kg



Senator offers an elegant sliding mechanism for entrance doors and room dividing wooden doors weighing up to 30kg, 900mm wide and between 20-35mm thick. Nylon guides and hangers on an aluminium track with useful fixed floor guides complete this premium package.

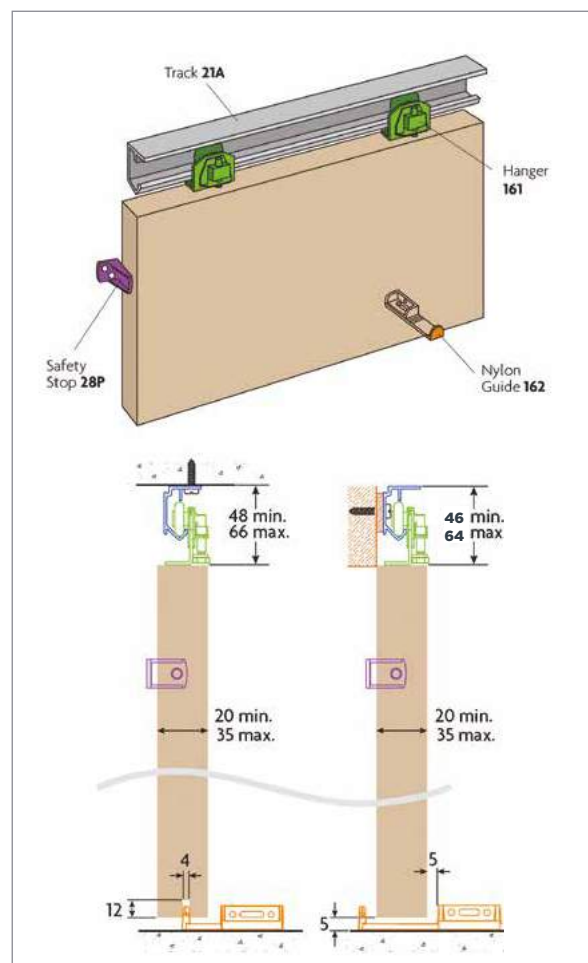

Product Information

Kit Order Code	No. of Doors	Track Length	Max. Door Width	Door Thickness Range	Max. Door Weight
SEN	1	1500mm	900mm	20 - 35mm	30kg

Kit Contents

Component	Short Code
Jump Proof, Face/Soffit Fixing Track (x 1)	21A/1500
Top Fixing Hangers (x 2)	161
Nylon Guide (x 1)	162
Stop (x 1)	28P

Components can be specified separately for bespoke projects, contact P C Henderson for details.

Accessories



Round Flush Pull Set
(385/S) satin, other finishes available



Oval Flush Pull **(144S)**
 satin, also available in black



Easyclose Self Door Closer
(SC100)



Galvanised Steel Fascia
(40P/1854)



Galvanised Steel Fascia End Cap
(EC40P)

View our full range of accessories on page 136

PHANTOM



Watch the Installation Video
pchenderson.com/phantom-installation



For sliding wooden room dividers weighing up to 45kg



If a silent sliding mechanism is a priority, Phantom really delivers. Made for wooden doors weighing up to 45kg, between 610mm - 915mm wide and 30mm - 50mm thick, it can effortlessly divide virtually any room in a variety of environments. Phantom is ultra-quiet, frictionless and easy to operate. Two kits can be used to create a double door specification.

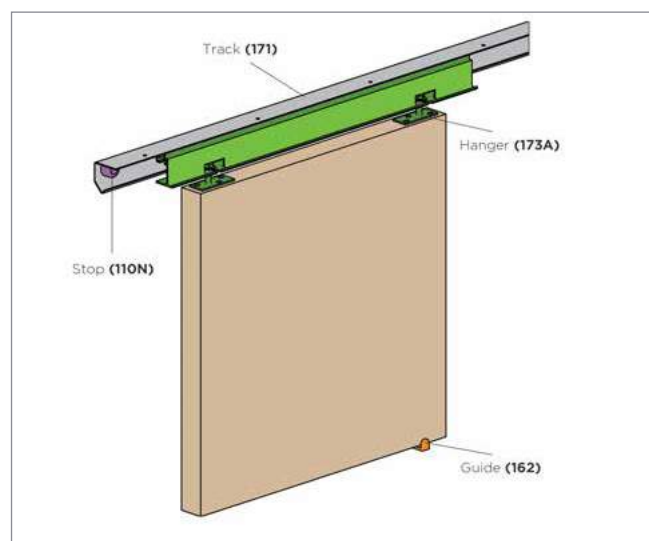

Product Information

Kit Order Code	No. of Doors	Track Length	Door Width Range	Door Thickness Range	Max. Door Weight
P9	1	1525mm	610 - 915mm	30 - 50mm	45kg

Kit Contents

Component	Short Code
Soffit Fixed Track (x 1)	171
Hanger (x 1)	173A
Nylon Guide (x 1)	162
Stop (x 1)	110N

Components can be specified separately for bespoke projects, contact P C Henderson for details.

Accessories



Round Flush Pull Set (**385/S**) satin, also available in chrome, black and polished brass



Square Flush Pull Set (**53/S**) satin, also available in chrome and black



Oval Flush Pull (**144S**) satin, also available in black



Rectangle Flush Pull (**125/S**) satin, also available in chrome

View our full range of accessories on page 136



Floor Mounted Stop (**103**)



Galvanised Steel Fascia (**40P/1854**)



40P End Cap Pack (**EC40P**)



Easyclose Self Door Closer (**SC100**)

SINGLE TOP



Watch the Installation Video
pchenderson.com/single-top-installation



For single sliding wardrobe and cupboard doors weighing up to 45kg



With Single Top, wardrobe doors have never been more graceful. Designed using hangers that fix to the back face of the door, Single Top works with wood, wood framed, MDF and hollow doors. The system caters for doors weighing up to 45kg and between 16mm - 40mm thick. Three kits are available for a maximum width of 900mm. A fittings kit is available for when an extra door is required.

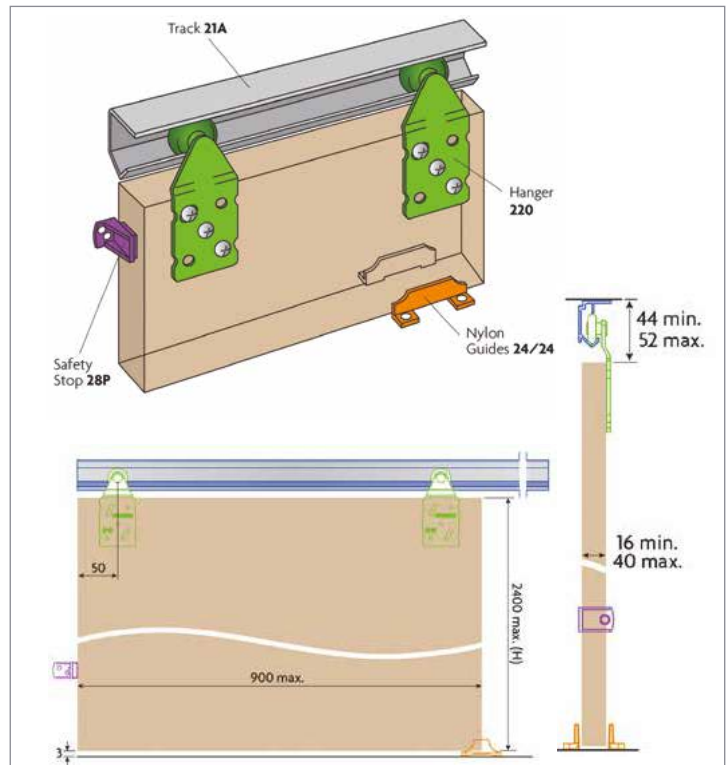

Product Information

Kit Order Code	No. of Doors	Track Length	Max. Door Width	Door Thickness Range	Max. Door Weight
ST12	1	1200mm	600mm	16 - 40mm	45kg
ST15	1	1500mm	750mm	16 - 40mm	45kg
ST18	1	1800mm	900mm	16 - 40mm	45kg
ST01	Fittings kit to be used when an additional door is required				

Kit Contents

Component	Short Code
Anti-Rise, Face/Soffit Fixed Aluminium Track (x 1)	21A/****
Face Fixed Hangers (x 2)	220
Rubber Buffered Stop (x 1)	28P
Nylon Guide (x 1)	24/24

**** Replace by length of track for full short code

Components can be specified separately for bespoke projects, contact P C Henderson for details.

Accessories



Oval Flush Pull (144S) satin, also available in black



Rectangle Flush Pull (125/S) satin, also available in chrome



Aluminium Soffit Fixed Fascia (F134) for doors up to 30mm thick



Fascia End Cap Pack (F134/ECP) for F134 fascia



Guide Channel (81X/****) when a floor mounted guide is required



Guide (113/81X) for 81X channel, 2 per door



1 Door Fittings Kit (ST01)

View our full range of accessories on page 136

DOUBLE TOP



Watch the Installation Video
pchenderson.com/double-top-installation



For sliding wooden bi-passing wardrobe doors weighing up to 45kg



Double Top is perfectly suited for heavy duty sliding wardrobe or cupboard doors. Designed to support double track sliding wooden or MDF doors weighing up to 45kg and 16-40mm thick, the quiet system works on nylon hangers and an aluminium track. Door heights can be adjusted easily, a floor guide can also be added as an option and a fittings kits can be purchased for when an additional 1 or 2 doors are required.

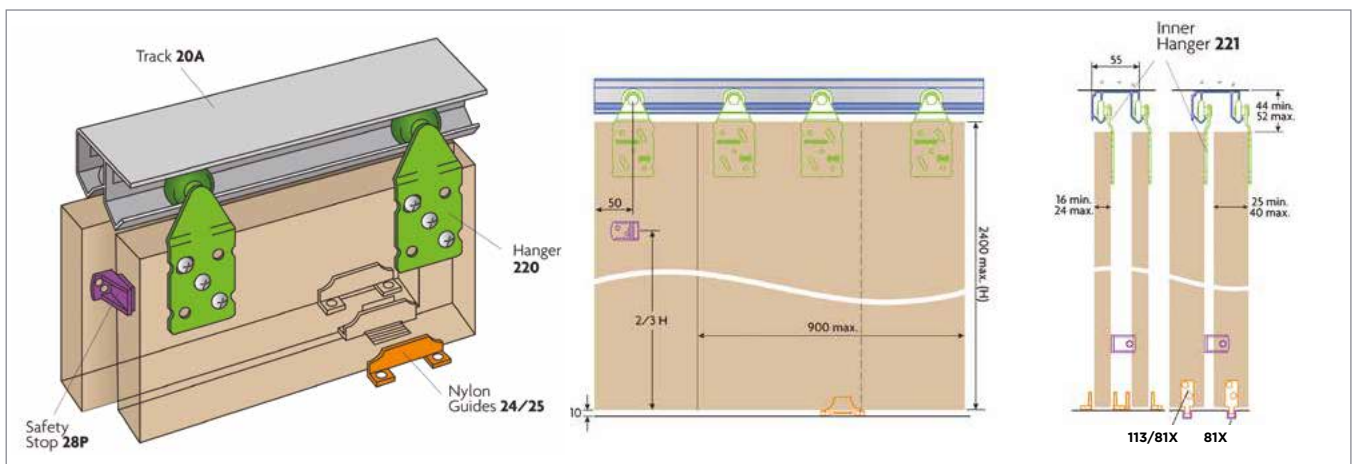

Product Information

Kit Order Code	No. of Doors	Track Length	Max. Door Width	Door Thickness Range	Max. Door Weight
W12	2	1200mm	900mm	16 - 40mm	45kg
W15	2	1500mm	900mm	16 - 40mm	45kg
W18	2	1800mm	900mm	16 - 40mm	45kg
W24	3	2400mm	900mm	16 - 40mm	45kg
W01	Fittings kit to be used when an additional door is required				
W02	Fittings kit to be used when an additional 2 doors are required				

Kit Contents

Component	Short Code
Aluminium Anti-Rise Soffit Fixing Track (x 1)	20A/****
Outer Offset Hangers (x 2)	220
Inner Offset Hangers (x 2)	221
Reversible Hangers (W24 only) (x 2)	222
Rubber Buffered Stop (x 1 for 2 doors/x 2 for 3 doors)	28P
Nylon Guide (x 1 for 2 door/x 2 for 3 doors)	24/25

**** Replace by length of track for full short code

Components can be specified separately for bespoke projects (max. track length 6100mm) contact P C Henderson for details.

Accessories



Oval Flush Pull (144S)
 satin, also available in black



Rectangle Flush Pull (125/S)
 satin, also available in chrome

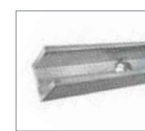

Guide Channel (81X)
 for when a guide channel is required



Aluminium Soffit Fixed Fascia (F134)
 for doors up to 30mm thick



End Cap Pack (F134/ECP)
 for 134 Fascia



1 Door Fittings Kit (W01)



2 Door Fittings Kit (W02)



Guide (113/81X)
 for 81X channel, 2 per door

View our full range of accessories on page 136

MANSION 55

Bottom rolling hardware for internal wooden doors weighing up to 55kg



Mansion 55 is a durable system perfectly suited for high class joinery installations catering for wooden doors weighing up to 55kg each. The product features a concealed bottom roller enabling the weight of the door to be transferred to the floor, making it ideal for when the ceiling or lintel isn't strong enough to support the weight.

NOTE: At least 150mm depth at the bottom of the door must be available to accommodate the concealed bottom rollers when choosing this system.

Product Information

Product	Max. Door Width	Door Thickness Range	Max. Door Weight
Mansion 55	1000mm	30 - 57mm	55kg

Product Specification

Component	Description	Short Code
Top Guide Channel Length should be twice the width of doors	Brass top guide channel in 1500 and 3000mm lengths	94/****
	Aluminium top guide channel in 1500, 2000, 2500, 3000, 4000 and 6000mm lengths	94X/****
Guides 2 per door	Galvanised steel guide with brass roller	113R/94
	Top guide roller	113N/94
	Concealed nylon guide	106N/94
Bottom Roller	Nylon wheeled bottom rollers	913N
Bottom Rail	Mill finish aluminium bottom rail in 1500, 2000, 2500, 3000, 4000 and 6000mm lengths	915A/****
Stop	Floor mounted stop	103
	Double buffer wall mounted stop (2 per door)	107

**** Replace by length of track for full short code

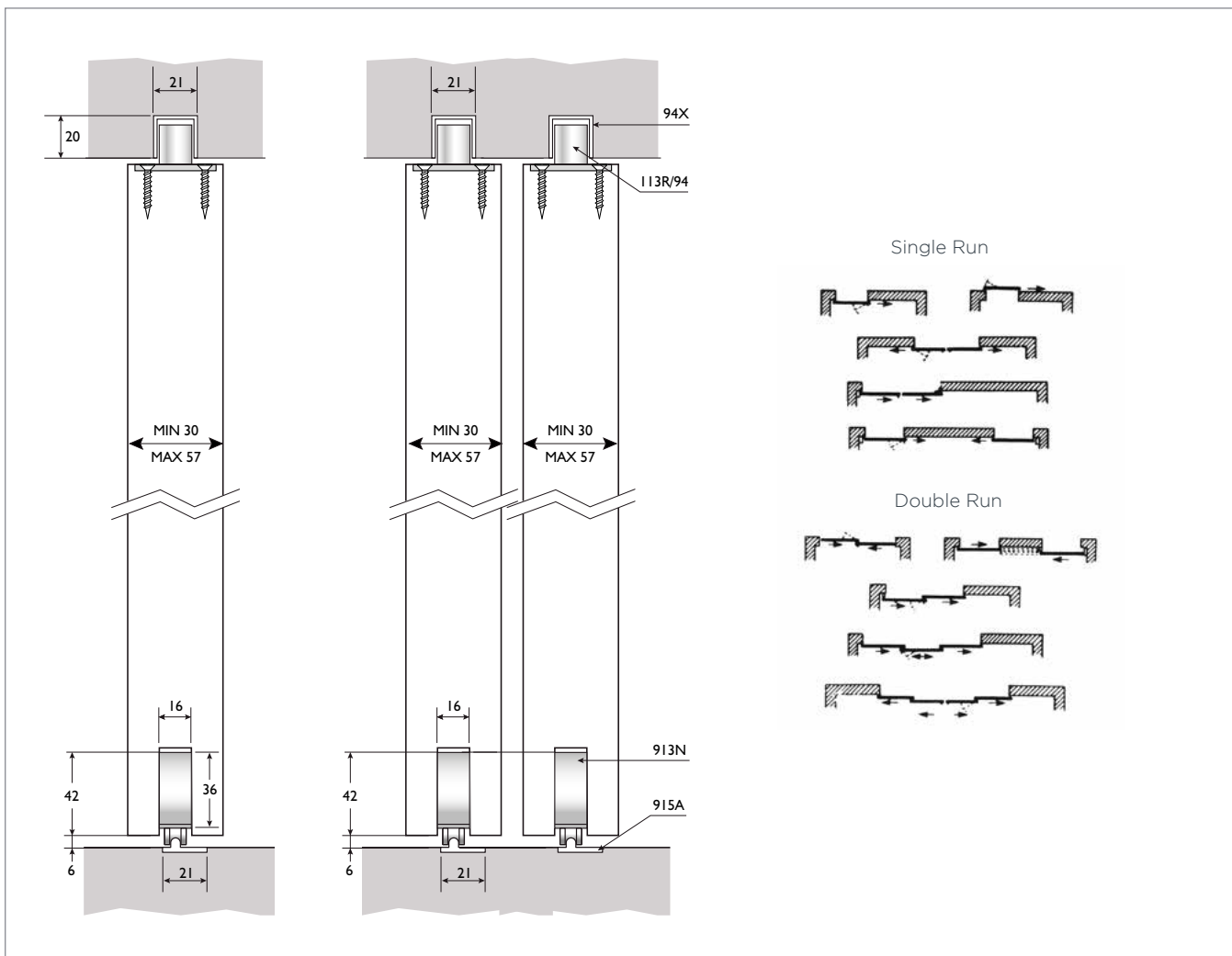

Hardware

Top Guide Channel



94



94X

Guides



113R/94



113N/94



106N/94

Bottom Roller



913N

Bottom Rail



915A

Stops



103



107

Accessories



Round Flush Pull Set (385/S) satin, other finishes available



Square Flush Pull Set (53/S) satin, also available in chrome and black



Oval Flush Pull (144S) satin, also available in black



Rectangle Flush Pull (125/S) satin, also available in chrome



Rectangle Flush Pull (400) SAA, also available in stainless steel



Rectangle Flush Pull (413) cast iron, heavy duty



Rectangle Flush Pull (414) aluminium, heavy duty

View our full range of accessories on page 136

POCKET DOOR

Unique sliding door solution that works with cavity walls for doors weighing up to 60kg



POCKET DOOR PRO

Take a look at the Pro version on page 34

Pocket Door is an innovative sliding door solution which allows a sliding door to disappear into a cavity wall - offering amazing benefits where interior space is limited such as toilets, bathrooms and kitchens.

The system is available as a regular closing system or with the option of a dual soft close and open which catches the door in its final moments of travel and brings it gently into position.

Each Pocket Door kit comes with a timber frame and pre-assembled aluminium track, header mechanism, all sliding components and two satin flush pulls.

For bi-parting pocket doors, two kits can be purchased. A Simultaneous Action Kit is available as an optional extra whereby the user moves one door and the other door will open or close simultaneously. All kits are for a finished wall thickness of 120mm.

For a more professional and robust installation, we also have our Pocket Door Pro system (see page 34). The system has an aluminium frame, rather than timber, providing extra rigidity and durability. Pocket Door Pro is also available in fire rated (page 36) and automated (page 114) versions.

Product Information

Kit Order Code				Max. Door Height	Max. Door Width	Door Thickness Range
Standard Pocket Door (Doors weighing up to 60kg)	Pocket Door with Dual Soft Close (Doors weighing 10 - 20kg)	Pocket Door with Dual Soft Close (Doors weighing 20 - 40kg)	Pocket Door with Dual Soft Close (Doors weighing 40- 60kg)			
PDK3	PDKSOFT3/20	PDKSOFT3/40	PDKSOFT3/60	1981mm	762mm	28 - 44mm
PDK4	PDKSOFT4/20	PDKSOFT4/40	PDKSOFT4/60	1981mm	838mm	28 - 44mm
PDK5	PDKSOFT5/20	PDKSOFT5/40	PDKSOFT5/60	2040mm	762mm	28 - 44mm
PDK6	PDKSOFT6/20	PDKSOFT6/40	PDKSOFT6/60	2040mm	826mm	28 - 44mm
PDK7	PDKSOFT7/20	PDKSOFT7/40	PDKSOFT7/60	2040mm	726mm	28 - 44mm
PDK10	PDKSOFT10/20	PDKSOFT10/40	PDKSOFT10/60	2315mm	930mm	28 - 44mm

Kit Contents

Component	Short Code
Aluminium Track and Soft Wood Header Assembly (pre-fitted) (x 1)	-
Hangers (x 2)	284
Galvanised Steel Wrapped Softwood Studs (x 4)	-
Galvanised Steel Stud Spacing Brackets (x 2)	-
Galvanised Steel Stud Support Brackets (x 2)	-
Clip Stop with Adjustable Retention (x 2)	601H
Track stop (x 1)	287
Guide (x 1)	PD/WRAP
Round Flush Pull Set in Satin (x 1)	-

**** Replace by length of track for full short code

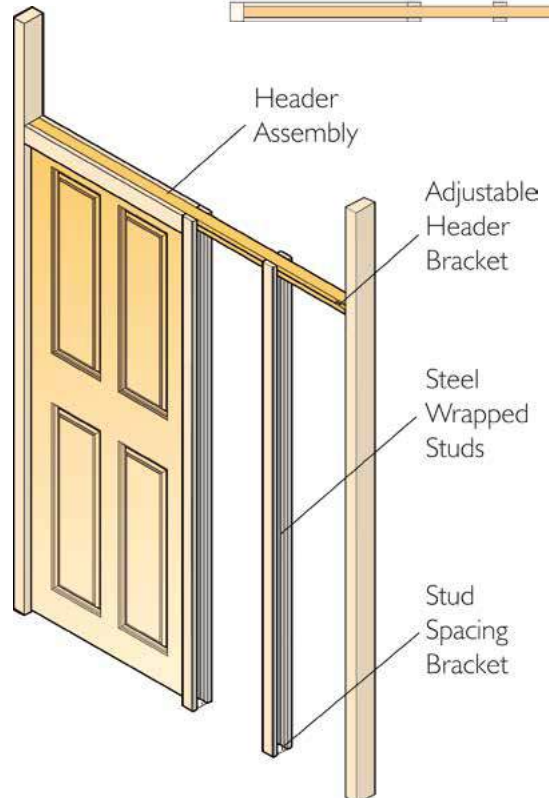
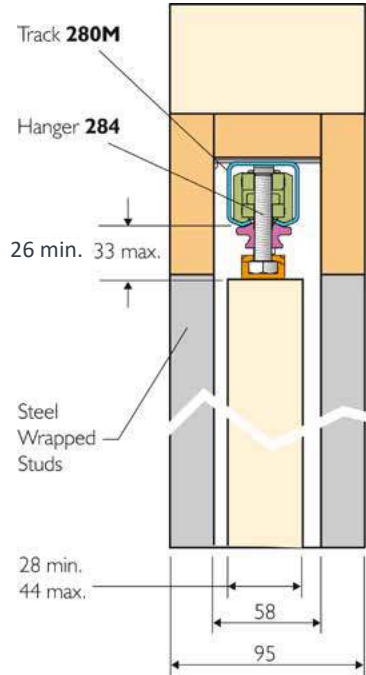
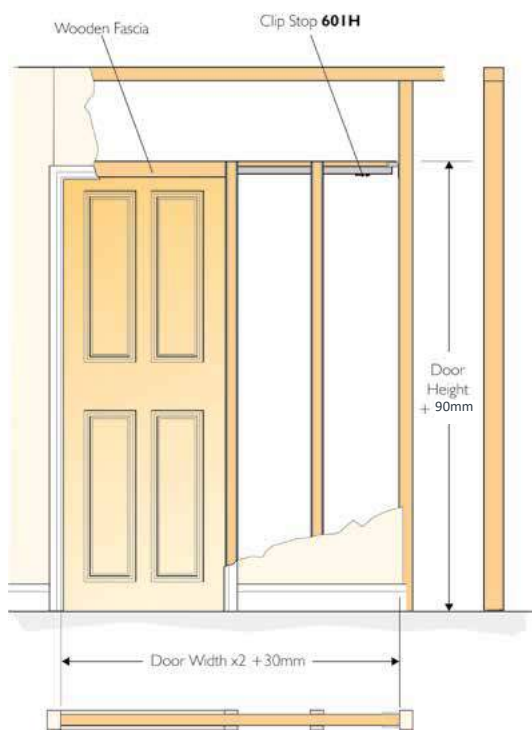

▶ Watch the Installation Video
pchenderson.com/pocket-door-installation

Opening Size Guide

Kit	Rough Opening Size	Cavity Thickness	Finished Wall Thickness
PDK3	1554mm (w) x 2071mm (h)	95mm	120mm
PDK4	1706mm (w) x 2071mm (h)	95mm	120mm
PDK5	1554mm (w) x 2130mm (h)	95mm	120mm
PDK6	1682mm (w) x 2130mm (h)	95mm	120mm
PDK7	1482mm (w) x 2130mm (h)	95mm	120mm
PDK10	1890mm (w) x 2405mm (h)	95mm	120mm

Accessories



Round Lockable Flush Pull Set (390/S) for 35 - 52mm thick doors, also available in chrome



Round Lockable Flush Pull Set with Indicator (571/S) for 40 - 45mm thick doors, also available in chrome

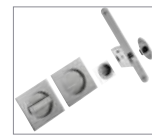

Square Lockable Flush Pull Set (60SQ/S) for 35 - 52mm thick doors, also available in chrome



Door Edge Pull (EDGE/S) for edge of door. Ideal for when using soft close system. Also available in chrome.



Fantom Magnetic Door Stop (FANTOMSL/S) other finishes also available.



Simultaneous Action Kit (SIM100) for two bi parting doors. Cannot be used with Pocket Door Soft Close

Prefer a different style of handle or flush pull to the one provided? View our full range of accessories on page 136

HUSKY GLASS

For sliding glass doors weighing up to 50kg and 75kg



Husky Glass is the ideal solution for lightweight glass applications such as office doors and small domestic glass partitions. The products versatility allows the kit to be face fixed or soffit fixed without compromising on the functionality of the system. The nature of these applications require quality aesthetic finishes, to meet this demand a purpose designed clip on fascia is also available.

Product Information

Product	Max. Door Width	Glass Thickness	Max. Door Weight
Husky Glass	1250mm	8, 10 or 12mm	50kg
	1250mm	8, 10 or 12mm	75kg

Product Specification

Component	Description	50kg System	75kg System
Track	Aluminium track in 1500, 1800, 2000, 2500, 3000, 4000, 5000 and 6000mm lengths	280A/****	280A/****
	Anodised aluminium track in 1500, 1800, 2000, 2500, 3000, 4000 and 6000mm lengths	280AN/****	280AN/****
Brackets	Face fixed bracket	281A	281A
	Jointing and end bracket	281AX	281AX
Glass Clamp Kit Consists of two hangers, two glass clamps, two 601H retaining stops and an adjustable guide	Glass clamp kit for 8mm glass	8/HY/50	8/HY/75
	Glass clamp kit for 10mm glass	10/HY/50	10/HY/75
	Glass clamp kit for 12mm glass	12/HY/50	12/HY/75
Floor Guide	Brushed stainless steel floor guide for 8mm, 10mm or 12mm glass	8-12/SN	8-12/SN
Fascia	Aluminium fascia in 2000, 3000 and 4000mm lengths	F136/****	F136/****
	End caps for fascia	F136/ECP	F136/ECP

**** Replace by length of track for full short code

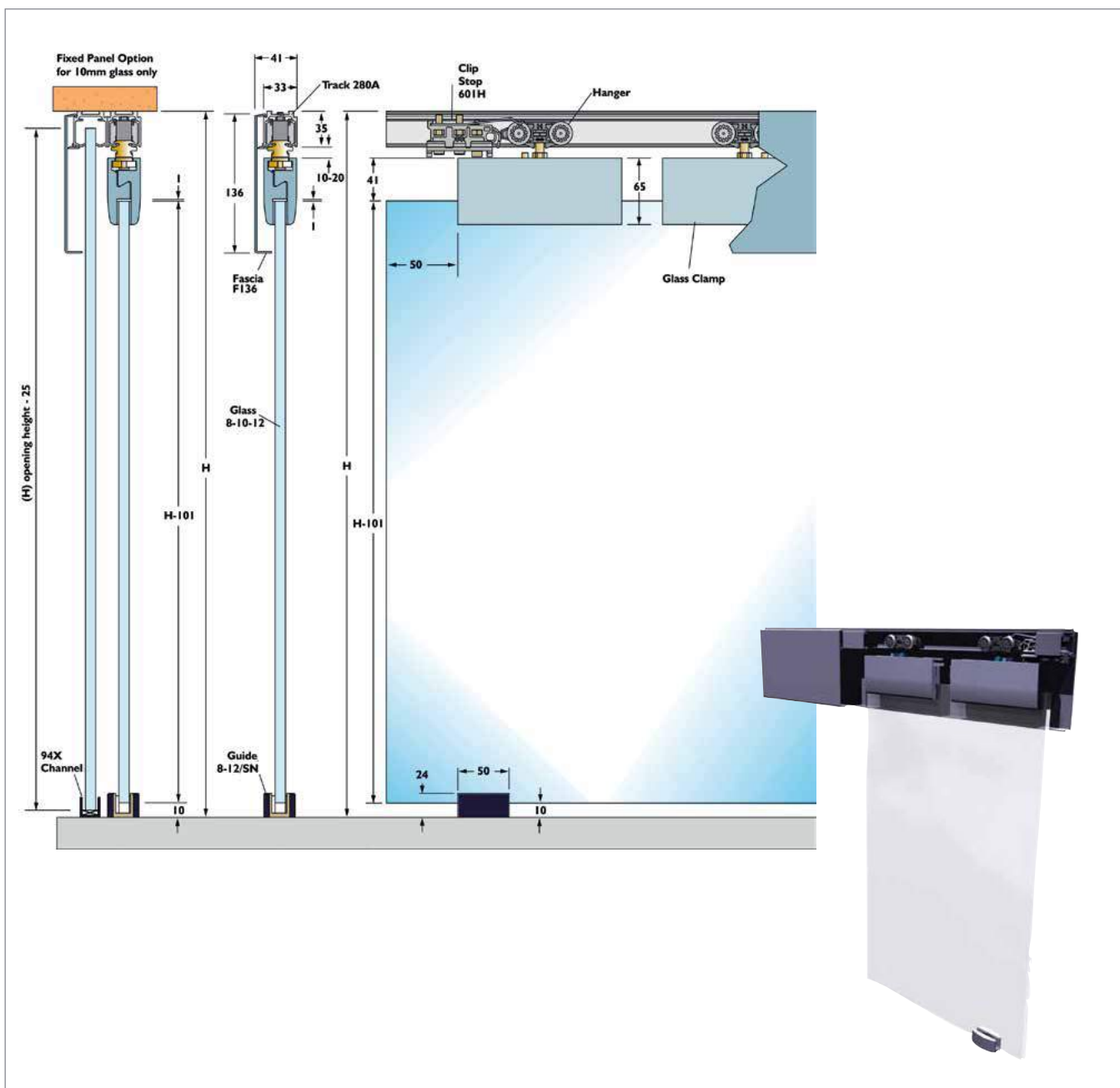

Hardware

Track



280A



280AN

Brackets



281A



281AX

Glass Clamp Kit



/HY/

Floor Guide



8-12/SN

Fascia



F136



F136/ECP

Accessories

View our full range of accessories on page 136

HUSKY TELESCOPIC

For sliding wooden telescopic doors weighing up to 80kg

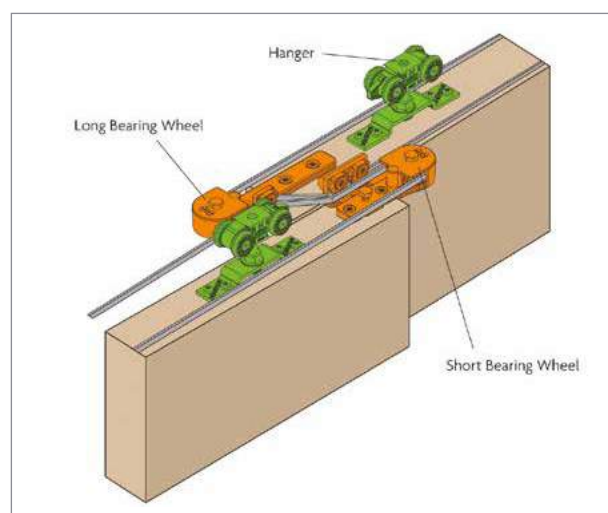

Perfect for wider openings, the Husky Telescopic range caters for multiple wooden doors weighing up to 80kg to become neatly stacked sliding partitions. The system has been designed to be discreet as it requires no guide channel meaning that a clear walkway can be created from room to room. All doors are linked together via a toothed belt and pulley system. By moving the lead door, all of the doors travel simultaneously with minimum friction and noise. The system is suitable for wood framed doors of flush, panelled or glazed construction and makes for an ideal room divider or partition door. For heavier doors weighing up to 120kg, we also have our Soltaire Telescopic system (see page 40).

Product Information

Kit Order Code	No. of Doors	Min. Door Width	Max. Door Width	Door Thickness Range	Max. Door Weight
TEL80/2	2	500mm	1200mm	32 - 47mm	80kg
TEL80/3	3	500mm	1200mm	32 - 47mm	80kg
TEL80/SIM	4 (2 +2)	500mm	1200mm	32 - 47mm	80kg

Kit Contents

Component	TEL80/2 Quantity	TEL80/3 Quantity	TEL80/SIM Quantity
Husky Hangers and Apron Plates	4	6	8
Short Bearing Wheel Assembly	1	2	2
Door Mounted Belt Fixing Bracket	1	2	4
Length of Toothed Belt	1	1	1
Following Door Guide	1	2	2
Fixed Base Floor Guide	1	1	2
Long Bearing Wheel Assembly	1	2	2
Wall Mounted Belt Fixing	1	1	2
Clip Stop	2	2	2

Track Specification - track must be purchased in addition to kit

Description	Short Code
Aluminium track in 1500, 1800, 2000, 2500, 3000, 4000, 5000 and 6000mm lengths	280A/****
Anodised aluminium track in 1500, 1800, 2000, 2500, 3000, 4000 and 6000mm lengths.	280AN/****

**** Replace by length of track for full short code

Accessories



Round Flush Pull Set
(**385/S**) satin, also available in chrome, black and polished brass



Aluminium Face Fixed Brackets x 5
(**2815A**)



Aluminium Face Fixed Brackets x 8
(**2818A**)



Soffit Fixed Fascia (**F134**) for aluminium track and doors up to 30mm thick



Fascia End Caps (**F134/ECP**) for F134 fascia



Face Fixed Fascia (**F140**) for aluminium track and doors up to 50mm thick, includes end caps

View our full range of accessories on page 136

SIROCCO

Self-closing sliding door system for wooden or metal doors weighing up to 80kg



The Sirocco system is a quiet, user friendly system with an integrated hydraulic self closing system which brings the door to a safe and gentle close. The system has been designed to give a quiet and smooth operation and features an adjustable closing speed feature. Common applications for this system include hospitals and disabled access points. The optional hold open unit also allows you to adjust the time before the self close engages meaning you can hold the door open for as long as required.

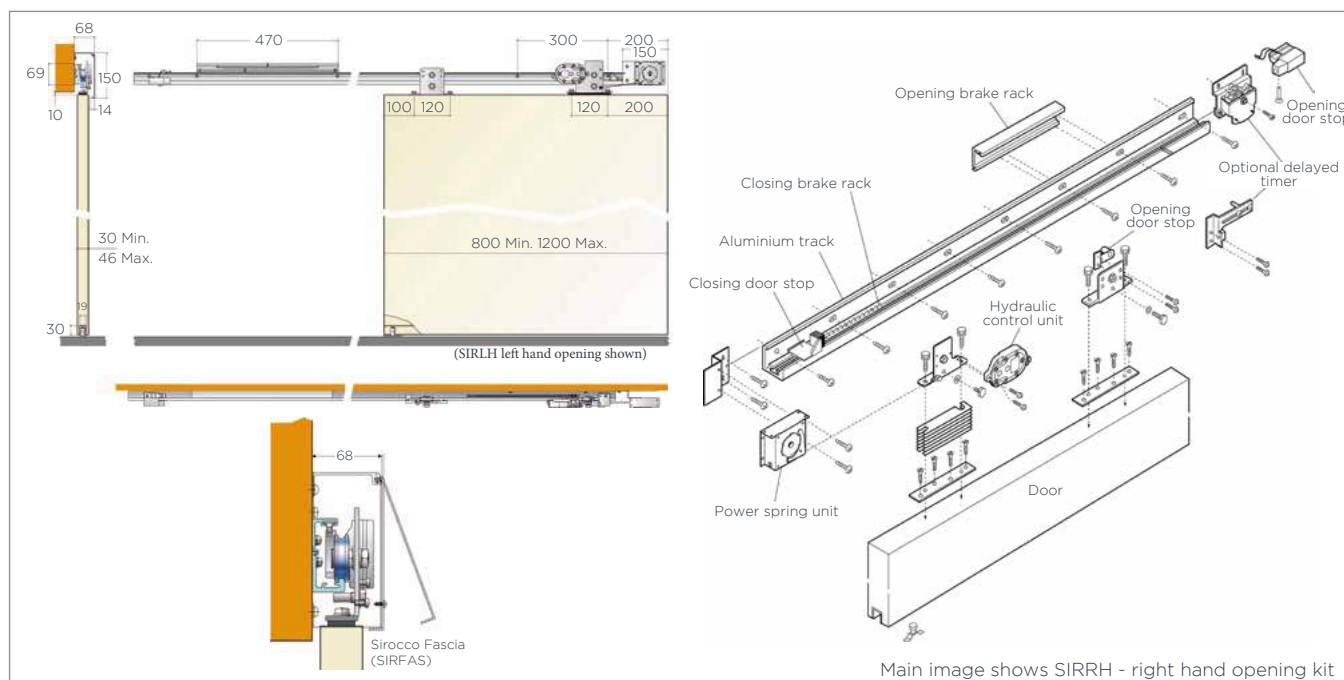

Product Information

Kit Order Code	Description	No. of Doors	Track Length	Max. Door Width	Door Thickness Range	Max. Door Weight
SIRRH	Right hand opening kit	1	2200mm	1200mm	30 - 46mm	80kg
SIRLH	Left hand opening kit	1	2200mm	1200mm	30 - 46mm	80kg

Accessories



Round Flush Pull Set (**385/S**) satin, also available in chrome, polished brass and black



Square Flush Pull Set (**53/S**) satin, also available in chrome and black



Oval Flush Pull (**144S**) satin, also available in black



Rectangle Flush Pull (**125/S**) satin, also available in chrome



Delayed Closing Timer Right Hand (**DELRH**)



Delayed Closing Timer Left Hand (**DELLH**)



Fascia (**SIRFAS**)

View our full range of accessories on page 136

RUSTIC 100



Watch the Installation Video
pchenderson.com/rustic-installation



Unique sliding door hardware with beautifully crafted barn style hangers, for doors weighing up to 100kg



NOW WITH
**SOFT
STOP**



Rustic 100 is ideal for barn conversions, period properties or simply for a unique feature in the home. Suitable for internal doors weighing up to 100kg, the system creates a traditional look for sliding wooden or metal doors with the exposed steel straps fastening down the front of the door. The system is available in a choice of finishes including; matt black, stainless steel or our new antique rust effect. Tracks are available in 2m or 3m lengths and a fittings kit can be purchased for when an extra door is required. Each kit comes complete with two oval flush pulls.

The system is also now available as a soft stop kit. The kit gently decelerates the door upon opening or closing and glides it into its final position - preventing unwanted slamming. The easy to install soft stop kit can be fitted to new or existing applications and can be installed with any finish of kit due to its discreet design.

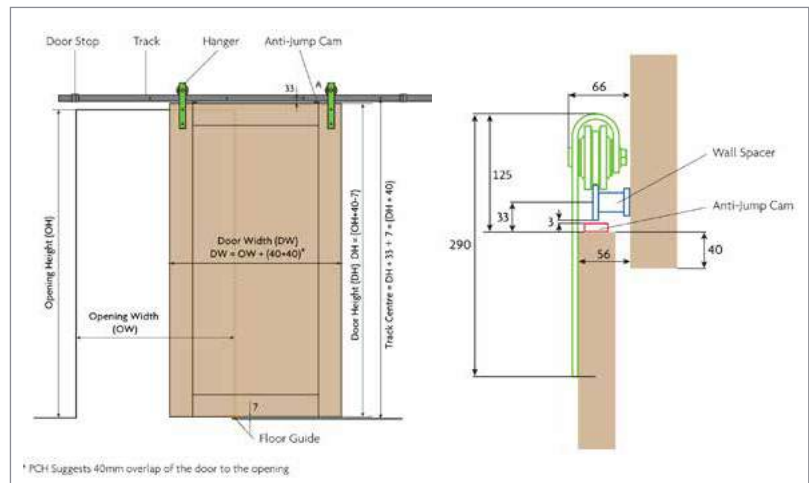

Product Information

Kit Order Code			Finish	Track Length	Door Width Range	Door Thickness <small>Installation method can be altered to suit thinner doors</small>	Max. Weight <small>(*80kg if soft close)</small>
Standard Kit	Single Soft Stop <small>(soft close OR open)</small>	Double Soft Stop <small>(soft close AND open)</small>					
R100/20	R80SOFT/20	R80SOFTD/20	Matt Black	2000mm	500 - 1000mm	36 - 46mm	100kg*
R100/30	R80SOFT/30	R80SOFTD/30	Matt Black	3000mm	500 - 1500mm	36 - 46mm	100kg*
R100SS/20	R80SSSOFT/20	R80SSSOFTD/20	Stainless Steel	2000mm	500 - 1000mm	36 - 46mm	100kg*
R100SS/30	R80SSSOFT/30	R80SSSOFTD/30	Stainless Steel	3000mm	500 - 1500mm	36 - 46mm	100kg*
R100RUST/20	R80RUSOFT/20	R80RUSOFTD/20	Antique Rust	2000mm	500 - 1000mm	36 - 46mm	100kg*
R100RUST/30	R80RUSOFT/30	R80RUSOFTD/30	Antique Rust	3000mm	500 - 1500mm	36 - 46mm	100kg*
R100			Matt Black	Fittings kit for when an additional door is required			
R100SS			Stainless Steel	Fittings kit for when an additional door is required			
R100RUST			Antique Rust	Fittings kit for when an additional door is required			

Kit Contents

Component

Hangers (x 2)	
Door Stops (x 2)	
Floor Guide (x 1)	
"Flat" Track (x 1)	
Track Wall Spacers (x 5 for 2m, x 7 for 3m)	
Anti-Jump Cam (x 2)	
Oval Flush Pulls (x 2)	(144B or 144S)

Accessories



Rustic Soft Stop Kit
(**R80SOFT**)



1 Door Fittings Kit in Black
(**R100**)



1 Door Fittings Kit in Stainless Steel
(**R100SS**)



1 Door Fittings Kit in Antique Rust
(**R100RUST**)

View our full range of accessories on page 136

RUSTIC TOP MOUNT

Contemporary sliding barn door hardware with top mounted hangers for doors weighing up to 100kg



NOW WITH
SOFT
STOP



New to the range, our Rustic Top Mount offers a stylish, contemporary twist on our classic Rustic 100 system - with its hangers being mounted to the top of the door. Ideal for barn conversions, period properties or simply for a unique feature in the home, the system caters for interior wooden doors weighing up to 100kg and is available in 2000mm and 3000mm track lengths. The system works with nylon rollers and a flat bar track to ensure quiet and smooth operation. The kit is available in matt black or stainless steel and comes complete with two oval flush pulls. A fittings kit is available for double door specifications.

The system is also now available as a soft stop kit. The kit gently decelerates the door upon opening or closing and glides it into its final position, preventing unwanted slamming. The easy to install soft stop kit can be fitted to new or existing applications and can be installed with any finish of kit due to its discreet design.

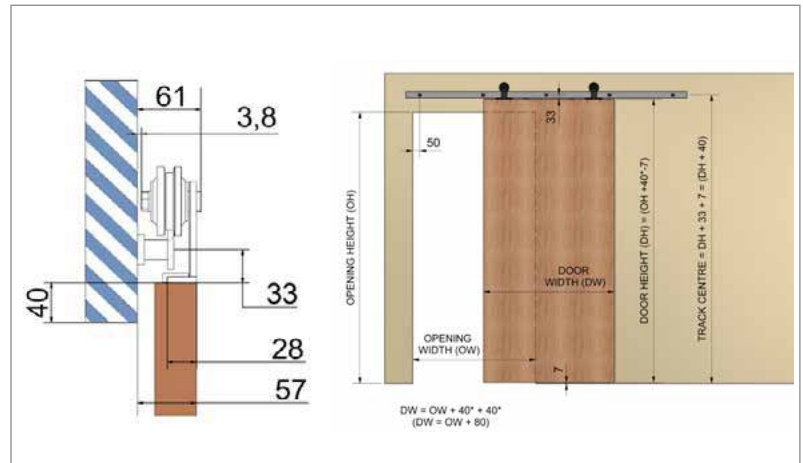

Product Information

Kit Order Code			Finish	Track Length	Door Width Range	Door Thickness	Max. Weight (*80kg if soft close)
Standard Kit	Single Soft Stop (soft close OR open)	Double Soft Stop (soft close AND open)					
RTM/20	RTMSOFT/20	RTMSOFTD/20	Matt Black	2000mm	500 - 1000mm	35 - 50mm	100kg*
RTM/30	RTMSOFT/30	RTMSOFTD/30	Matt Black	3000mm	500 - 1500mm	35 - 50mm	100kg*
RTMSS/20	RTMSSSOFT/20	RTMSSSOFTD/20	Stainless Steel	2000mm	500 - 1000mm	35 - 50mm	100kg*
RTMSS/30	RTMSSSOFT/30	RTMSSSOFTD/30	Stainless Steel	3000mm	500 - 1500mm	35 - 50mm	100kg*
RTM			Matt Black	Fittings kit for when an additional door is required			
RTMSS			Stainless Steel	Fittings kit for when an additional door is required			

Kit Contents

Component

Hangers (x 2)	
Door Stops (x 2)	
Floor Guide (x 1)	
"Flat" Track (x 1)	
Track Wall Spacers (x 5 for 2m, x 7 for 3m)	
Anti-Jump Cam (x 2)	
Oval Flush Pulls (x 2)	(144B or 144S)

Accessories



Rustic Soft Stop Kit
(R80SOFT)



1 Door Fittings Kit in Black (RTM)



1 Door Fittings Kit in Stainless Steel (RTMSS)

View our full range of accessories on page 136

MARATHON



Watch the Installation Video
pchenderson.com/marathon-installation



For sliding wooden and metal doors weighing up to 55kg and 90kg



When it comes to residential or commercial sliding doors and partitions, Marathon sliding door hardware is extremely reliable. Designed for wooden, wood framed and composite doors and featuring a one piece ball cage design, Marathon offers a smooth running system which can easily be adjusted. A self closing door kit can also be added to further complement the system (see accessories).

Available as the Marathon 55 for doors up to 55kg and Marathon 90 for doors up to 90kg, the system can handle door thickness's of between 32 - 50mm and door widths of up to 2500mm. For bi-parting doors - two kits should be purchased.

Please note that the track is unable to be cut down on this system.

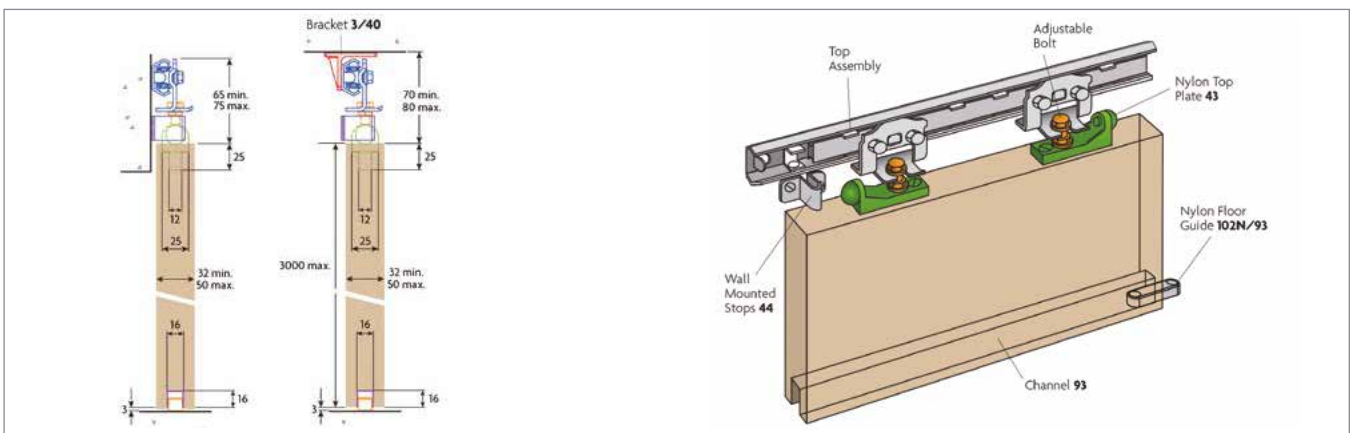

Product Information

Product	Kit Order Code	No. of Doors	Track Length	Door Width Range	Door Thickness Range	Max. Door Weight
Marathon 55	J2	1	1219mm	400 - 750mm	32 - 50mm	55kg
	J3	1	1473mm	750 - 900mm	32 - 50mm	55kg
	J4	1	1702mm	900 - 1050mm	32 - 50mm	55kg
	J5	1	1981mm	1050 - 1200mm	32 - 50mm	55kg
	J6	1	2438mm	1200 - 1500mm	32 - 50mm	55kg
Marathon 90	S2	1	1219mm	400 - 750mm	32 - 50mm	90kg
	S3	1	1473mm	750 - 900mm	32 - 50mm	90kg
	S4	1	1702mm	900 - 1050mm	32 - 50mm	90kg
	S5	1	1981mm	1050 - 1200mm	32 - 50mm	90kg
	S6	1	2438mm	1200 - 1500mm	32 - 50mm	90kg
	S7	1	3048mm	1500 - 1800mm	32 - 50mm	90kg
	S8	1	3226mm	1800 - 2000mm	32 - 50mm	90kg
	S9	1	4420mm	2000 - 2500mm	32 - 50mm	90kg

Kit Contents

Component	Short Code
Aluminium Track (x 1)	-
Bottom Channel (x 1)	93S/****
Top Assembly (x 1)	-
Nylon Top Plates (x 2)	43
Wall Mounted Stops (x 2)	44
Nylon Floor Guide (x 1*)	102N/93

*2 nylon floor guides are supplied in the J6, S6, S7, S8 & S9

Accessories



Round Flush Pull Set (**385/S**) satin, other finishes available



Oval Flush Pull (**144S**) satin, also available in black



Rectangle Flush Pull (**125/S**) also available in chrome



Self-Closing Door Kit (**SCK1**)



Galvanised Steel Fascia (**40P/1854**)



Fascia End Cap (**EC40P**)

View our full range of accessories on page 136

MARATHON FIRE RATED

For certified FD30 sliding fire doors weighing up to 90kg



Marathon Fire Rated is a system developed as part of a 30 minute sliding fire door assembly to BS476: Part 22: 1987 and should be installed on the non-fire risk side of an aperture. The hardware should be fitted with a certified FD30 fire door.

With two variations available, you can choose between our FDK1 self-closing or FDK2 non self-closing system. Please consult your Building Inspector prior to purchase to determine if your application requires a self closer.

Assessment report WFRC No. C116602 confirms that a sliding fire door assembly, fitted in accordance with these instructions, will offer 30 minutes of fire protection in accordance with BS 476: Part 22: 1987, (ref: report Warres No. 40991). To be used for fire control only, cannot be used for smoke control.

Note: A Marathon 90 (S3, S4, S5 or S6) sliding door hardware kit must be used in conjunction with this system See specification information below.

Assessment report WFRC No. C116602 can be viewed on our website at www.pchenderson.com.

Fire Door Kit Information

Kit Order Code	Description	Fire Rating	Max. Door Width	Max. Door Height	Door Thickness	Max. Door Weight
FDK1	Self Closing	FD30	1500mm	3000mm	44 - 50mm	90kg
FDK2	Non Self Closing	FD30	1500mm	3000mm	44 - 50mm	90kg

Sliding Door Kit Specification - must be specified in addition to fire door kit

Product	Kit Order Code	No. of Doors	Track Length	Door Width Range	Max. Door Weight
Marathon 90	S3	1	1473mm	750 - 900mm	90kg
	S4	1	1702mm	900 - 1050mm	90kg
	S5	1	1981mm	1050 - 1200mm	90kg
	S6	1	2438mm	1200 - 1500mm	90kg

Fire Door Kit Contents

"Z" section
Apron assembly
Door binder - front edge
Door binder - back edge
Binder - receiving plate
Guide
Cable anchor plate (self close only)
Pulley assembly (self close only)
Adjustment stem and cable sub assembly (self close only)
0.5kg main weight (self close only)
Coined weights (self close only)
Clamp cleat (self close only)



HUSKY SLIDING

For sliding wooden or metal doors weighing up to 50kg and 100kg



Versatile and quiet, the Husky sliding door hardware system is ideal for creating wardrobe doors and room dividing doors with one or more wooden, wood framed, composite or metal doors. The Husky 50 supports doors of up to 50kg, whilst the Husky 100 supports slightly heavier doors up to 100kg. Optional fittings kits allow additional doors to be fitted to a maximum door width of 1250mm. The product comes available as standard with a choice of aluminium or steel track - an anodised aluminium track can be provided upon request.

This product is also now available with an integrated soft stop (see page 33).

Looking for the soft stop version?
See page 33

Product Information

Product	Kit Order Code (Steel Track)	Kit Order Code (Aluminium Track*)	No. of Doors	Track Length	Max. Door Width	Door Thickness Range	Max. Door Weight
Husky 50	H50/15	H50/15A	1	1500mm	800mm	20 - 50mm	50kg
	H50/18	H50/18A	1	1800mm	950mm	20 - 50mm	50kg
	H50/20	H50/20A	1	2000mm	1050mm	20 - 50mm	50kg
	H50/24	H50/24A	1	2400mm	1250mm	20 - 50mm	50kg
	H50N		Fittings kit for when an additional door is required				
Husky 100	H100/15	H100/15A	1	1500mm	800mm	20 - 50mm	100kg
	H100/18	H100/18A	1	1800mm	950mm	20 - 50mm	100kg
	H100/20	H100/20A	1	2000mm	1050mm	20 - 50mm	100kg
	H100/24	H100/24A	1	2400mm	1250mm	20 - 50mm	100kg
	H100		Fittings kit for when an additional door is required				

*An anodised aluminium track (280AN/****) is also available upon request

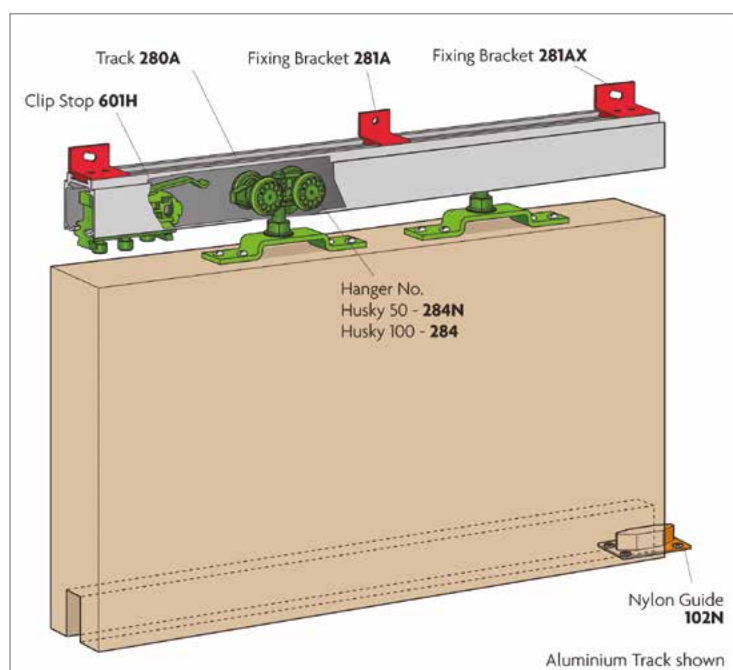

Kit Contents

Component	Short Code (Aluminium Track)	Short Code (Steel Track)
Track (x 1)	280A/****	280/****
Face Fixed Jointing Brackets (x2)	281AX	-
Faced Fixed Brackets	281A	281
Nylon Bodied Hangers* (x 2)	284N (Husky 50) or 284 (Husky 100)	284N (Husky 50) or 284 (Husky 100)
Nylon Guide (x 1)	102N	102N
Clip Stop (x 1)	601H	601H
Track Stop (x 1)	287	287

****Replace by length of track for full short code

*For metal doors, 285N (Husky 50) and 285 (Husky 100) hangers must be specified.

Components can be specified separately for bespoke projects, contact P C Henderson for details.



Watch the Installation Video
pchenderson.com/husky-sliding-installation



ALUMINIUM TRACK

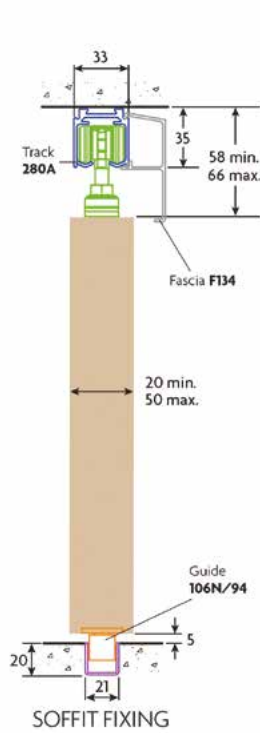
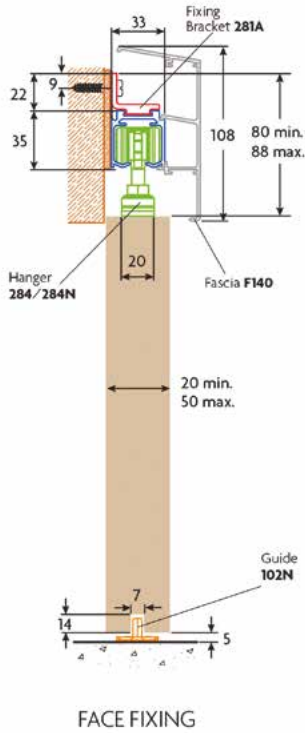

STEEL TRACK

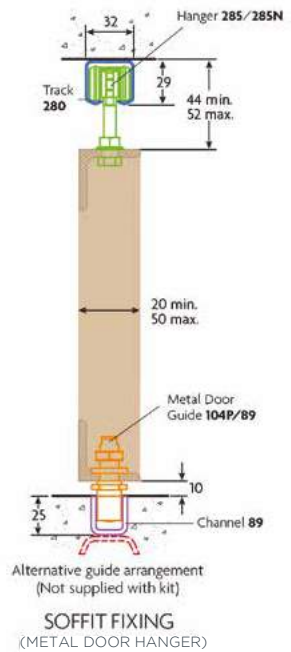
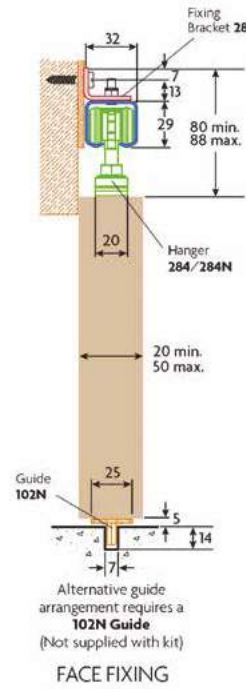

Accessories

SIM Kit and Self Door Closer



Simultaneous Action Kit (SIM100) only for use with Husky 100



Easyclose Self Door Closer (SC100) for doors weighing up to 100kg

Fittings Kits



1 Door Fittings Kit (H50N) for Husky 50



1 Door Fittings Kit (H100) for Husky 100

Fascia



Aluminium Soffit Fixed Fascia (F134/****) for doors up to 50mm thick



Fascia End Cap Pack (F134/ECP) for F134 fascia

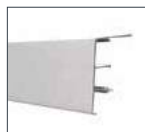

Aluminium Face Fixed Fascia (F140/****) for doors up to 50mm thick, includes end caps

Alternative Guiding System



Aluminium Guide Channel (94X/****)



Roller Guide for Wooden Doors (106N/94)

Stops



Magnetic Door Stop for Sliding Doors (FANTOMSL/S) PCH recommend that a different guide is used if installing this accessory

Brackets



Face Fixed Brackets - pack of 5 or 8 (2815 or 2818) for steel track



Face Fixed Brackets - pack of 5 or 8 (2815A or 2818A) for aluminium track

Flush Pulls



Round Flush Pull Set (385/S) satin, also available in chrome, polished brass and black

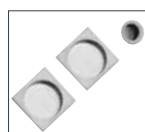

Square Flush Pull Set (53/S) satin, also available in chrome and black



Oval Flush Pull (144S) satin, also available in black



Rectangle Flush Pull (125/S) satin, also available in chrome

View our full range of accessories on page 136

****Replace by length of track for full short code

HUSKY LOW HEADROOM

For wooden sliding doors weighing up to 100kg with all parts concealed



Versatile and quiet, with the added benefit of all door hardware being concealed, the Husky Low Headroom Kit is ideal for creating wardrobe doors and room dividing doors with one or more wooden, wood framed or composite doors. Catering for doors weighing up to 100kg, the kit is designed to reduce the clearance between the track and top of the door to 2mm - making the hardware barely visible. This system can be face fixed or soffit fixed. Please note, the track must be specified in addition to the kit (see tables below).

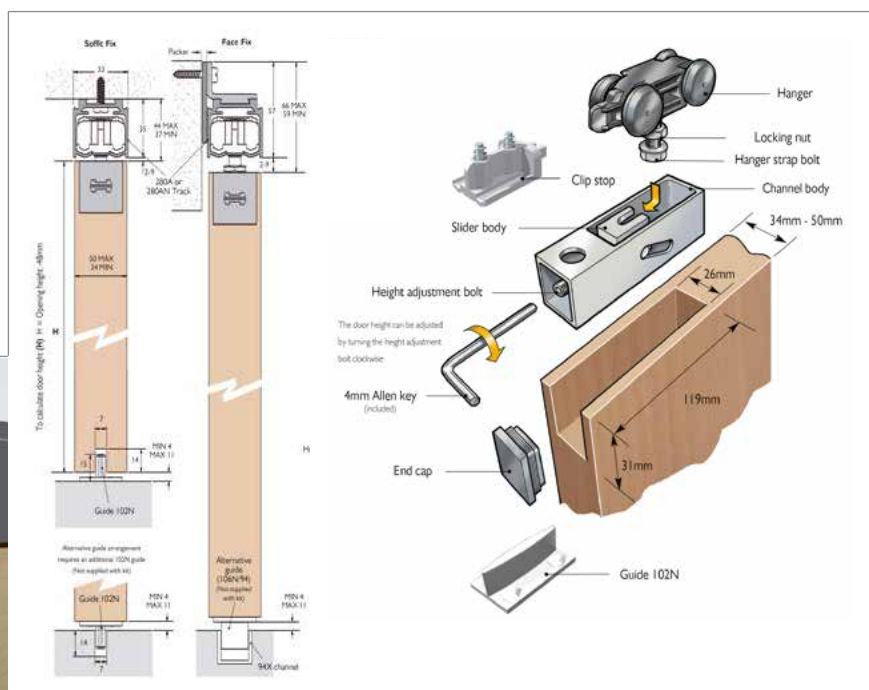
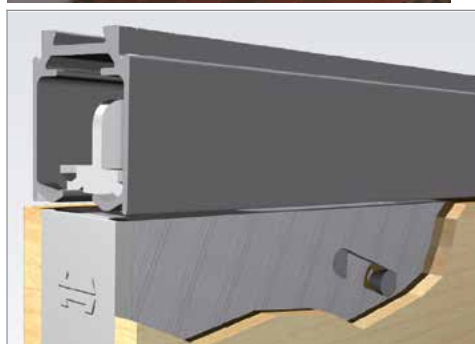

Product Information

Kit Short Code	Max. Door Width	Door Thickness Range	Max. Door Weight
LH100	1250mm	34 - 50mm	100kg

Track and Bracket Specification - must be purchased in addition to kit

Component	Short Code	Description
Track	280A/****	Aluminium track in 1500, 1800, 2000, 2500, 3000, 4000, 5000 & 6000mm
	280AN/****	Anodised aluminium track in 1500, 1800, 2000, 2500, 3000, 4000 & 6000mm
	280/****	Steel track in 1200, 1500, 1800, 2000, 2400, 2500, 3000, 4000, 5000 & 6000mm
Brackets 1 every 275mm	2815A or 2818A	Aluminium brackets for face fixed installation (pack of 5 or 8, use corresponding short code)
	2815 or 2818	Steel brackets for face fixed installation (pack of 5 or 8, use corresponding short code)
End Brackets 1 at each end of track (alumin. only)	281AX	Aluminium end and jointing brackets for face fixed installation

Kit Contents

Component	Short Code
Low Headroom Units (x 2)	-
End Caps (x 2)	-
Low Headroom Clip Stops (x 2)	286LH
Low Headroom Hangers (x 2)	283LH
Guide (x 1)	102N
Allen Key (x 1)	-
Screw Pack (x 1)	-

Accessories



Round Flush Pull (**385/S**)
satin, other finishes available



Aluminium Guide Channel (**94X/******)



Roller Guide for Wooden Doors (**106N/94**)



Floor Stop (**103**)

****Replace by length of track for full short code

View our full range of accessories on page 136

HUSKY SOFT STOP

For wooden and metal sliding doors weighing up to 100kg with built-in soft close and opening mechanism

NEW



Husky Soft Stop is a new product from P C Henderson which caters for sliding wooden and metal doors weighing up to 100kg. This superior product comes with the added benefit of a built-in dual soft close **and** opening mechanism which gently decelerates the door and pulls it into its final position. The result is an extremely sophisticated and quiet system which boasts anti-slamming properties and enhanced product longevity.

The dual soft stop is pre-assembled and concealed within the track to provide ease of installation and a minimalistic finish. To ensure optimum performance the product is available in five kit variants, depending on the door weight of your application, and can be combined with two choices of track. The system can be soffit or face fixed depending on the application and for bi-parting doors, two kits can be used.

Note: Kit SOFTH100 (for doors weighing between 80 - 100kg) has a single soft stop only.



Watch the Installation Video

pchenderson.com/husky-soft-stop-installation



Product Information

Short Code	No. of Doors	Min. Door Width	Max. Door Width	Door Thickness Range	Door Weight Range
SOFTH20	1	600mm	1150mm*	20 - 50mm	10 - 20kg
SOFTH40	1	600mm	1150mm*	20 - 50mm	20 - 40kg
SOFTH60	1	600mm	1150mm*	20 - 50mm	40 - 60kg
SOFTH80	1	600mm	1150mm*	20 - 50mm	60 - 80kg
SOFTH100**	1	600mm	1150mm*	20 - 50mm	80 - 100kg

*For doors between 1150mm and 3000mm wide a 284SOFT hanger should be purchased in addition to the kit. Please contact a member of our technical sales department for installation advice.

**Single soft close only

Track and Bracket Specification - must be purchased in addition to kit

Component	Short Code	Description
Track	280A/****	Aluminium track in 1500, 1800, 2000, 2500, 3000, 4000, 5000 & 6000mm
	280AN/****	Anodised aluminium track in 1500, 1800, 2000, 2500, 3000, 4000 & 6000mm
Brackets - 1 every 275mm	2815A or 2818A	Aluminium brackets for face fixed installation (pack of 5 or 8, use corresponding short code)
Jointing Brackets 1 at each end of track (alumin. only)	281AX	Aluminium jointing brackets for face fixed installation



Kit Contents

Component

Hangers
Dampers
Triggers
Apron Plates
Floor Guide
Clip Stop (SOFTH100 only)
All Required Fixings

Accessories



Round Flush Pull Set (385/S) satin, other finishes also available



Square Flush Pull Set (53/S) satin, also available in chrome



Oval Flush Pull (144S) satin, also available in black



Wide Door Hanger (284SOFT) for doors over 1150mm wide. Please consult PCH technical team for installation guidance.

View our full range of accessories on page 136

POCKET DOOR PRO

Professional sliding door solution that works with cavity walls for doors weighing up to 120kg

NEW



Pocket Door Pro is a professional hardware solution that allows doors to effortlessly slide into a cavity wall. Designed with a high quality, aluminium cavity frame, the system is extremely robust - making it ideal for homes, educational buildings, hospitals, hotels and office blocks. The system is also ideal for disability access areas as well as rooms where space is limited such as bathrooms and ensuites.

The aluminium cavity frame comes with push together parts for easy and rapid installation. The system is available with an optional soft stop which catches the door in its final moments of travel and gently brings it into position - preventing slamming.

The system is available in seven different kit sizes (which can be cut to size) and for finished wall thickness's of 120mm and 125mm.

Available accessories include a timber liner kit (for a professional finish), self close system and simultaneous action kit. The system is also available for single fire rated doors (page 36), bi-parting fire doors (page 38) and automated doors (page 114). For bi-parting doors, two kits should be specified. For non soft closing bi-parting doors, you will also need to purchase two HH4/AN track stops (see step 3).

STEP 1: FOR SINGLE DOORS AND BI-PARTING DOORS

Choose Your Kit (for bi-parting doors, two kits should be specified)

Short Code		Max. Door Width	Max. Door Height	Door Thickness	Max. Door Weight		Finished Wall Thickness
Standard	With Soft Stop				Standard	With Soft Close	
PDKPRO1/**	N/A	610mm	1981mm	35 - 45mm	120kg	80kg	120mm or 125mm
PDKPRO2/**	PROSOFT2/**	686mm	1981mm	35 - 45mm	120kg	80kg	120mm or 125mm
PDKPRO3/**	PROSOFT3/**	762mm	1981mm	35 - 45mm	120kg	80kg	120mm or 125mm
PDKPRO4/**	PROSOFT4/**	838mm	1981mm	35 - 45mm	120kg	80kg	120mm or 125mm
PDKPRO6/**	PROSOFT6/**	826mm	2040mm	35 - 45mm	120kg	80kg	120mm or 125mm
PDKPRO7/**	PROSOFT7/**	726mm	2040mm	35 - 45mm	120kg	80kg	120mm or 125mm
PDKPRO10/**	PROSOFT10/**	930mm	2315mm	35 - 45mm	120kg	80kg	120mm or 125mm

*** For full short code please replace with required finished wall thickness size - 120 or 125 (mm)

STEP 2: FOR SINGLE DOORS

Choose Your Liner Kit

Kit Short Code	Functionality	Max. Door Thickness	Finished Wall Thickness
LK/**	Non self closing liner kit	45mm	120mm or 125mm
SCLK/**	Liner kit complete with self close system (Please specify with a PROSOFT kit)	45mm	120mm or 125mm

*** For full short code please replace with required finished wall thickness size - 120 or 125 (mm)

OR

STEP 2a: FOR BI-PARTING DOORS

Choose Your Liner Kit

Kit Short Code	Max. Door Thickness	Finished Wall Thickness
BILK/**	45mm	120mm or 125mm

*** For full short code please replace with required finished wall thickness size - 120 or 125 (mm)

NEW
Bi-parting liner kits, self close and SIM kits available Summer 2020

STEP 2b: FOR BI-PARTING DOOR

Choose Your Optional Extras



Self Closing Kit (**BISELF**) (To be used with PROSOFT)

If Using Without a Simultaneous Action Kit
Please purchase x2 BISELF kits

Is Using With a Simultaneous Action Kit
For doors 0-50kg: Please purchase x1 BISELF kit
For doors 50 - 80kg: Please purchase x2 BISELF kits.



Simultaneous Action Kit (**SIM100**) open/close one door and the other will open/close simultaneously



Watch the Installation Video
pchenderson.com/pocket-door-pro-installation

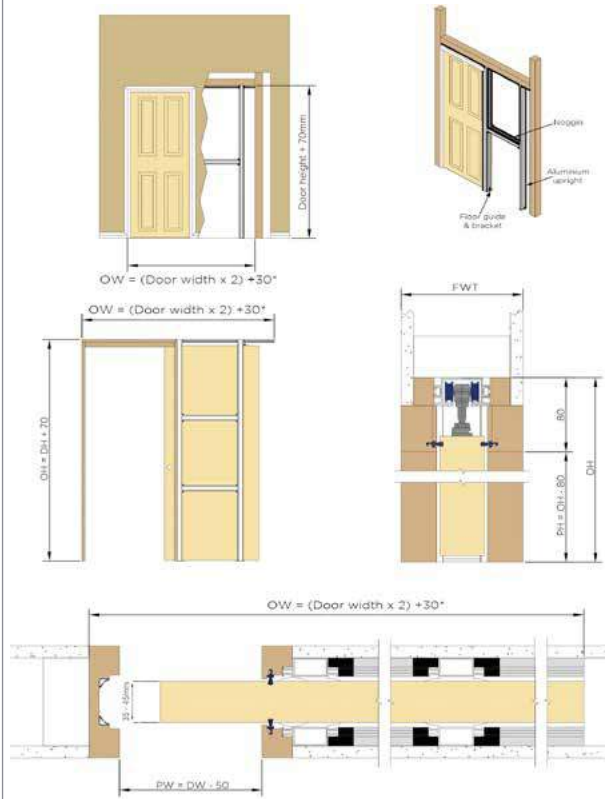

Key	
OW	Overall width
OH	Overall height
DH	Door height
DW	Door width
PH	Opening height
PW	Opening width
FWT	Finished wall thickness

Kit Contents	
Component	
Aluminium Header Track	(x1)
Aluminium Upright	(x4)
Hangers	(x2)
Floor Guide	(x1)
Fixing Plate	(x4)
Header Fixing Bracket	(x8)
Track Stop	(x1)
Noggin c/w Fixing Block	(x2) (x4 for PDKPRO10)
Floor Bracket	(x2) (x4 for PDKPRO10)
Screws	
Tie Back c/w Fixing Block	(x4) (PDKPRO10 only)

For Bi-Parting Doors
 PW = (2 x DW) - 50

* If using a self close system, this dimension changes to 62mm.

Opening Size Guide for Single Doors

Kit	Max. Passage Size (W x H)	Overall Dimensions (W x H)	Cavity Thickness	Finished Wall Thickness (FWT)
PDKPRO1/**	560mm x 1971mm	1250mm x 2051mm	95mm or 100mm	120mm or 125mm
PDKPRO2/**	636mm x 1971mm	1402mm x 2051mm	95mm or 100mm	120mm or 125mm
PDKPRO3/**	712mm x 1971mm	1554mm x 2051mm	95mm or 100mm	120mm or 125mm
PDKPRO4/**	788mm x 1971mm	1706mm x 2051mm	95mm or 100mm	120mm or 125mm
PDKPRO6/**	776mm x 2030mm	1682mm x 2110mm	95mm or 100mm	120mm or 125mm
PDKPRO7/**	676mm x 2030mm	1482mm x 2110mm	95mm or 100mm	120mm or 125mm
PDKPRO10/**	880mm x 2305mm	1890mm x 2385mm	95mm or 100mm	120mm or 125mm

*** For full short code please replace with required finished wall thickness size - 120 or 125 (mm)

Finished Wall Thickness Calculation

120mm Finished Wall Thickness

95mm cavity + 12.5mm plasterboard either side = 120mm finished wall thickness

125mm Finished Wall Thickness

100mm cavity + 12.5mm plasterboard either side = 125mm finished wall thickness

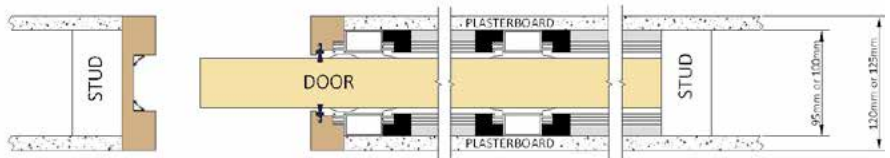

STEP 3: FOR SINGLE AND BI-PARTING DOORS
 Choose Your Flush Pull or Lock Set (and stop if required)

Flush Pulls Sets

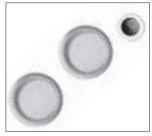

Round Flush Pull Set (385/S) satin, also available in chrome, polished brass and black



Round Flush Pull Set with Door Edge Pull (385EDGE/S) satin, also available in chrome and black

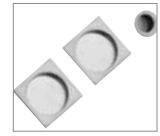

Square Flush Pull Set (53/S) satin, also available in chrome and black

Lock Sets



Round Lockable Flush Pull Set (390/S) satin, also available in chrome



Round Lockable Flush Pull Set with Indicator (571/S) satin, also available in chrome



Square Lockable Flush Pull Set (60SQ/S) satin, also available in chrome

Track Stop



Track Stop (HH4/AN) two required if installing non soft closing bi-parting doors

View our full range of accessories on page 136

POCKET DOOR PRO FIRE RATED Single Door

Fire rated pocket door hardware certified to FD30 and FD60 standards

NEW



Pocket Door Pro Fire Rated for Single Doors contains all the benefits of our Pocket Door Pro kit as well as being certified to FD30 and FD60 standards. The kit comes complete with intumescent seals and is made out of FDC Finger Jointed Laminated Redwood. The process of finger jointing, combined with a laminated finish, means that the wood is knot and defect free and delivers significantly better product reliability over time.

The system is available in seven different kit sizes, for FD30 or FD60 installations and self closing or non self closing options. Please consult your building inspector prior to purchase to determine if your application requires a self closer.

The kit should be specified in two parts (see below tables) to combine the certified fire rated liner kit with the relevant Pocket Door Pro hardware kit.

Certification: The FD30 system has been independently tested and certified to both BS 476:Part22:1987 and BS EN 1634-1:2014+A1:2018 standards. The FD60 system has been tested to BS 476:Part22:1987 standards. Systems should be fitted with a solid core FD30 or FD60 timber based fire door.

STEP 1: Choose Your Fire Rated Liner Kit

Kit Short Code	Fire Rating	Functionality	Max. Door Thickness	Finished Wall Thickness	
				Before Double Boarding	After Double Boarding
LKFD30/**	FD30 (30 minutes)	Standard liner kit	45mm	120mm or 125mm	145mm or 150mm
SCLKFD30/**		Liner kit complete with self close system (Please specify with a PROSOFT kit)			
LKFD60/125	FD60 (60 minutes)	Standard liner kit	54mm	125mm	150mm
SCLKFD60/125		Liner kit complete with self close system (Please specify with a PROSOFT kit)			

*** For full short code please replace with required finished wall thickness size **before** double boarding - 120 or 125 (mm). See calculation on adjacent page.

STEP 2: Choose Your Pocket Door Pro Kit - Must be specified in addition to a fire rated liner kit

Short Code		Max. Door Width	Max. Door Height	Max. Door Weight		Finished Wall Thickness	
Standard	With Soft Stop			Standard	With Soft Close	Before Double Boarding	After Double Boarding
PDKPRO1/**	N/A	610mm	1981mm	120kg	80kg	120mm or 125mm	145mm or 150mm
PDKPRO2/**	PROSOFT2/**	686mm	1981mm				
PDKPRO3/**	PROSOFT3/**	762mm	1981mm				
PDKPRO4/**	PROSOFT4/**	838mm	1981mm				
PDKPRO6/**	PROSOFT6/**	826mm	2040mm				
PDKPRO7/**	PROSOFT7/**	726mm	2040mm				
PDKPRO10/**	PROSOFT10/**	930mm	2315mm				

*** For full short code please replace with required finished wall thickness size **before** double boarding - 120 or 125 (mm). See calculation on adjacent page.

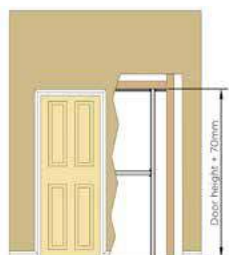

Fire Rated Liner Kit
 Complete with intumescent seals

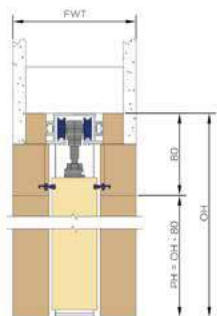
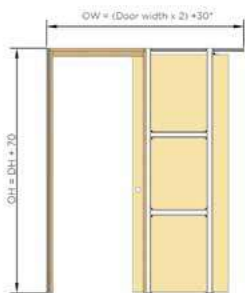

Key	
OW	Overall width
OH	Overall height
DH	Door height
DW	Door width
PH	Opening height
PW	Opening width
FWT	Finished wall thickness

* If using a self close system, this dimension changes to 62mm

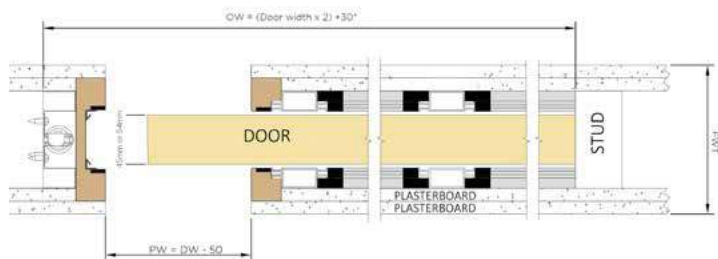

Fire Rated Finished Wall Thickness Calculation

To ensure compliance with BS 476 Part 22 and BS EN 1634 - 12.5mm of extra fire rated board should be applied to either side when using a fire rated liner kit. This brings the finished wall thickness to 145mm or 150mm. Note FD60 is only available for a 150mm finished wall thickness.

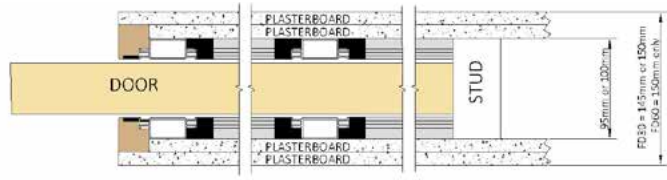
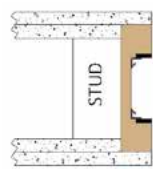

145mm Finished Wall Thickness Calculation

95mm cavity + 12.5mm fire rated board either side = 120mm
 + an additional 12.5mm fire rated board either side = 145mm

150mm Finished Wall Thickness Calculation

100mm cavity + 12.5mm fire rated board either side = 125mm
 + an additional 12.5mm fire rated board either side = 150mm

Opening Size Guide for Single Doors

Kit	Max. Passage Size (W x H)	Overall Dimensions (W x H)	Cavity Thickness	Finished Wall Thickness	
				Before Double Boarding	After Double Boarding
PDKPRO1/**	560mm x 1971mm	1250mm x 2051mm	95mm or 100mm	120mm or 125mm	145mm or 150mm
PDKPRO2/**	636mm x 1971mm	1402mm x 2051mm	95mm or 100mm	120mm or 125mm	145mm or 150mm
PDKPRO3/**	712mm x 1971mm	1554mm x 2051mm	95mm or 100mm	120mm or 125mm	145mm or 150mm
PDKPRO4/**	788mm x 1971mm	1706mm x 2051mm	95mm or 100mm	120mm or 125mm	145mm or 150mm
PDKPRO6/**	776mm x 2030mm	1682mm x 2110mm	95mm or 100mm	120mm or 125mm	145mm or 150mm
PDKPRO7/**	676mm x 2030mm	1482mm x 2110mm	95mm or 100mm	120mm or 125mm	145mm or 150mm
PDKPRO10/**	880mm x 2305mm	1890mm x 2385mm	95mm or 100mm	120mm or 125mm	145mm or 150mm

*** For full short code please replace with required finished wall thickness size **before** double boarding - 120 or 125 (mm). See calculation above.

Fire Rated Accessories



Round Flush Pull Set (385/S) satin, also available in chrome, polished brass and black



Oval Flush Pull (144S) satin, also available in black

Note: Please refer to the field of application for installation of flush pulls in fire rated applications. This can be found on our website.

POCKET DOOR PRO FIRE RATED Bi-Parting Doors

Fire rated pocket door hardware certified to FD30 standards

NEW

Available
Summer
2020



Pocket Door Pro Fire Rated, for bi-parting doors, contains all the benefits of our Pocket Door Pro kit as well as being certified to FD30 standards. The kit comes complete with intumescent seals and is made out of FDC Finger Jointed Laminated Redwood. The process of finger jointing, combined with a laminated finish, means that the wood is knot and defect free and delivers significantly better product reliability over time.

The system is available in seven different kit sizes, for FD30 installations, self closing or non self closing options as well as simultaneous action. Please consult your building inspector prior to purchase to determine if your application requires a self closer.

The kit should be specified in three parts (see below tables) to combine the certified fire rated liner kit, with the relevant Pocket Door Pro hardware kit plus any required optional extras.

Certification: This system has been independently tested and certified to BS EN 1634-1:2014+A1:2018 standards.

STEP 1: Choose Your Fire Rated Liner Kit

Kit Short Code	Fire Rating	Max. Door Thickness	Finished Wall Thickness	
			Before Double Boarding	After Double Boarding
BIFD30/120	FD30 (30 minutes)	45mm	120mm	145mm
BIFD30/125	FD30 (30 minutes)	45mm	125mm	150mm

STEP 2: Choose Your Pocket Door Pro Kits Two kits must be specified in addition to your fire rated liner kit

Short Code		Max. Door Width	Max. Door Height	Max. Door Weight		Finished Wall Thickness	
Standard (x2 required)	With Soft Stop (x2 required)			Standard	With Soft Close	Before Double Boarding	After Double Boarding
PDKPRO1/***(x2)	N/A	610mm	1981mm	120kg	80kg	120mm or 125mm	145mm or 150mm
PDKPRO2/***(x2)	PROSOFT2/***(x2)	686mm	1981mm				
PDKPRO3/***(x2)	PROSOFT3/***(x2)	762mm	1981mm				
PDKPRO4/***(x2)	PROSOFT4/***(x2)	838mm	1981mm				
PDKPRO6/***(x2)	PROSOFT6/***(x2)	826mm	2040mm				
PDKPRO7/***(x2)	PROSOFT7/***(x2)	726mm	2040mm				
PDKPRO10/***(x2)	PROSOFT10/***(x2)	930mm	2315mm				

Note
Remember to specify two of these kits for your bi-parting doors

*** For full short code please replace with required finished wall thickness size **before** double boarding - 120 or 125 (mm). See calculation on adjacent page.

STEP 3: Choose Your Optional Extras



Self Closing Kit (**BISELF**) (To be used with PROSOFT)

If Using Without a Simultaneous Action Kit
Please purchase x2 BISELF kits

Is Using With a Simultaneous Action Kit

For doors 0-50kg: Please purchase x1 BISELF kit
For doors 50 - 80kg: Please purchase x2 BISELF kits.



Simultaneous Action Kit (**SIM100**) open/close one door and the other will open/close simultaneously



Track Stop (**HH4/AN**) two required if installing non soft closing bi-parting doors

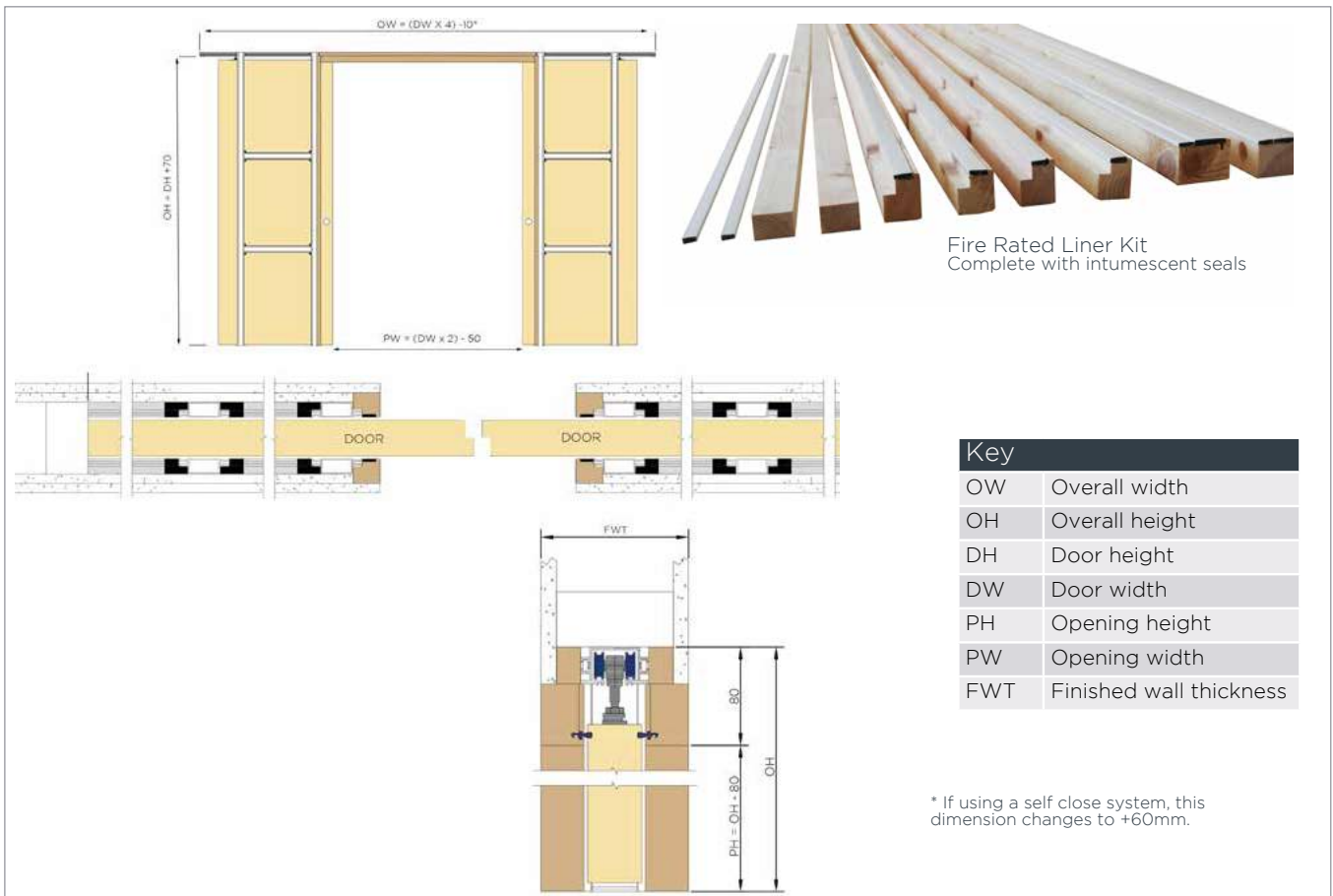

Fire Rated Finished Wall Thickness Calculation

To ensure compliance with BS 476 Part 22 and BS EN 1634 - 12.5mm of extra fire rated board should be applied to either side when using a fire rated liner kit. This brings the finished wall thickness to 145mm or 150mm.

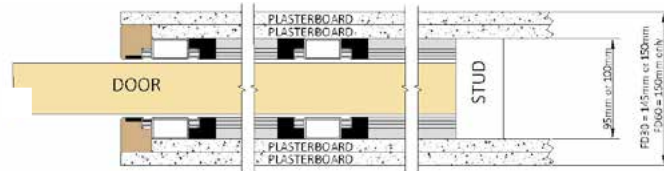

145mm Finished Wall Thickness Calculation

95mm cavity + 12.5mm fire rated board either side = 120mm
+ an additional 12.5mm fire rated board either side = 145mm

150mm Finished Wall Thickness Calculation

100mm cavity + 12.5mm fire rated board either side = 125mm
+ an additional 12.5mm fire rated board either side = 150mm

Opening Size Guide for Bi-Parting Doors

Kit (x2 for bi-parting doors)	Max. Passage Size (W x H)	Overall Dimensions (W x H)	Cavity Thickness	Finished Wall Thickness	
				Before Double Boarding	After Double Boarding
PDKPRO1/***(x2)	1170mm x 1971mm	2480mm x 2051mm	95mm or 100mm	120mm or 125mm	145mm or 150mm
PDKPRO2/***(x2)	1322mm x 1971mm	2784mm x 2051mm	95mm or 100mm	120mm or 125mm	145mm or 150mm
PDKPRO3/***(x2)	1474mm x 1971mm	3088mm x 2051mm	95mm or 100mm	120mm or 125mm	145mm or 150mm
PDKPRO4/***(x2)	1626mm x 1971mm	3392mm x 2051mm	95mm or 100mm	120mm or 125mm	145mm or 150mm
PDKPRO6/***(x2)	1602mm x 2030mm	3344mm x 2110mm	95mm or 100mm	120mm or 125mm	145mm or 150mm
PDKPRO7/***(x2)	1402mm x 2030mm	2944mm x 2110mm	95mm or 100mm	120mm or 125mm	145mm or 150mm
PDKPRO10/***(x2)	1810mm x 2305mm	3760mm x 2385mm	95mm or 100mm	120mm or 125mm	145mm or 150mm

*** For full short code please replace with required finished wall thickness size **before** double boarding - 120 or 125 (mm). See calculation above.

Fire Rated Accessories



Oval Flush Pull
(144S) satin, also available in black

Note: Please refer to the field of application report on our website for installation of flush pulls in fire rated applications.

SOLTAIRE TELESCOPIC

For sliding telescopic wooden doors weighing up to 120kg

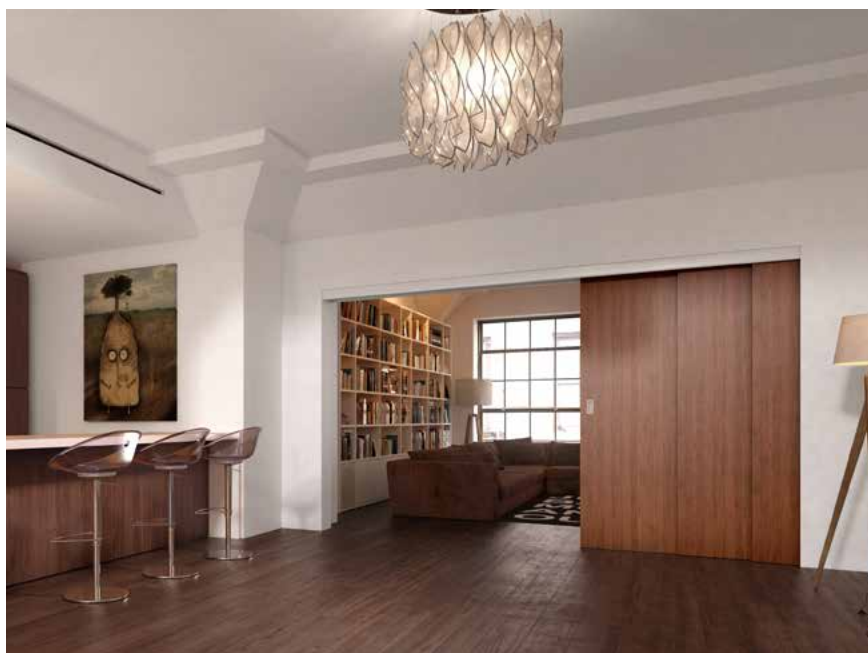

Soltaire Telescopic caters for top hung, telescopic, wooden doors weighing up to 120kg. Designed using a toothed belt and pulley system, the doors are linked together so that as one door is opened or closed, the others will follow. The system also incorporates a coveted ghost guide which keeps the walkway clear and free from trip hazards.

Available in 2, 3 or 4 door variants, the doors can be neatly stacked to the side in front of one another or can also be incorporated into a cavity wall.

This product is particularly suitable for use as partition door systems in homes, offices, hotels and conference rooms.

Product Information

Kit Order Code	No. of Doors	Min. Door Width	Max. Door Width	Door Thickness Range	Max. Door Weight
TEL120/2	2	500mm	1200mm	35 - 47mm	120kg
TEL120/3	3	500mm	1200mm	35 - 47mm	120kg
TEL120/4SIM	4 (2+2)	500mm	1200mm	35 - 47mm	120kg

Track Specification - must be specified in addition to kit

Component	Description	Short Code
Track	Anodised aluminium track in 1500, 2000, 2500, 3000, 3500, 4000, 5000 and 6000mm	120/****

**** Replace by length of track for full short code

Kit Contents

Component	UTEL 2 Quantity	UTEL 3 Quantity	UTEL 4 Quantity
Hanger (51/120/SS)	4	6	8
Track Stop (HH4/AN)	2	2	2
Short Bearing Wheel Assembly	1	2	2
Door Mounted Belt Fixing Bracket	1	2	4
Length of Toothed Belt	1	1	1
Following Door Guide	1	2	2
Fixed Base Floor Guide	1	1	2
Long Bearing Wheel Assembly	1	2	2



Accessories



Round Flush Pull Set (385/S) satin, other finishes available



Square Flush Pull Set (53/S) satin, also available in chrome and black



Oval Flush Pull (144S) satin, also available in black



Rectangle Flush Pull (125/S) satin, also available in chrome

View our full range of accessories on page 136

SIENNA

Stainless steel sliding bar system for wooden doors weighing up to 120kg



Sienna is an elegant sliding system that creates a minimalistic and stylish look. It is designed to accommodate wooden doors of between 30 - 70mm thick and a weight capacity of 120kg. The systems rollers are expertly engineered to effortlessly run along the brushed stainless steel 304 (A2) tubular track and stops are positioned on the track to limit the amount of door travel. For bi-parting doors, two kits can be purchased.



Product Information

Kit Order Code	No. of Doors	Min. Door Width	Max. Door Width	Door Thickness Range	Max. Door Weight
SN120T	1	700mm	2500mm	30 - 70mm	120kg

Track Specification - Must be purchased in addition to kit

Description	Short Code
25mm stainless steel tubular track available in 2000, 2500, 3000, 3500, 4000 and 6000mm lengths Comes complete with correct number of brackets.	25/****T

**** Replace with track length for full short code

Opening Height (OH)

Opening Width (OW)

Panel Width (PW)
PW = OW + 80mm

Door Height (DH)
DH = OH + 80 - 5mm
2500mm max.

51

100

38

30

15

9

Standard Bar	No. of Fixing Plates/Brackets
2000mm	4
2500mm	5
3000mm	6
3500mm	7
4000mm	8

Kit Contents

Component	Short Code
Hangers (x 2)	-
Door Stops (x 2)	25/UDS
Guide (x 1)	101SS
Bar End Caps (x 2)	25/EC

Accessories

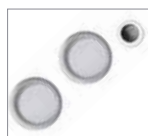

Round Flush Pull Set (385/S) satin, other finishes also available



Oval Flush Pull (144S) satin, also available in black



Rectangle Flush Pull (125/S) satin, also available in chrome

View our full range of accessories on page 136

SIENNA GLASS

Stainless steel sliding bar system for glass doors weighing up to 120kg



This elegant frameless system creates a minimalistic look thanks to the modern design of the stainless steel hangers. The systems specialised rollers have been engineered to effortlessly run along a brushed stainless steel tubular track, enabling this system to be one of the most efficient on the market.

The system has been designed for use with applications requiring glass door to glass wall or glass door to solid wall fixings. Stops positioned on the track limit the door travel. For bi-parting doors - two kits can be used.

For bracket spacing calculations, please see the product datasheet which can be downloaded from our website.

Hangers are grade 304, A2 stainless steel.

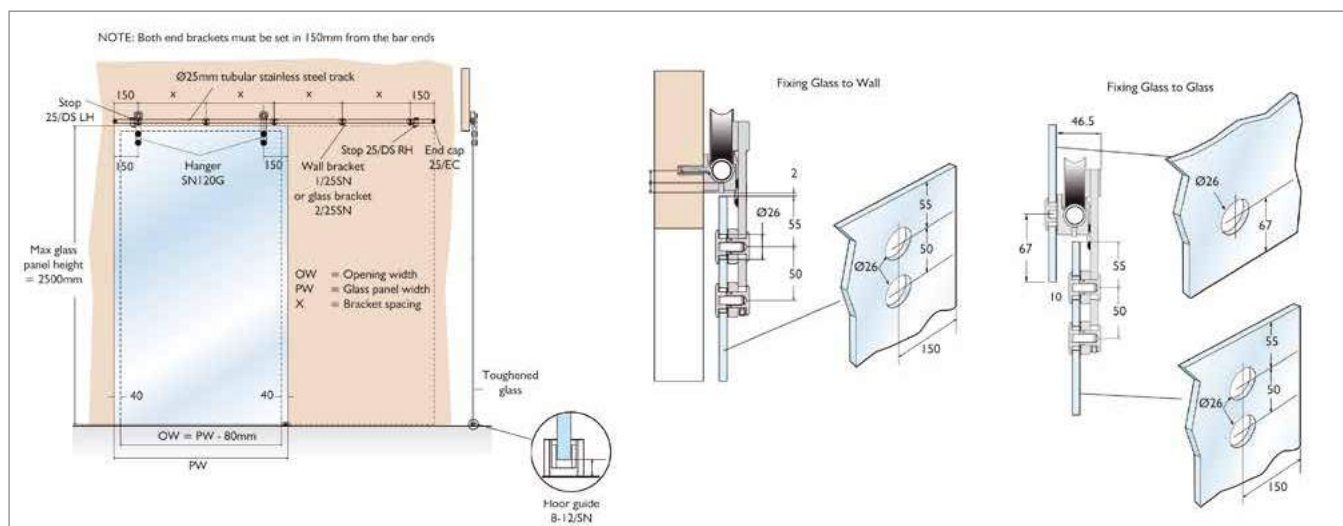

Product Information

Kit Order Code	No. of Doors	Min. Door Width	Max. Door Width	Glass Thickness	Max. Door Weight
SN120G	1	700mm	3000mm	8, 10 or 12mm	120kg

Track and Bracket Specification - Must be purchased in addition to kit

Component	Description	Short Code
Track	25mm stainless steel tubular track in 2000, 2500, 3000, 3500, 4000 and 6000mm lengths	25/****
Brackets <small>View datasheet for details on bracket spacing</small>	Face fixed bracket for solid wall	1/25SN
	Face fixed bracket for glass wall	2/25SN

**** Replace by length of track for full short code

Kit Contents

Component	Short Code
Hangers (x 2)	-
Door Stops (x 2)	25/DSR or 25/DSL
Guide (x 1)	8-12/SN
Bar End Caps (x 2)	25/EC

Accessories

[View our full range of accessories on page 136](#)

PACER GLASS

For sliding glass doors weighing up to 130kg and 180kg



Pacer Glass is a sophisticated system which accommodates both sliding glass panels making it ideal for interior dividers in offices and shops as well as more modern applications in new developments. The nature of these applications require quality aesthetic finishes and, to meet this demand, Pacer has a specially designed clip on fascia for both soffit fixed and face fixed applications.

Product Information

Product	Max. Door Width	Glass Thickness	Max. Door Weight
Pacer Glass	3000mm	8, 10 or 12mm	130kg or 180kg

Product Specification

Component	Description	130kg System	180kg System
Track	Anodised aluminium track in 2000, 2500, 3000, 3500, 4000, 5000 & 6000mm	600/****AN	600/****AN
	Aluminium mill finish track in 2000, 2500, 3000, 3500, 4000, 5000 & 6000mm	600/****	600/****
Brackets	Face fixed bracket	1B	1B
	Jointing bracket	1BX	1BX
Glass Clamp Kit Consists of two 56 hanger assemblies, two glass clamp assemblies, a universal guide and two 60IP retaining stops	Glass clamp kit for 8mm glass	8/PA/130	8/PA/180
	Glass clamp kit for 10mm glass	10/PA/130	10/PA/180
	Glass clamp kit for 12mm glass	12/PA/130	12/PA/180
Floor Guide	Floor guide for 8, 10 or 12mm glass	8-12/SN	8-12/SN
Fascia	Fascia for soffit fixed track in 2000, 2500, 3000, 3500, 4000 & 6100mm	F160/****	F160/****
	Fascia for face fixed track in 2000, 2500, 3000, 3500, 4000 & 6100mm	F200/****	F200/****
Fascia Endcaps	End cap for F160 fascia	F160/ECP	F160/ECP
	End cap for F200 fascia	F200/ECP	F200/ECP

Hardware

Track



600AN



600

Brackets



1B



1BX

Glass Clamp Kit



/PA/*

Floor Guide



8-12/SN

Fascia



F160



F160/ECP



F200



F200/ECP

**** Replace by length of track for full short code

Accessories

View our full range of accessories on page 136

PACER SLIDING

For wooden and metal sliding doors weighing up to 200kg



Combining performance and style, Pacer Sliding is suitable for wooden, aluminium or metal doors weighing up to 200kg. The system is ideally suited to modern applications including offices, shop fronts and other stylish interiors. Various guide channels are available including brass, aluminium and an aluminium threshold. A track mounted aluminium fascia is also available for face fixed and soffit fixed applications to conceal the working components. Wooden doors may be either solid or glazed and metal doors can be angle or box section.



Product Information

Product	Door Thickness Range	Max. Door Weight
Pacer Sliding	35 - 46mm	200kg

Product Specification

Component	Description	Short Code
Track	Aluminium mill finish track in 2000, 2500, 3000, 3500, 4000, 5000 & 6000mm	600/****
	Anodised aluminium track in 2000, 2500, 3000, 3500, 4000, 5000 & 6000mm	600/****AN
Brackets	Face fixed bracket	1B
	Jointing bracket	1BX
Hangers	Angle plate fixing hanger for wooden doors	52B
	Hanger for angle frame metal doors	56B
	Hanger for box frame metal doors	56BX
	Concealed fixing hanger for wooden doors, aluminium doors or metal doors	57B
Guides	Floor mounted guide for wooden, aluminium or metal doors	89/2N
	Concealed fixing guide for wooden or aluminium doors	106N/94
	Guide for angle frame metal doors	104N/94
	Guide for box frame metal doors	104NX/94
Guide Channel	Brass guide channel available in 1500 and 3000mm lengths	94/****
	Aluminium guide channel in 1500, 2000, 2500, 3000, 4000 and 6000mm lengths	94X/****
	Aluminium threshold in 2000, 2500, 3000, 3500, 4000 and 6000mm lengths	94T/****
	Polypropylene channel in black in 2000, 2500, 3000, 3500, 4000, 5000 and 6000mm lengths	94P/****
Stop	Retaining stop mounted within track	601P
Fascia	Aluminium fascia for soffit fixed track in 2000, 2500, 3000, 4000 and 6100mm	F160/****
	Aluminium fascia for face fixed track in 2000, 2500, 3000, 3500, 4000 and 6100mm	F200/****
Fascia End Caps	End cap for F160 fascia	F160/ECP
	End cap for F200 fascia	F200/ECP

**** Replace by length of track for full short code

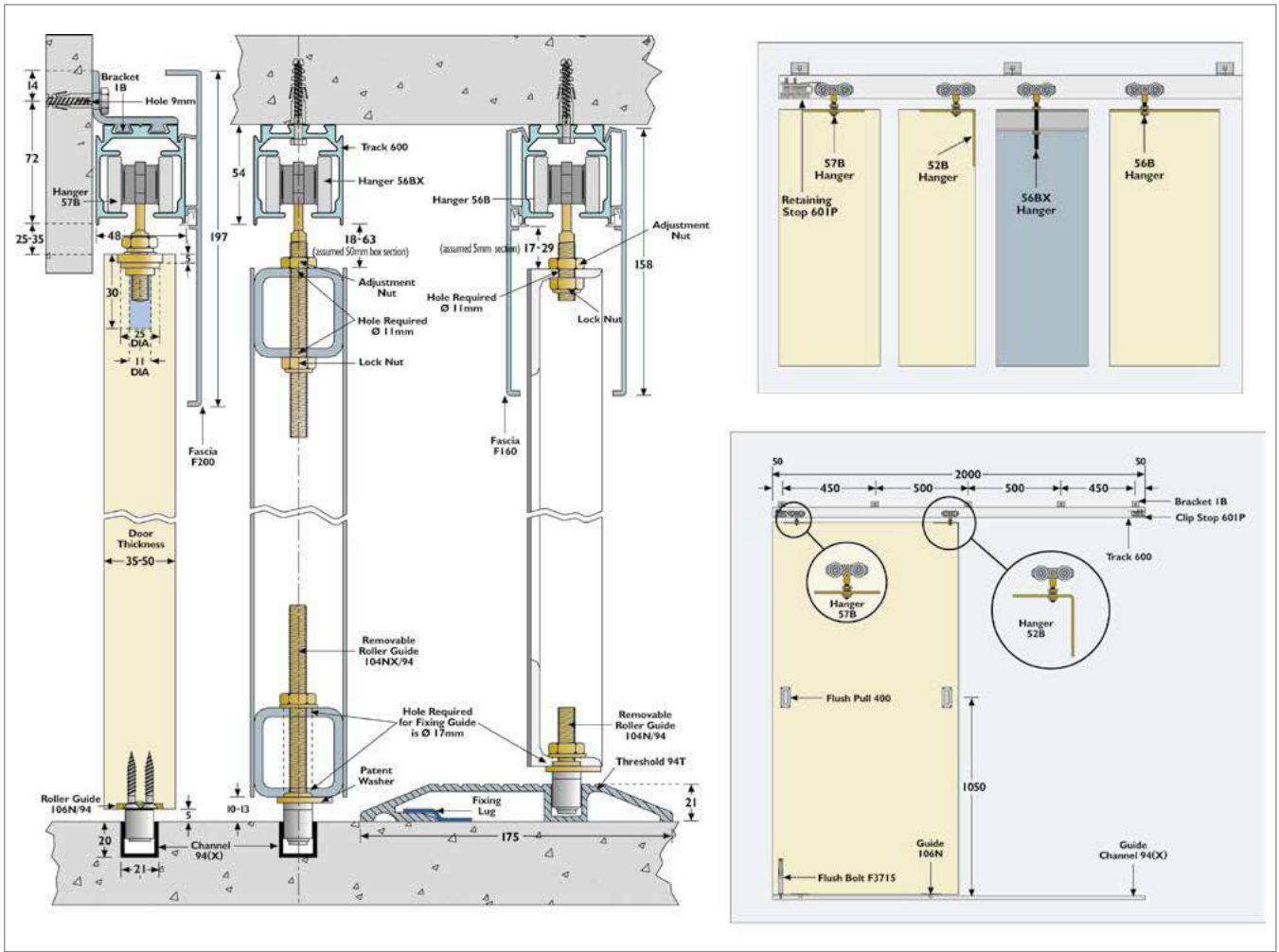

Hardware

Track



600

Brackets



600AN



1B



1BX

Hangers



52B



56B



56BX



57B

Guides



89/2N



106N/94



104N/94



104NX/94

Guide Channel



94



94X

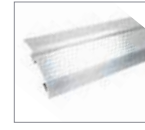

94T

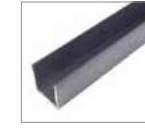

94P

Stop



60IP

Fascia

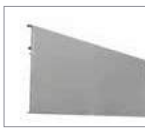

F160



F160/ECP



F200



F200/ECP

Accessories



Round Flush Pull Set (**385/S**) satin, other finishes also available



Square Flush Pull Set (**53/S**) satin, also available in chrome and black



Oval Flush Pull Set (**144S**) satin, also available in black



Rectangle Flush Pull Set (**125/S**) satin, also available in chrome

View our full range of accessories on page 136

IMPERIAL

Watch the Installation Video
pchenderson.com/imperial-installation



For bottom rolling sliding wooden doors weighing up to 200kg



Imperial is ideal for bottom rolling patio doors and straight sliding room partitions for residential and commercial applications. The bottom rolling system allows the system to be installed where there is insufficient support for a top hung system and therefore requires very little structural support. To cover the width of the opening, any number of doors can be used on single or multiple lines of track; doors can also slide to one or both sides.

Ready-made kit packs are available as locking and non-locking versions. The locking version comes complete with a high security 6 hook lock and keep plate. To allow increased flexibility, Imperial is also able to be specified as individual parts if you would like to put together a unique system to better suit your individual requirements.

Imperial Patio Kit Information - use the below tables when specifying Imperial in kit pack format

Product	Kit Short Code	Functionality	Track Length	No. of Doors	Max. Door Width	Door Thickness Range	Max. Door Weight
Imperial Patio Kit	IMPATIO/L	Locking	3000mm	1	1500mm	40 - 56mm	200kg
	IMPATIO/NL	Non Locking					

Imperial Patio Kit Contents

Component	Short Code
Bronze Bottom Rail (x1)	915B/3000
Polypropylene Channel (x1)	94P/3000
Stainless Steel Door Stops (x2)	DS200/SS
2.4m Interlocking Profile (x2)	INTPROF/24
Stainless Steel Twin Wheel Rollers (x2)	200SS
Heavy Duty Stainless Steel Top Guides (x2)	106SS/94
6 Hook Lock Kit (x 1) (included in Imperial Locking Kit only)	-

Note: Doors must be constructed with bottom rails of at least 150mm depth to accommodate the concealed, morticed bottom rollers.

Door weight is carried on the floor permitting the use of a light overhead structure.

Door seals are not supplied by P C Henderson.

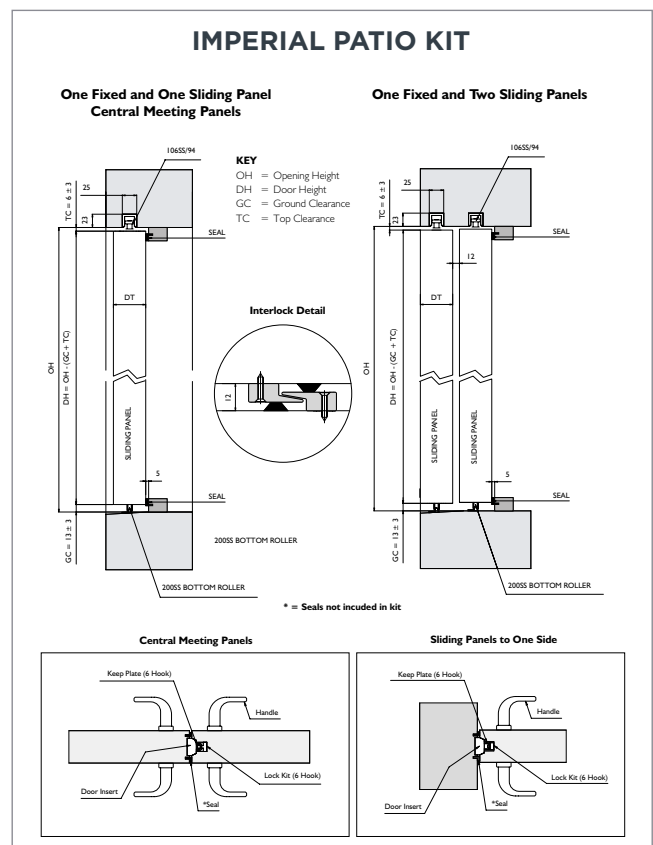

Imperial Product Information - Use the below tables when specifying parts individually

Product	Max. Door Width	Door Thickness Range	Max. Door Weight
Imperial	3000mm	40 - 56mm	100kg or 200kg

Product Specification

Component	Description	Short Code	
		100kg	200kg
Top Guide Channel	Aluminium channel in 1500, 2000, 2500, 3000, 4000 and 6000mm	94X/****	-
	Polypropylene channel in 2000, 2500, 3000, 3500, 4000, 5000 & 6000mm	94P/****	-
	Aluminium support channel in 2000, 2500, 3000, 3500, 4000, 5000 and 6000mm (to be used with 94P channel)	94SC/****	-
	Stainless steel channel in 2000 and 3000mm lengths	89/****SS	-
	Aluminium channel with safety lip in 2000, 2500, 3000, 4000 and 6000mm	-	900AN/****
Bottom Rail	Aluminium mill finish bottom rail in 1500, 2000, 2500, 3000, 4000 and 6000mm	915A/****	-
	Bronze bottom rail available in 1500, 2000, 2500, 3000, 4000 and 6000mm	-	915B/****
Brackets Fitted at 900mm maximum centres	Stainless steel face fixed bracket (compatible with 900AN)	-	1/SS
Top Guide Rollers 2 Per Door	Top plate fitting top guide (for 94 channel)	106HSS/94	-
	Corner fitting top guide (for 94 channel)	113SS/94	-
	Torpedo HDPE fitting top guide complete with stainless steel screws (for 89 or 94 channel)	89/2N/SS	-
	Top guide roller with concealed edge fixings (for 900 channel)	-	104/900
	Top guide roller for corner fixing (for 900 channel)	-	54/900
	Stainless steel top guide with double nylon rollers, one adjustable laterally to prevent rattle (for 900 channel)	-	261SS/900
Bottom Rollers 2 per door	Stainless steel bottom roller with precision ball bearing wheels with side access vertical adjustment	200SS	
Interlocking Profile	Interlocking profile 2.4m	INTPROF/24	
Stops	Floor stop	DS200/SS	-
	Track mounted stop for 900AN channel	-	HH2/SS

Hardware

Top Guide Channel  94X  94P  94SC  89  900AN				Bottom Rail  915A  915B		Bracket  1/SS
Top Guide Rollers  106HSS/94  113SS/94  89/2N/SS  104/900  54/900			Bottom Rollers  261SS/900  200SS		Profile  INTPROF/24	
Stops  DS200/SS  HH2/SS						

Accessories

	Rectangular Flush Pull (400) in satin, also available in stainless steel	View our full range of accessories on page 136
---	---	---

SOLTAIRE



Watch the Installation Video
pchenderson.com/soltaire-installation



Top hung straight sliding door system for doors weighing up to 120kg, 180kg and 250kg

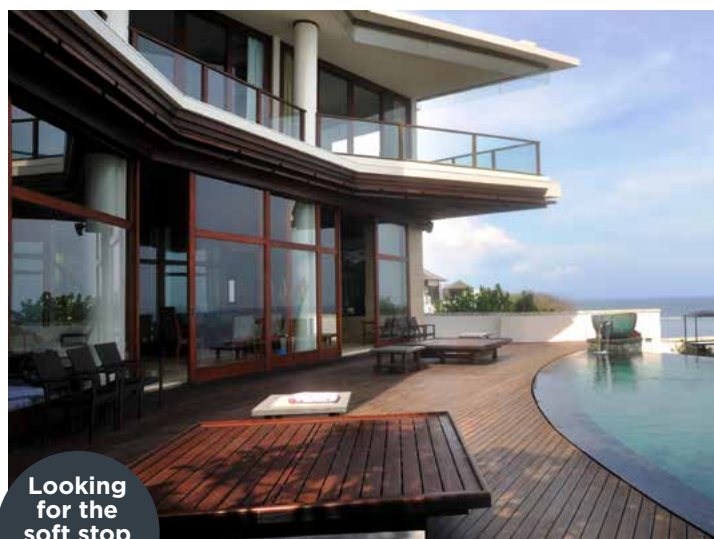

Looking for the soft stop version?
See page 50

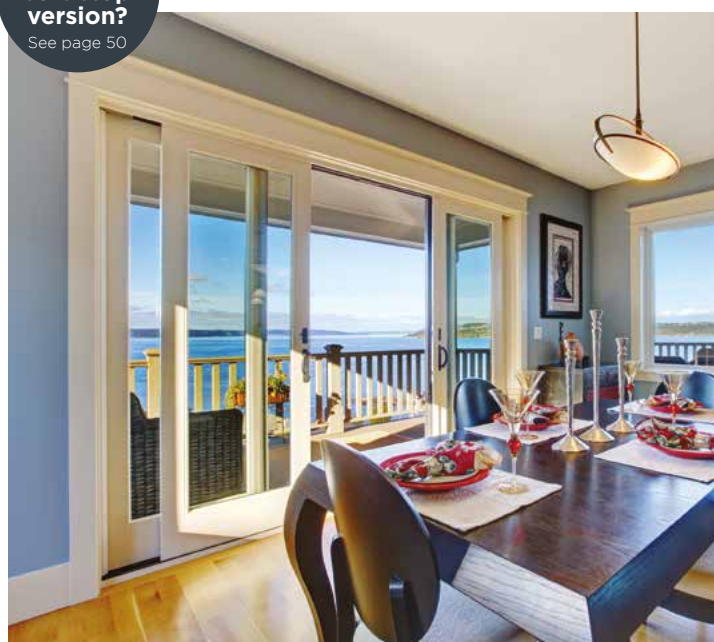

Soltaire is a beautifully crafted top hung sliding system designed to accommodate interior and exterior doors of one sliding panel or two bi-parting doors on a single track. Designed for door weights up to 120kg, 180kg or 250kg the system is ideal for residential or commercial applications. Manufactured from marine grade 316 stainless steel the system is ideal for coastal environments due to its weather and corrosion resistant properties.

Soltaire is available in ready made kits for ease of installation as well as being able to be specified as individual components. The system is also available in Soft Close (page 50), Low Headroom (page 51) and folding variants (page 80).

The track can be soffit fixed or face fixed for flexibility of installation.

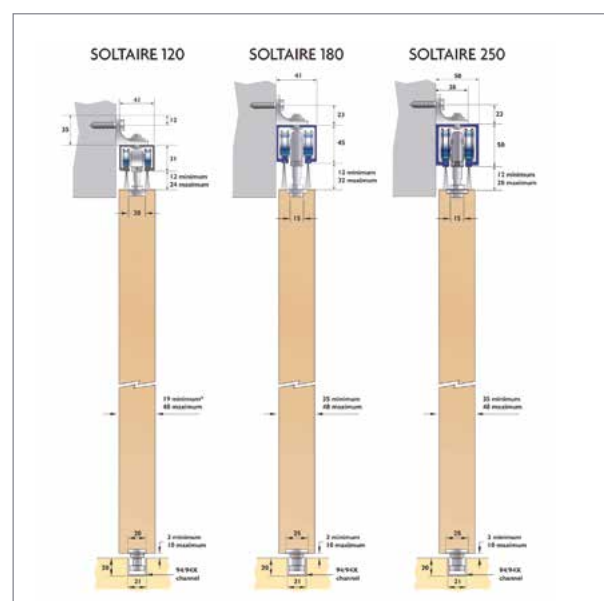

Soltaire Kit Pack Information* - use the below tables when specifying Soltaire in kit pack format

Product	Kit Short Code (Internal)	Kit Short Code (External)	Track Length	No. of Doors	Max. Door Width	Door Thickness Range	Max. Door Weight
Soltaire 120	S120/20ANI	S120/20AN	2000mm	1	1000mm	24 - 48mm	120kg
Soltaire 180		S180/30AN	3000mm	1	1500mm	35 - 48mm	180kg
Soltaire 250		S250/30AN	3000mm	1	1500mm	35 - 48mm	250kg

Soltaire Kit Pack Contents

Component	Soltaire 120 Internal	Soltaire 120 External	Soltaire 180	Soltaire 250
Track	120/2000 (x1)	120/2000 (x1)	180/3000 (x1)	250/3000 (x1)
Hangers	51/120/SS (x2)	51/120/SS (x2)	57/180/SS (x2)	57/250/SS (x2)
Guide	101SS (x1)	106SS/94 (x2)	106HSS/94 (x2)	106HSS/94 (x2)
Track Stops	HH4/AN (x2)	HH4/AN (x2)	HH5/AN (x2)	HH5/AN (x2)
Face Fix Brackets	1/SS (x4)	1/SS (x4)	1/SS (x5)	1/SS (x5)
Flush Pulls	144S (x2)	144S (x2)	144S (x2)	144S (x2)
Guide Channel	-	94X/2000 (x1)	94X/3000 (x1)	94X/3000 (x1)

*Can also be specified as individual components, see adjacent page for details

Soltaire Product Information - use the below tables when specifying parts individually

Product	Max. Door Width	Door Thickness Range	Max. Door Weight
Soltaire 120	3000mm	19 - 48mm	120kg
Soltaire 180	3000mm	35 - 48mm	180kg
Soltaire 250	3000mm	35 - 48mm	250kg

Product Specification

Component	Description	120	180	250
Track	Anodised alum. track in 2000, 2500, 3000, 3500, 4000, 5000 & 6000mm	120/****	180/****	250/****
Brackets	Face fixed stainless steel bracket (600mm spacing)	1/SS	1/SS	1/SS
	Face fixed double run stainless steel bracket (900mm spacing)	5/SS	5H/SS	5H/SS
Hangers	Face fixing hanger for MDF doors	52/120/SS	-	-
	Top fixed, surface mounted hanger for wooden and metal doors	51/120/SS	-	-
	Concealed plate fixing hanger for wooden doors	57/120/SS	57/180/SS	57/250/SS
	Corner plate fixing hanger for wooden doors	-	52/180/SS	52/250/SS
	Saddle plate fixing hanger for wooden doors	-	53/180/SS	53/250/SS
	Angle frame hanger for metal doors	56/120/SS	56/180/SS	56/250/SS
Guides	Box frame hanger for metal doors	-	56X/180/SS	56X/250/SS
	Side mounted guide	105SS/94	105SS/94	105SS/94
	Concealed fixing guide with stainless steel bearings	106SS/94	106HSS/94	106HSS/94
	Floor guide	101SS	101SS	101SS
	Wall mounted guide	102SS/94	102SS/94	102SS/94
	Bottom guide for angle frame metal door	104P/89	104P/89	104P/89
Channels	Bottom guide for box section metal door	104PX/89	104PX/89	104PX/89
	Aluminium guide channel in 1500, 2000, 2500, 3000, 4000 & 6000mm	94X/****	94X/****	94X/****
	Stainless steel channel available in 2000 and 3000mm lengths	89/****SS	89/****SS	89/****SS
	Polypropylene channel in black available in 2000, 2500, 3000, 3500, 4000, 5000 and 6000mm lengths	94P/****	94P/****	94P/****
Brush Strips	Anodised aluminium support channel available in 2000, 2500, 3000, 3500, 4000, 5000 and 6000mm lengths (to be used in with 94P channel)	94SC/****	94SC/****	94SC/****
	Brush track seal in black in 10, 15, 20 and 25mm brush heights (per metre)	BS**B	BS**B	BS**B
Track Stop	Track stop	HH4/AN	HH5/AN	HH5/AN

****Replace with length of track for full short code ** Replace with height of brush strip for full short code

Hardware

Track 120 180 250			Brackets 1/SS 5/SS 5H/SS			Hangers 52 51		
Hangers 57 53 56			Guides 56X 105SS 106HSS			101SS 102SS		
Guides 104P 104PX			Channels 94X 89SS 94P 94SC			Brush Strip BS**B		Track Stop HH4 or HH5

Accessories

NEW
Available
Summer
2020



Simultaneous Action Kit (**SIM100**) for two bi parting doors



Round Flush Pull Set (**385/S**) satin, also available in chrome, polished brass and black

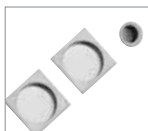

Square Flush Pull Set (**53/S**) satin, also available in chrome and black



Oval Flush Pull (**144S**) satin, also available in black

SOLTAIRE SOFT CLOSE

Soft closing sliding system for doors weighing up to 80kg



Soltaire Soft Close has been developed to enhance the sophistication and convenience of the Soltaire system even further.

Suitable for wooden and metal doors weighing up to 80kg, Soltaire Soft Close gently decelerates the door upon closing, gliding it into position for the final 90mm of travel. Unlike other soft close mechanisms, which traditionally lie underneath the track, the Soltaire Soft Close system is contained within the track itself, offering an extremely quiet, reliable and discreet activation of the mechanism.

The system can be used on both the opening and closing side of the door, with a high quality damper at the key of the system which will work maintenance free throughout its lifetime.

Please choose your required kit according to which hanger type you require (please see below).

Product Information

Kit Short Code	Damper Type	Hanger Apron Plate Type	Door Thickness Range	Max. Door Weight
51SD80	Single Damper	Top fixed, surface mounted hanger for wooden doors	24 - 48mm	80kg
51SD80D	Double Damper			
52SD80	Single Damper	Face fixed hanger for MDF doors	19 - 23mm	80kg
52SD80D	Double Damper			
56SD80	Single Damper	Angle framed hanger for metal doors	19 - 48mm	80kg
56SD80D	Double Damper			
57SD80	Single Damper	Concealed plate fixing hanger for wooden doors	24 - 48mm	80kg
57SD80D	Double Damper			

Track, Guide, Channel and Bracket Specification - must be purchased in addition to kit

Component	Short Code	Description
Track	120/****	Anodised aluminium track in 2000, 2500, 3000, 3500, 4000, 5000 and 6000mm lengths
Guides	106SS/94	Concealed guide for doors weighing up to 120kg
	102N	Nylon saw cut guide
	102SS/94	Wall mounted guide
	101SS	Floor guide, stainless steel
Channel Requirement depends on which guide is chosen	94X/****	Aluminium guide channel in 1500, 2000, 2500, 3000, 4000 and 6000mm lengths
	94P/****	Polypropylene channel in 2000, 2500, 3000, 3500, 4000, 5000 and 6000mm lengths
Brackets For face fixed installations	1/SS	Stainless steel face fixed bracket
	5H/SS	Stainless steel face fixed double bracket

****Replace with length of track for full short code

Kit Contents

Single Damper	Double Damper
Damper Assembly (x 1)	Damper Assembly (x 2)
Hanger and Apron Plate Assembly (x 1)	Hanger and Apron Plate Assembly (x 2)
Track Stop (x 1)	Trigger Block (x 2)
Trigger Block (x 1)	

Accessories



Self Closing Kit (BISELF)

If Using Without a SIM Kit
Please purchase x2 BISELF kits

If Using With a SIM Kit

For doors 0-50kg: Please purchase x1 BISELF kit
For doors 50 - 80kg: Please purchase x2 BISELF kits.



Simultaneous Action Kit (SIM100)

open/close one door and the other will open/close simultaneously

View our full range of accessories on page 136

SOLTAIRE LOW HEADROOM

Top hung straight sliding system for doors weighing up to 120kg, 180kg and 250kg



Soltaire Low Headroom kit is ideal for top hung sliding door systems with low or restricted headroom. The system is designed to accommodate interior wooden doors of one sliding panel or two bi-parting doors on a single track.

Catering for doors weighing up to 120kg, 180kg or 250kg, the kit is designed to reduce the clearance between the track and top of the door to 2mm - making the hardware barely visible.



Product Information

Kit Short Code	Max. Door Width	Door Thickness Range	Max. Door Weight
LH120A	3000mm	35 - 48mm	120kg
LH180A	3300mm	35 - 48mm	180kg
LH250A	3300mm	35 - 48mm	250kg

Track, Guide Channel and Bracket Specification - must be purchased in addition to kit

Component	Description	Soltaire 120 Short Code	Soltaire 180 Short Code	Soltaire 250 Short Code
Track	Anodised aluminium track in 2000, 2500, 3000, 3500, 4000, 5000 and 6000mm lengths	120/****	180/****	250/****
Channel	Aluminium channel available in 1500, 2000, 2500, 3000, 4000 and 6000mm lengths	94X/****	94X/****	94X/****
Guides	Concealed guide for doors weighing up to 120kg	106SS/94	106SS/94	106SS/94
	Concealed guide for doors weighing up to 180kg and 250kg	106HSS/94	106HSS/94	106HSS/94
	Wall mounted guide for doors weighing up to 180kg and 250kg	102SS/94	102SS/94	102SS/94
Brackets	Stainless steel single run face fixed bracket	1/SS	1/SS	1/SS

Hardware



Kit Contents

Component	Short Code
Channel Bodies (x 2)	-
End Cap (x 2)	-
Strap Bolt (x 2)	-
Hanger (x 2)	-
Door Stop (x 2)	HH4/AN
4mm Allen Key (x 1)	-
Screw Pack (x 1)	-

Accessories

				<p>View our full range of accessories on page 136</p>
<p>Round Flush Pull Set (385/S) satin, also available in chrome, polished brass and black</p>	<p>Square Flush Pull Set (53/S) satin, also available in chrome and black</p>	<p>Oval Flush Pull (144S) satin, also available in black</p>	<p>Rectangle Flush Pull (125/S) satin, also available in chrome</p>	

STAINLESS STEEL

A stainless steel tailor made solution for light to heavyweight sliding doors exposed to high levels of corrosion



For areas exposed to extreme levels of corrosive elements or where a high level of hygiene is essential, P C Henderson has developed a range of stainless steel sliding door hardware. Manufactured from high quality stainless steel and incorporating the latest polymers, this product offers a high level of performance and corrosion resistance.

Stainless Steel can be used for an array of applications including chemical factories, oil rigs, abattoirs, cold storage, food processing plants and areas exposed to salt water. Whatever the conditions, Stainless Steel will perform.

NOTE: Fixing plates, bolts and nuts are Grade 304 (A2) Stainless Steel. The Stainless Steel range cannot be used with P C Henderson's standard range of products.

Product Information

Product	Door Thickness Range	Max. Door Weight
Stainless Steel 280	20 - 50mm	50kg or 100kg
Stainless Steel 290	35 - 48mm	150kg
Stainless Steel 301	43 - 57mm	270kg

Product Specification

Component	Description	SS 280	SS 290	SS 301
Track	Grade 316L(A4) stainless steel track available in 2000 and 3000mm lengths	280/****SS	290/****SS	301/****SS
Hangers	Hanger for wooden doors	284N/SS (50kg) or 284/SS (100kg)	-	-
	Hanger for metal doors	285N/SS (50kg) or 285/SS (100kg)	56/290SS	56/301SS
	Hanger for apron plate fixing	-	53/290SS	53/301SS
	Hanger for top plate fixing	-	57/290SS	57/301SS
Brackets Recommend- ed spacing is 600mm in case of maximum load 500mm.	Face fixed bracket	281SS	1/290SS	1/301SS
	Face fixed jointing bracket	-	1X/290SS	1X/301SS
	Soffit fixed bracket	-	3/290SS	3/301SS
	Soffit fixed jointing bracket	-	3X/290SS	3X/301SS
	'In line' soffit fixed bracket	-	4/290SS	4/301SS
	'In line' soffit fixed jointing bracket	-	4X/290SS	4X/301SS
	'Bolt on' soffit fixed bracket	4R/280SS	4R/290SS	4R/301SS
	'Bolt on' soffit fixed jointing bracket	4RX/280SS	4RX/290SS	4RX/301SS
Channel	Stainless steel channel in 2000 or 3000mm lengths	89/****SS	89/****SS	89/****SS
Guides	Single door floor guide	89/2N/SS	89/2N/SS	89/2N/SS
	Wall mounted guide for single door	31S/SS	31S/SS	31S/SS
Stops	Single buffer wall mounted door stop	109/SS	109/SS	109/SS
	Track stop	287SS	HH3/290/SS	HH3/301/SS

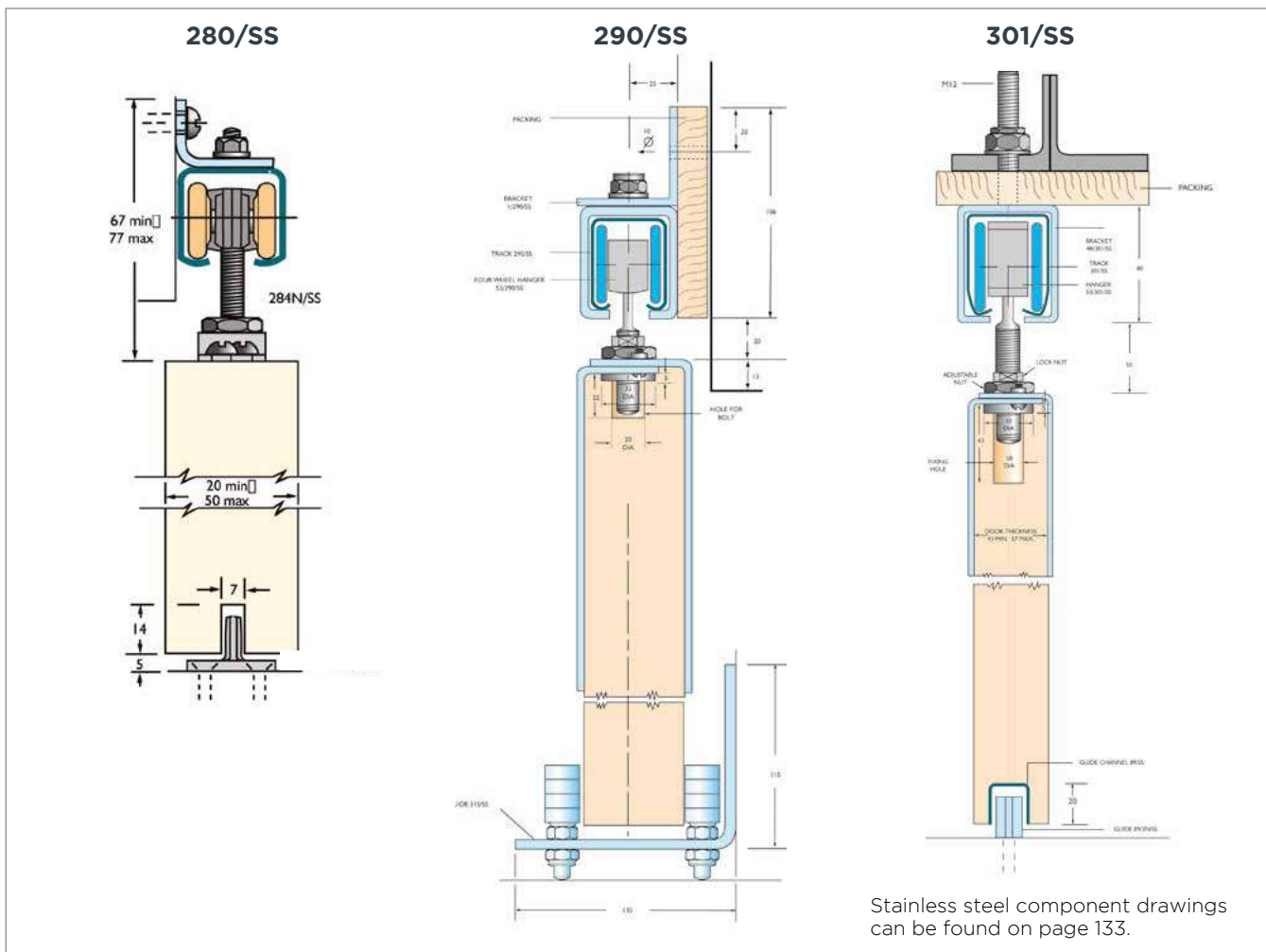

Hardware

Track



280



290



301

Hangers



284N



284



285N



285



56

Hangers



53



57

Brackets



281



1



1X



3



3X



4

Brackets



4X



4R



4RX

Channel



89

Guides



89/2N



31S

Stops



109



287



HH3

Accessories



Flush Pull
(400SS)
Stainless Steel

View our full range of accessories on page 136

MAJESTIC

For bottom rolling straight sliding doors weighing up to 270kg



Majestic is a durable system perfectly suited for heavy high class joinery installations weighing up to 270kg. Majestic features a concealed bottom roller enabling the weight of the door to be transferred to the bottom track, making it ideal for applications where there is not enough structural support to carry a top hung system.

NOTE: At least 175mm depth at the bottom of the door must be available to accommodate the concealed bottom rollers when choosing this system.

Product Information

Product	Door Thickness Range	Max. Door Weight
Majestic	44 - 57mm	270kg

Product Specification

Component	Description	Short Code
Top Guide Channel Twice the width of doors	Galvanised steel top guide channel with safety lip in 2000, 2500 and 3000mm	900/****
Brackets Fix every 900mm max. and at channel joints	Face fixed single track bracket	1/900
	Soffit fixed single track bracket	3/900
	Face fixed double track bracket	5/900
Top Guide Rollers 2 per door	Top guide rollers with concealed edge fixings and double adjustable anti-rattle rollers	203/900
	Top guide roller for corner fixing	54/900
Bottom Rollers 2 per door	Brass wheel bottom roller with maintenance free roller bearing	916
Bottom Rail	Brass bottom rail available in 1500 and 3000mm lengths	917/****
	Brass recessed bottom rail - 3000mm length	817/3000
Stop	Zinc plated steel door stop with single rubber buffer	109
	Stainless steel door stop with single rubber buffer	109/SS
	Zinc plated steel with double rubber buffer	107

**** Replace by length of track for full short code



SECTION DETAILS

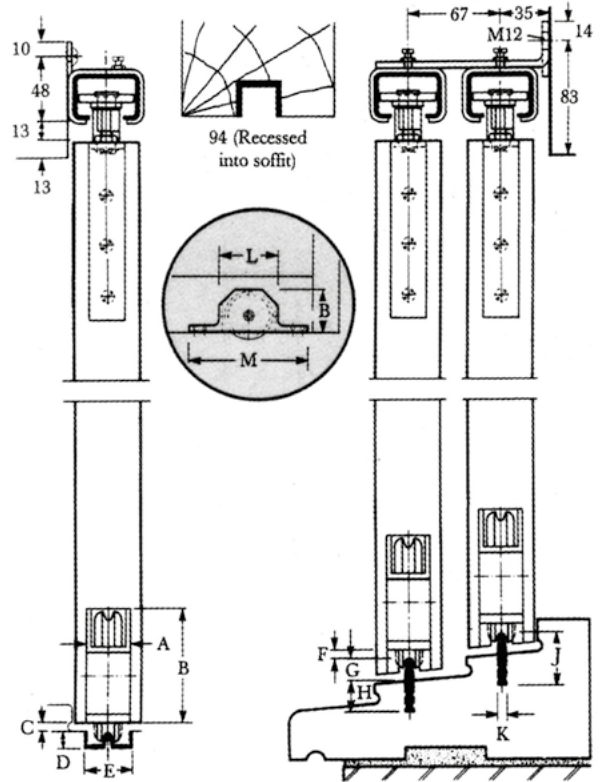

Dimensions										
A	B	C	D	E	F	G	H	J	K	M
32	82	6	13	35	6	16	22	38	8	111

Hardware

Guide Channel



900

Brackets



1/900



3/900



5/900

Top Guide Rollers



203/900



54/900

Bottom Rollers



916

Bottom Rail



917



817

Stops



109



109/SS



107

Accessories



Round Flush Pull Set (385/S) satin, also available in chrome, black and polished brass



Square Flush Pull Set (53/S) satin, also available in chrome and black



Oval Flush Pull (144S) satin, also available in black



Rectangle Flush Pull (125/S) satin, also available in chrome



Rectangle Flush Pull (400) satin, also available in stainless steel



Rectangle Flush Pull (414) aluminium, heavy duty



Lug for Fixing Rails into Concrete (917/918LUG)



Cup for Fixing Rails into Concrete (UNICUP)

View our full range of accessories on page 136

FLEXIROL SLIDING

For sliding wooden or metal doors weighing up to 500kg



Flexirol is a unique system ideally suited to large doors which require high performance as well as an attractive finish. It's an ideal product for hotels, offices, conference centres, shop fronts and showrooms where durability and design are paramount. The product caters for wooden or metal doors fabricated from either angle frame or box section with aluminium extrusion. The track can be soffit fixed or face fixed for flexibility of installation.

Product Information

Product	Max. Door Width	Door Thickness Range	Max. Door Weight
Flexirol Sliding	6000mm	40 - 100mm	500kg

Product Specification

Component	Description	Short Code
Track	White aluminium track in 2000, 2500, 3000, 4000, 5000 and 6000mm lengths	550/****
	Mill finish track in 2000, 3000, 4000, 5000 and 6000mm lengths	550/****M
Brackets Spaced every 750mm	Face fixed bracket	1A/550
	Suspended soffit fixed ceiling bracket with vertical adjustment	3S/550
Hangers 2 per door	Hanger for metal doors	556
	Hanger for wooden doors with concealed fixing	556/57
	Hanger for wooden doors with angle plate fixing	556/52
Guides	Guide for wooden and metal doors, 1 per door (metal doors should also use 94X channel)	89/2N
	Guide for wooden doors 2 per door	106N/94
	Guide for metal doors 2 per door	104N/94
Guide Channel	Brass guide channel in 1500 and 3000mm lengths	94/****
	Aluminium guide channel in 1500, 2000, 2500, 3000, 4000 and 6000mm lengths	94X/****
	Aluminium threshold in 2000, 2500, 3000, 3500, 4000 and 6000mm lengths	94T/****
Stop 2 per door	Track stop	HH3/301

****Replace with length of track or rail for full short code

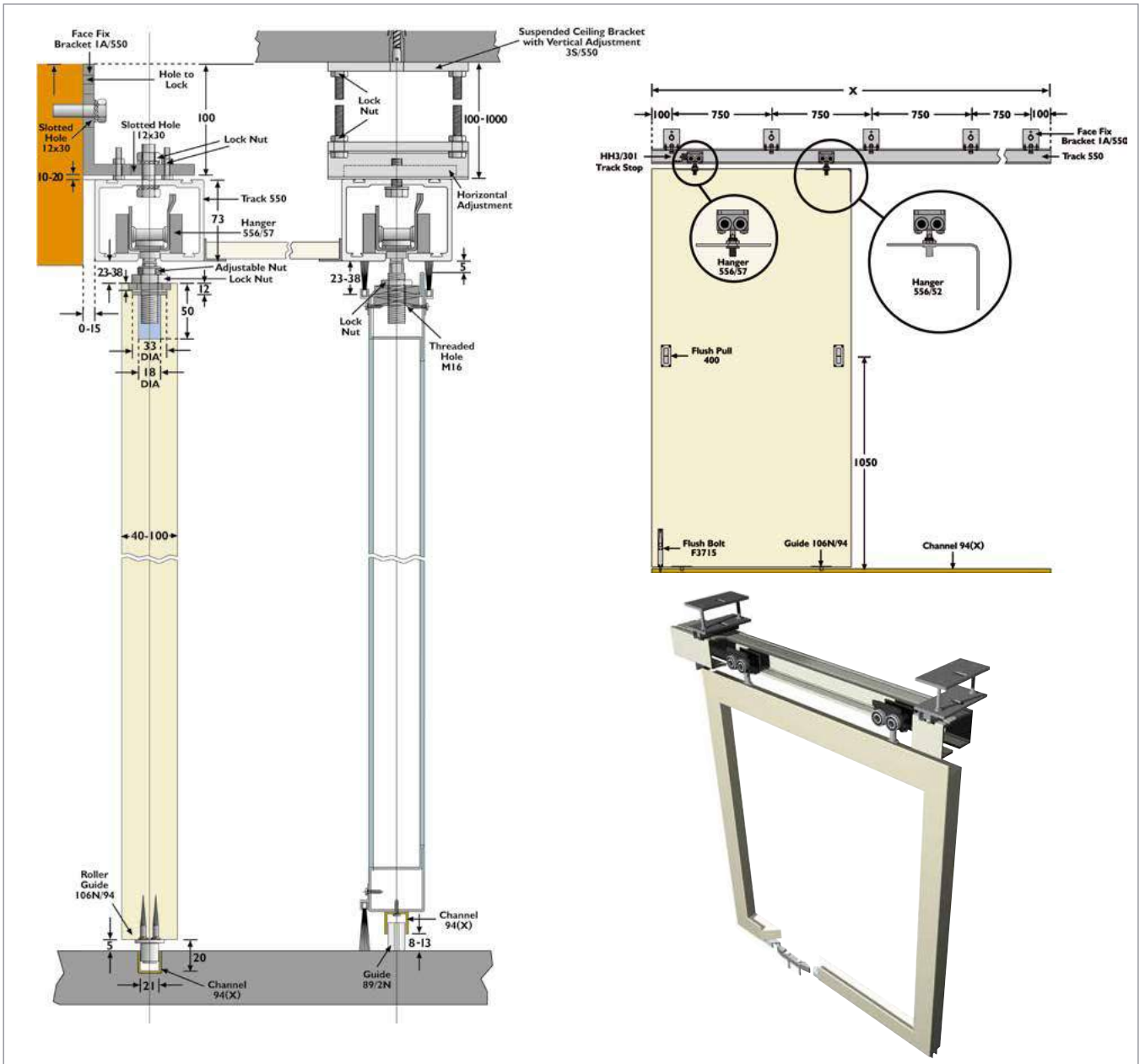

Hardware

Track



550



550M

Brackets



1A/550



3S/550

Hangers



556



556/57



556/52

Guides



89/2N



106N/94



104N/94

Guide Channel



94

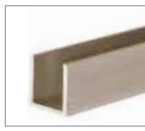

94X

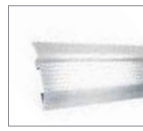

94T

Stop



HH3

Accessories



Round Flush Pull Set (385/S) satin, also available in chrome, black and polished brass



Square Flush Pull Set (53/S) satin, also available in chrome and black



Rectangle Flush Pull (125/S) satin, also available in chrome



Rectangle Flush Pull (400) satin, also available in stainless steel

View our full range of accessories on page 136

FLEXIROL SLIDING GLASS

For sliding glass doors weighing up to 500kg



Flexirol Sliding Glass is a unique system ideally suited to large doors that require high performance as well as an attractive finish. It's an ideal product for hotels, offices, conference centres, shop fronts and showrooms where durability and design are paramount.

Product Information

Product	Glass Thickness	Max. Door Weight
Flexirol Sliding Glass	10mm or 12mm	500kg (100kg per metre of claming)

Product Specification

Component	Description	Short Code
Track	White aluminium track in 2000, 2500, 3000, 4000, 5000 and 6000mm lengths	550/****
	Mill finish track in 2000, 3000, 4000, 5000 and 6000mm lengths	550/****M
Brackets Spaced every 750mm	Face fixed bracket	1A/550
	Suspended soffit fixed ceiling bracket with vertical adjustment	3S/550
Hangers 2 per door	Hanger with mounting block	556S
Glass Profile	Made to measure, contact P C Henderson for more information	FRP02
Guide 2 per door	Guide with mounting block	FRPN/94
Guide Channel	Brass guide channel in 1500 and 3000mm lengths	94/****
	Aluminium guide channel in 1500, 2000, 2500, 3000, 4000 and 6000mm lengths	94X/****
	Aluminium threshold guide channel in 2000, 2500, 3000, 3500, 4000 and 6000mm lengths	94T/****
Stop 2 per door	Track stop	HH3/301

****Replace with length of track or rail for full short code

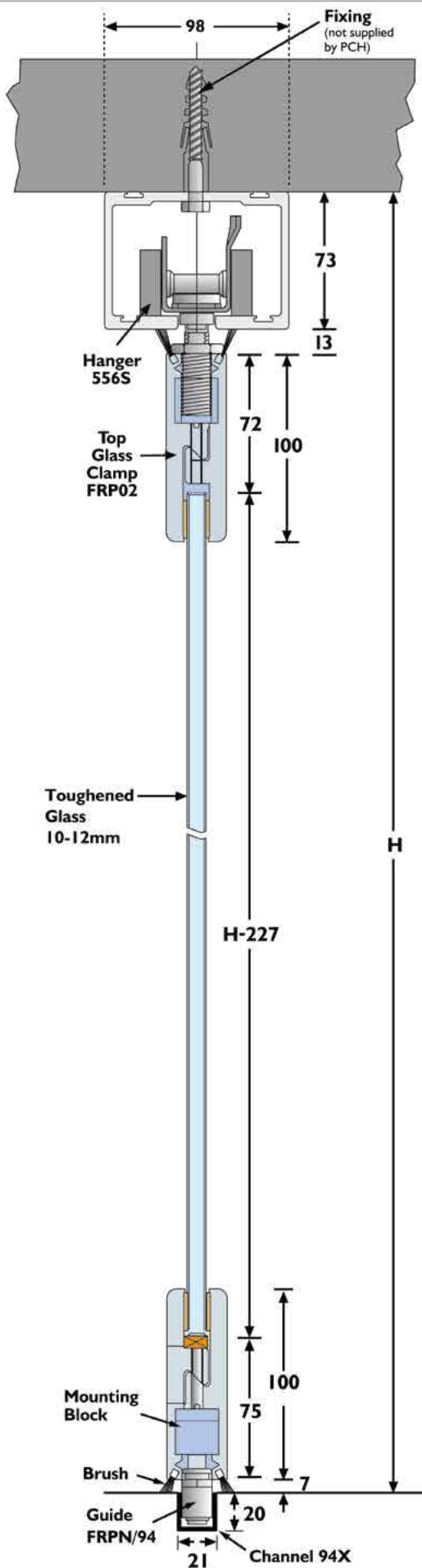

Hardware

Track



550



550M

Brackets



1A/550



3S/550

Hangers



556S

Glass Profile



FRP02

Guide



FRPN/94

Guide Channel



94



94X

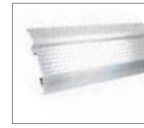

94T

Stop



HH3

Accessories

View our full range of accessories on page 136

STRAIGHT SLIDING ^{290, 301, 301H, 305, 307}

For straight sliding wooden and metal doors for maximum door weights of between 150kg and 2000kg



Our Straight Sliding system for wooden and metal doors contains a wide range of top hung systems for easy movement of anything from light commercial doors up to very heavy and large industrial applications. Seven systems are available for doors weighing up to a maximum of 2000kg. To accommodate different building designs, doors can slide to one or both sides and are also suitable to cover any width of opening.

Product Information

Product	Door Thickness Range	Max. Door Weight
Straight Sliding 290	35 – 48mm	200kg (150kg if using nylon hangers)
Straight Sliding 301	43 – 57mm	400kg
Straight Sliding 301H	43 – 57mm	450kg
Straight Sliding 305	43 – 57mm	700kg
Straight Sliding 307	60 – 70mm	2000kg

Product Specification

Component	Description	290 Short Code	301 Short Code	301H Short Code	305 Short Code	307 Short Code
Track Twice the width of doors	Galvanised steel track in 2000, 2500, 3000, 4000, 5000 and 6000mm lengths (for 307, 5000mm and 6000mm lengths are unavailable)	290/**** 2mm thick	301/**** 2mm thick	301H/**** 3mm thick	305/**** 3mm thick	307/**** 5mm thick
Steel Brackets 900mm max. spacing and at track joints	Face fixed - single	1/290S	1/301S	1/301S	1/305S	1/307S
	Face fixed - single - jointing	1X/290S	1X/301S	1X/301/S	1X/305S	1X/307S
	Face fixed - single - low headroom	9/290S	9/301S	9/301S	-	9/307S
	Face fixed - single - low headroom jointing	9X/290S	9X/301S	9X/301S	-	-
	Face fixed - single - closed end bracket	1/290S**	-	-	-	1/307S**
	Face fixed - double - adjustable for 1 track	-	-	-	-	5/307S
	Face fixed - double - adjustable for both tracks	-	5R/301SADJ	5R/301SADJ	-	-
	Face fixed - double - closed end bracket	-	-	-	-	5/307SC
	Soffit fixed - single	-	3/301S	3/301S	-	3/307S
	Soffit fixed - single - jointing	-	3X/301S	3X/301S	-	3X/307S
	Soffit fixed - single - 'in line'	-	4/301S	4/301S	4/305S	4/307S
	Soffit fixed - single - adjustable	4R/290S	4R/301S	4R/301S	4R/305S	4R/307S
	Soffit fixed - single - adjustable jointing	4RX/290S	-	-	4RX/305S	4RX/307S
	Soffit fixed - single - bolt on (closed)	-	-	-	-	4R/307SC
	Soffit fixed - single - closed end bracket	-	-	-	-	3/307SC
	Soffit fixed - single 'in line' - closed end bracket	-	-	-	-	4/307SC
	Soffit fixed - adjustable track sleeve	-	4RX/301TS	4RX/301TS	-	-
Soffit fixed - double - 'in line'	-	6/301S	6/301S	-	-	
Soffit fixed bracket body (for welding)	4R/290SB	-	-	4R/305SB	4R/307SB	
Aluminium Brackets 900mm max. spacing and a track joints	Face fixed - single	1A/290	1A/301	1A/301	1A/305	-
	Face fixed - single - jointing	1AX/290	1AX/301	1AX/301	1AX/305	-
	Face fixed - single - low headroom	-	-	-	9A/305	-
	Face fixed - single - closed end bracket	-	-	-	1A/305**	-
	Face fixed - single - low head. - closed end	-	-	-	9A/305**	-
	Face fixed - double	5/290	5/301	5/301	-	-
	Face fixed - double adjustable - 1 track	-	-	-	5/305	-
	Soffit fixed - single	3A/290	3A/301	3A/301	3A/305	-
	Soffit fixed - single - jointing	3AX/290	3AX/301	3AX/301	3AX/305	-
	Soffit fixed - single - 'in line'	4A/290	4A/301	4A/301	4A/305	-
Replace ** with 'RC' for right hand closing and 'LC' for left hand closing	Soffit fixed - single - 'in line' jointing	4AX/290	4AX/301	4AX/301	4AX/305	-
	Soffit fixed - single - closed end bracket	-	-	-	3A/305C	-

Product Specification - continued

Component	Description	290 Short Code	301 Short Code	301H Short Code	305 Short Code	307 Short Code
Bracket Endclips	End clip to close open brackets	1A/290EC	1A/301EC	1A/301EC	-	-
Hanger 2 per door /s = steel wheel /n = nylon wheel	Metal door - 2 wheel - standard bolt	56.5K/S	56.5A/S	56.5A/S	-	-
		56.5K/N	56.5A/N	56.5A/N	-	-
	Metal door - 4 wheel - standard bolt	56K/S	56A/S	56A/S	56C/S	56FJ/S
		56K/N	56A/N	56A/N	-	-
	Metal door - 4 wheel - standard bolt - for doors weighing up to 200kg	56K/S200	-	-	-	-
		56K/N200	-	-	-	-
	Metal door - extended bolt	56KX/S	56AX/S	56AX/S	56CX/S	56FJX/S
		56KX/N	56AX/N	56AX/N	-	-
	Metal door - for easy removal of doors	-	56AF/S	56AF/S	-	-
	Wood door - 4 wheel - side plate	53K/S	53A/S	53A/S	53C/S	53FJ/S
		53K/N	53A/N	53A/N	-	-
	Wood door - 4 wheel - side plate - doors weighing up to 200kg	53K/S200	-	-	-	-
	Wood door - 4 wheel - top plate	57K/S	57A/S	57A/S	57C/S	-
		57K/N	57A/N	57A/N	-	-
	Wood door - 4 wheel - top plate - doors weighing up to 200kg	57K/S200	-	-	-	-
Wood door - 4 wheel - angle plate	52K/S	52A/S	52A/S	52C/S	-	
	52K/N	52A/N	52A/N	-	-	
Wood door - 4 wheel - angle plate - doors weighing up to 200kg	52K/S200	-	-	-	-	
Curtain sided vehicle - 4 wheel	56MVS	-	-	-	-	
Guide Channel* Same length as track, replace **** with length for full short code	Galvanised steel channel in 2000, 2500, 3000, 4000 and 6000mm lengths (6000mm unavailable for 89 channel)	89/****	97/****	97/****	97/****	97/****
	Brass channel in 1500 and 3000mm lengths	94/****	-	-	-	-
	Aluminium channel in 1500, 2000, 2500, 3000, 4000 and 6000mm lengths	94X/****	-	-	-	-
	Shallow steel channel in 2000, 2500, 3000 and 4000mm lengths	-	100/****	100/****	100/****	100/****
	Bottom rail in 2000, 2500 and 3000mm lengths	299/****	299/****	299/****	299/****	299/****
	Fixing Lug	97LUG	-	-	-	-
	Channel Coupler	UNICUP	-	-	-	-
Guides	Metal door	104P/89	104P/97	104P/97	104P/97	104P/97
	Metal door - extended	104PX/89	104PX/97	104PX/97	104PX/97	104PX/97
	Wood door - side fixed	105R/89	105R/97	105R/97	105R/97	105R/97
	Wood door - self cleaning	-	102/97	102/97	102/97	102/97
	Wood door - concealed	106R/94	106R/97	106R/97	106R/97	106R/97
	Wood door - end fixed	113R/94	-	-	-	-
	Metal or wood door - stop guide	112	112	112	112	-
	Metal or wood door - ground stay roller	126	126	126	126	-
	Metal or wood door - heavy duty ground stay roller (assembled)	126HD/A	126HD/A	126HD/A	126HD/A	126HD/A
	Metal or wood door - heavy duty ground stay roller	-	126H	126H	126H	126H
	Metal or wood door - heavy duty extended ground stay roller	-	126HL	126HL	126HL	126HL
	Metal or wood door - shoe guide	128	128	128	128	128
Metal or wood door - wall mounted, for single door	31S	31S	31S	31S	-	
Metal or wood door - wall mounted, for double doors	31D	31D	31D	31D	31D	

****Replace with required length for full short code

*All channels supplied with lugs and couplers included except 94 and 94X

STRAIGHT SLIDING CONTINUED

FOR WOOD DOORS

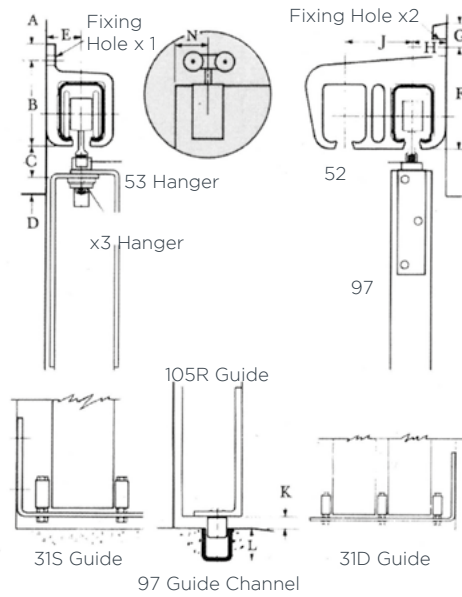

Track	A	B	C	D	E	F	G	H	J	K	L	X1	X2	X3	N
280	7	40	20	12	16					10	25	M5			*
290	13	67	25	13	27	80	20	27	54	10	25	M8	M12	11	48
301/301H	20	97	50	25	35	110	33	39	79	10	38	M12	M16	20	75
305	25	140	50	25	38	155	38	48	92	13	38	M16	M20	20	85
307	24	156	67	38	45	192	26	45	91	13	38	M16	M20	25	115

*Husky 50 (284N) = 110mm *Husky 100 (284) = 120mm

FOR METAL DOORS

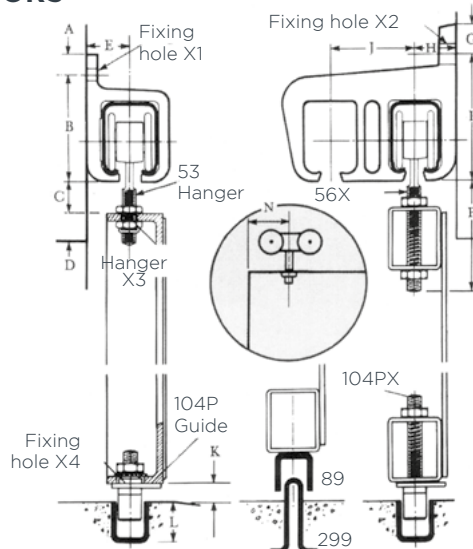

Track	A	B	C	D	E	F	G	H	J	K	L	X1	X2	X3	X4	N	P
280	7	40	20	12	16					10	25	M5		8.4	17	50	
290	13	67	25	13	27	80	20	27	54	10	25	M8	M12	10.5	17	48	1109
301/301H	20	97	50	25	35	110	33	39	79	10	38	M12	M16	17	20	75	140
305	25	140	50	25	38	155	38	48	92	13	38	M16	M20	17	20	85	140
307	24	156	67	38	45	192	26	45	91	13	38	M16	M20	21	20	115	140

Accessories



Rectangle
Flush Pull
(400)
satin, also
available
in stainless
steel



Flush
Pull
(414)



Flush
Pull
(413)



Handle
(463)



Surface
Bolt
380mm
(994)



Offset
Bolt
380mm
(994X)

View our full range of accessories on page 136

Hardware

Track



290

301

301H

305

307

Steel Brackets



1/**S

1X/**S

9/**S

9X/**S



1/**S**

5/307S

5R/301SADJ

5/307SC

3/**S

3X/**S

4/**S

4R/**S

4RX/**S

Aluminium Brackets



4R/307SC

3/307SC

4/307SC

4RX/301TS

6/301S

4R/**SB

1A/**

1AX/**

9A/305

Hangers



1A/305**

9A/305**

5/**

3A/**

3AX/**

56.5K/S

56.5A/S

56.5K/N

56.5A/N



56K/S

56A/S

56C/S

56FJ/S

56K/N

56A/N

56K/S200

56K/N200

56KX/S



56AX/S

56CX/S

56FJX/S

56KX/N

56AX/N

56AF/S

53K/S

53A/S

53C/S



53FJ/S

53K/N

53A/N

53K/S200

57K/S

57A/S

57C/S

57K/N

57A/N



57K/S200

52K/S

52A/S

52A/S

52C/S

52K/N

52A/N

52K/S200

56MVS

Guide Channel

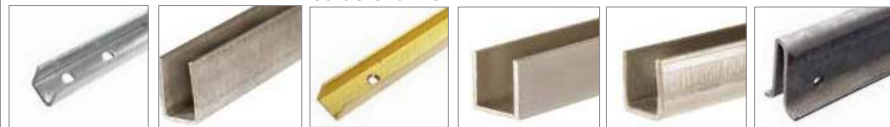

89

97

94

94X

100

299

Guides



97LUG

UNICUP

104P



104PX

105R

106R

113R

112

126

128

31S

31D

STERLING

For bottom rolling wooden and metal doors weighing up to 8000kg



The Sterling range of bottom rolling systems is ideal for heavy commercial and industrial applications such as warehouses, agricultural buildings and aircraft hangars. The product is particularly suitable where the supporting structure or lintel is insufficient for the weight of the door or headroom is limited. Five systems are available in total, catering for wooden doors weighing up to a maximum of 2000kg and metal doors up to a maximum weight of 8000kg. The product is suitable for single or multiple lines of track and the top guide channel may be soffit fixed or face fixed.

Product Information

Product	Door Material	Door Thickness Range	Max. Door Weight
Sterling 350	Wood or Metal	44 - 54mm	350kg
Sterling 800	Wood or Metal	54 - 63mm	800kg
Sterling 2000	Wood or Metal	58 - 70mm (metal) or 70 - 100mm (wood)	2000kg
Sterling 3600	Metal	152mm minimum	3600kg
Sterling 8000	Metal	152mm minimum	8000kg

Product Specification

Component	Description	350 Short Code	800 Short Code	2000 Short Code	3600 Short Code	8000 Short Code
Top Guide Channel	Galvanised steel track in 2000, 2500 and 3000mm lengths. 13 Channel is only available in 2000 and 3000mm lengths.	99/****	99/****	13/****	Not by P C Henderson	
Brackets Fix at 900mm centres (max.)	Face fixed	31	31	-	Not by P C Henderson	
	Face fixed adjustable	-	-	1/13		
	Soffit fixed and jointing	-	-	2/13		
	Double face fixed jointing	35X	35X	5/13		
	Double face fixed	35	35	-		
Top Guide Rollers 2 per doors for all except 3600 and 8000 systems which require 4 per door	Metal door - 7000mm max. height	-	-	-	104S/125	104S/125
	Metal door - 12500mm max. height	104/99	104/99	-	104S/175	104S/175
	Metal door - 20000mm max. height	-	-	104/13	104S/200	104S/200
	Wooden door - saddle fixing	53/99	53/99	53/13	-	-
Bottom Rollers 2 per door. Zinc plated and maintenance free, sealed for life roller bearing	Metal door for standard rail (wheel and bolt on only)	1SU	3SU	4SJU	-	-
	Metal door for V tread rail (wheel and bolt on only)	1SV	3SV	4SJV	-	-
	Metal door for square tread rail (wheel and bolt on only)	1SL	3SL	4SJL	-	-
	Metal door - standard roller	1S	3S	4SJ	3600IR*	8000IR*
	Metal door - geared	-	-	-	3600OR*	8000OR*
	Wooden door	2	3	4J	-	-
Bottom Rail	Galvanised steel in 2000, 2500, 3000 and 4000mm lengths	298/****	298/****	298/****	-	-
	Heavy steel section in 2700mm lengths	-	-	-	297/2700	297/2700
Stop	Wall mounted stops with double rubber buffer	107	107	107	107	107

****Replace with length of track or rail for full short code

*These components require additional parts based on individual project requirements. Please contact P C Henderson with specification details.

FOR WOOD DOORS

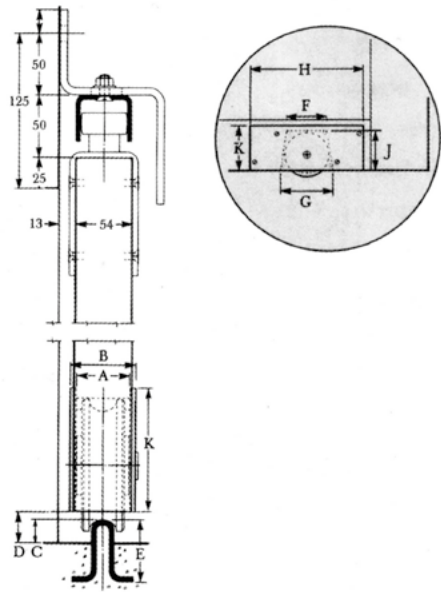

Dimensions

Track	A	B	C	D	E	F	G	H	J	K
350	44	54	20	25	50	115	135	305	95	102
800	51	63	20	30	50	135	175	381	130	152

FOR METAL DOORS

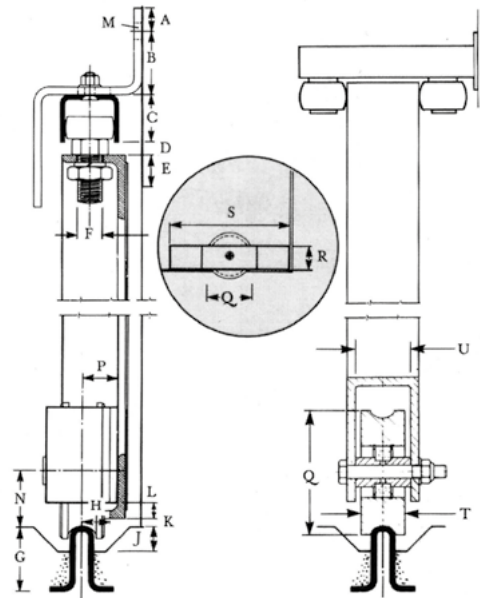

Dimensions

Track	A	B	C	D	E	F	G	H	J	K	L	M	N	P	Q	R	S	T	U
350	20	50	38	10	25	21	50	22	20	6	13	12	44	29	110	75	305	40	50
800	20	50	38	10	25	2	50	22	20	6	13	12	62	32	146	75	381	40	50
2000	32	35	85	25	30	26	50	25	20	10	12	16	85	32	197	102	457	45	56
3600				20	127	32	65	44							286			105	128
8000				20	203	32	65	44							436			105	128

STERLING CONTINUED

Hardware

Top Guide Channel



99



13

Brackets



31



1/13



2/13



35X



5/13



35

Top Guide Rollers



104/99



104/13



53/99



53/13



104S

Bottom Rollers



1SU



1SV



1SL

Bottom Rollers



1S



2



3SU



3SV



3SL



3S



3



4SJV

Bottom Rollers



4SJV



4SJV



4SJV



4J



3600



8000

Bottom Rail



298



297

Stop



107

Accessories



Surface Bolt
380mm (**994**)



Offset Bolt
380mm (**994X**)

View our full range of accessories on page 136

OVERHEAD RUNWAY

Selection of track, curves and brackets which can be used together to make a variety of overhead runway systems



P C Henderson's tracks, curves and brackets can be used together with a choice of specially adapted hangers to make a variety of overhead runway systems. Suitable for a wide variety of applications including curtains, cable carriers, safety runways in factories, warehouses, dairies, commercial/public buildings and vehicles.

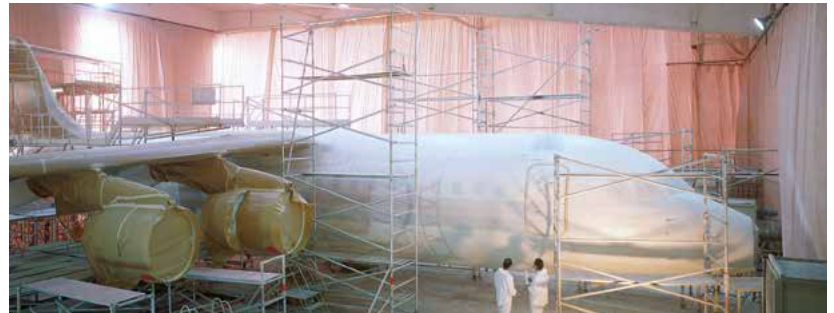

Product Specification

Component	Description	280 Short Code	290 Short Code	301 Short Code	301H Short Code	305 Short Code
Track	Galvanised steel track in 2000, 2500, 3000, 4000, 5000 and 6000mm lengths	280/****	290/****	301/****	301H/****	305/****
Curves	Track curves	280TC	600K	600B	600BH	600D
Brackets	Face fixed, single	281	1A/290	1A/301	1A/301	1A/305
	Soffit fixed, single		3A/290	3A/301	3A/301	3A/305
	Soffit fixed, single 'in line'		4A/290	4A/301	4A/301	4A/305
	Soffit fixed, single, bolt on		4R/290S	4R/301S	4R/301S	4R/305S
Hangers	For sliding wooden doors (2 wheels)	285	-	-	-	-
	For sliding wooden doors (4 wheels)	-	57K/N	-	-	57C/S
	For sliding metal doors (2 wheels)	285N	56.5K/S	56.5A/S	56.5A/S	-
	For sliding metal doors (4 wheels)	-	56K/N	56A/S	56A/S	56C/S
	For folding wooden doors	283	-	-	-	-
	For hanging curtains	288	-	-	-	-
Stops	Clip stop	601H	-	-	-	-
	Track Stop	287	HH3/290/SS	HH3/301/SS	HH3/301/SS	-

Hardware

Track					Curves			
280	290	301	301H	305	280TC	600K	600B	600BH
Curves					Brackets			
600D	1A	3A	4A	4R	285	285N	283	288
Hangers					Stops			
288H	57	56	56.5	58	601H	287	HH3	



Folding Doors



Our range of folding door hardware caters for doors weighing up to 150kg, for interior and exterior applications, endfold and centrefold mechanisms as well having the ability to hold virtually any number of doors in a variety of combinations.

Whether it be for a bi-folding cupboard, a versatile room divider or a stylish exterior system to open up a home to the outside world – P C Henderson has a folding door solution for every project.

When used internally, as room dividers and partitions, folding doors are the perfect way to create flexible living and working environments allowing an entire room to be opened up at ease. When used externally, folding doors can help to bring the outside in, making the most of natural light and external views.

Range Overview

- Over 14 different systems
- Catering for doors weighing up to 150kg
- Suitable for wooden or metal doors
- Interior and exterior applications

www.pchenderson.com

BIFOLD



Watch our Installation Video
pchenderson.com/bifold-installation



For folding wardrobe and cupboard doors weighing up to 14kg



The Bifold range of folding door hardware offers a stable, silent and smooth-opening folding system for cupboard and wardrobe doors that can complement any room. Designed for wooden and wood framed doors, the Bifold system can support a maximum door weight of 14kg and door thickness of between 18-35mm. A range of kits are available to cater for a maximum opening width of 2134mm. A fittings kit is available for when an additional door is required.

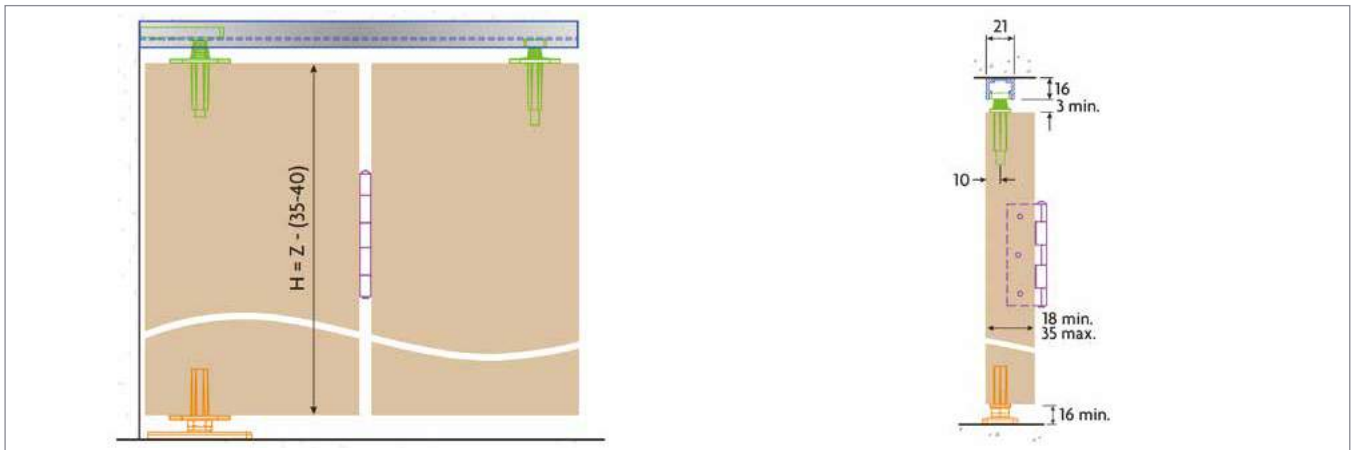

Product Information

Kit Order Code	No. of Doors*	Track Length	Max. Door Height	Max. Door Width	Door Thickness Range	Max. Door Weight
B10/2	2	1067mm	2400mm	530mm	18 - 35mm	14kg
B15/4	4 (2+2)	1524mm	2400mm	530mm	18 - 35mm	14kg
B20/4	4 (2+2)	2134mm	2400mm	530mm	18 - 35mm	14kg
BF2	Fittings kit for when an additional door is required (maximum 4 doors to either side 4+4)					

*Door refers to number of individual panels e.g. picture shows 4 doors (2 + 2).

Kit Contents

Component	Short Code
Track (x 1)	310/****
Top Pivot Socket (x 1 for 2 doors; x 2 for 4 doors)	311
Bottom Pivot (x1 for 2 doors; x 2 for 4 doors)	312
Top Pivot (x 1 for 2 doors; x 2 for 4 doors)	313
Bottom Pivot (x 1 for 2 doors; x 2 for 4 doors)	314
Nylon Guide (x 1 for 2 doors; x 2 for 4 doors)	315
Bumper (x 1 for 2 doors; x 2 for 4 doors)	316
Aligner (x 1 for 2 doors; x 2 for 4 doors)	319
Hinges (x 3 for 2 doors; x 6 for 4 doors)	282S
Adjustable Bottom Pivot Assembly (x 1 for 2 doors; x 2 for 4 doors)	289B

**** Replace by length of track for full short code

Accessories



1 Door Fittings
Kit (BF2)

View
our full
range of
accessories
on page
136

ROOMFLEX

Minimalistic folding door solution with no bottom channel for doors weighing up to 35kg and 50kg



Roomflex is an innovative, internal folding door system, designed to create and enhance flexible living environments. Unlike other internal folding door systems, Roomflex has been designed to completely eliminate the need for a bottom channel, allowing for an aesthetically pleasing, seamless walkway from room to room.

Homeowners can combine both open and broken plan living by neatly storing the doors to one side when the spaces are opened for entertaining or socialising. When closed, the smaller rooms can be used for independent activities.

Kits can be combined together to create various door configurations (see configuration plan).

Product Information

Product	Kit Order Code	Door Configuration	Max. Door Height	Max. Door Width	Door Thickness Range	Max. Door Weight
Roomflex 35kg	RFK1	2	3000mm	926mm	35 - 44mm	35kg
	RFK2	3	3000mm	926mm	35 - 44mm	35kg
	RFK3	4 (3 + 1)	3000mm	926mm	35 - 44mm	35kg
	RFK4	Swing door	3000mm	926mm	35 - 44mm	35kg
Roomflex 50kg	RF50K1	2	3000mm	926mm	35 - 44mm	50kg
	RF50K2	3	3000mm	926mm	35 - 44mm	50kg
	RF50K3	4 (3 + 1)	3000mm	926mm	35 - 44mm	50kg
	RFK4	Swing door	3000mm	926mm	35 - 44mm	50kg

Track Specification - track must be purchased in addition to kit

Short Code	Description
180/****	Anodised aluminium track in 2000, 2500, 3000, 3500, 4000, 5000 and 6000mm lengths

**** Replace by length of track for full short code

Kit Contents

Product	Component
RFK1 and RF50K1	Pivot Set (x 1)
	Hinge Handle Set (x 1)
	End Hanger Set (x 1)
RFK2 and RF50K2	110mm Flush Bolt (x 1) (FB110S)
	Pivot Set (x 1)
	Offset Handle Hinge Set (x 1)
	Intermediate Hanger Set (x 1)
RFK3 and RF50K3	110mm Flush Bolt (x 2) (FB110S)
	Pivot Set (x 2)
	Offset Handle Hinge Set (x 1)
RFK4	Intermediate Hanger Set (x 1)
	110mm Flush Bolt (x 2) (FB110S)
	Pivot Set (x 1)

Accessories



Frame Perimeter Seal (AQ21B) brown, also available in white



Door Perimeter Seal (AG63B) brown, also available in white



Track Seal in Black (BS10B)



Magnetic Door Stop for Pivot Door (FANTOM/S)

View our full range of accessories on page 136

CONFIGURATION

RFK1

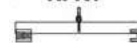

RFK2

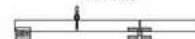

RFK3

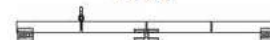

RFK2 + RFK1



RFK2 + RFK2



RFK1 + RFK4



HUSKY FOLDING

For folding interior doors weighing up to 25kg and 40kg



Husky folding door hardware provides a simple and flexible solution for both light and medium weight residential folding partitions. Designed for wooden, wood framed and composite doors, its concealed fixings and robust floor gear allow the partitions to be neatly stacked to one or both sides. The Husky Folding 25 can support doors weighing up to 25kg and 610mm wide without a floor channel, and the Husky Folding 40 can support doors weighing up to 40kg and 762mm wide, with a floor channel included.

The track can be cut to length and extra pivots are required for two doors folding each way (see note underneath product information table).

Product Information

Product	Kit Order Code	No. of Doors*	Track Length	Max. Door Height	Max. Door Width	Door Thickness Range	Max. Door Weight	
Husky 25	HF25/12	2	1234mm	2400mm	610mm	20 – 44mm	25kg	
	HF25/24	4**	2458mm	2400mm	610mm	20 – 44mm	25kg	
	HF2/25	Fittings kit to be used when an additional 2 doors are required						25kg
	HF4/25	Fittings kit to be used when an additional 4 doors are required						25kg
Husky 40	HF40/15	2	1538mm	2700mm	762mm	20 – 44mm	40kg	
	HF40/30	4**	3066mm	2700mm	762mm	20 – 44mm	40kg	
	HF2/40	Fittings Kit to be used when an additional 2 doors are required						40kg
	HF4/40	Fittings Kit to be used when an additional 4 doors are required						40kg

**Extra pivots required for 4 doors folding (2+2) (289B & 289T)

*Door refers to number of individual panels e.g. picture shows 4 doors (2 + 2), maximum number of doors is 4 to either side (4+4)

Kit Contents

Product	Component	Short Code
Husky 25	Steel Track (x 1)	280/****
	Top Pivot for fixing onto end panel (x 1)	289T
	Bottom Pivot for fixing onto end panel (x 1)	289B
	Four Wheeled Adjustable Nylon Hangers (x 1 for 2 doors; x 2 for 4 doors)	283N
	Hinges (x 3 for 2 doors; x 9 for 4 doors)	282/S
Husky 40	Steel Track (x 1)	280/****
	Top Pivot for fixing onto end panel (x 1)	289T
	Bottom Pivot for fixing onto end panel (x 1)	289B
	Guide Channel (x 1)	94X/****
	Needle Roller Bearing Hangers (x 1 for 2 doors; x 2 for 4 doors)	283
	Roller Guide (x 1 for 2 doors; x 2 for 4 doors)	106HF/94
	Hinges (x 3 for 2 doors; x 9 for 4 doors)	282/S

**** Replace by length of track for full short code



Watch our Installation Video
pchenderson.com/husky-folding-installation

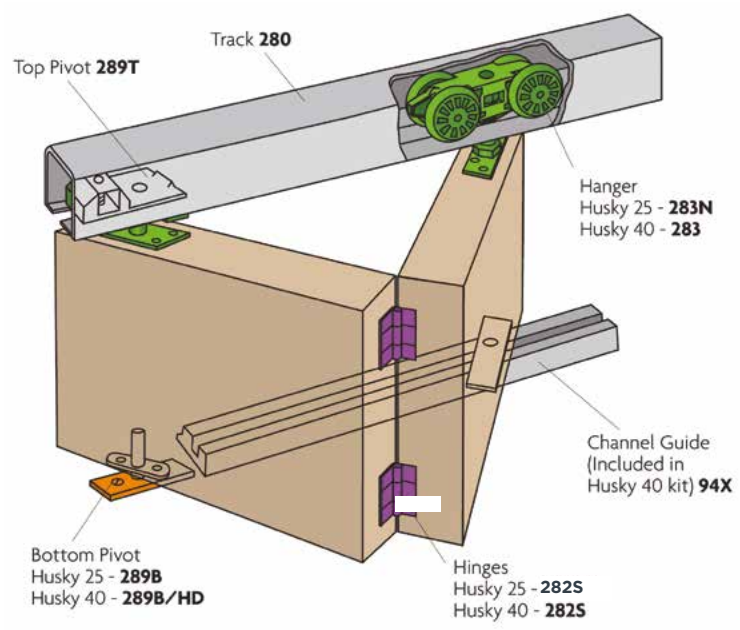

Husky 25

Husky 40

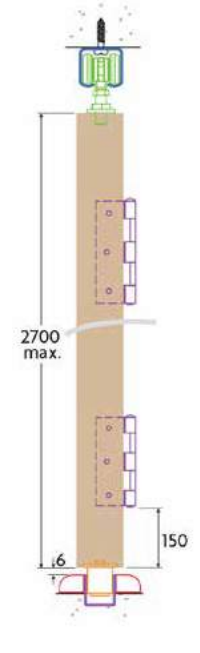
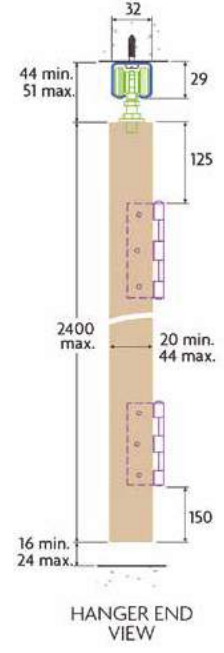
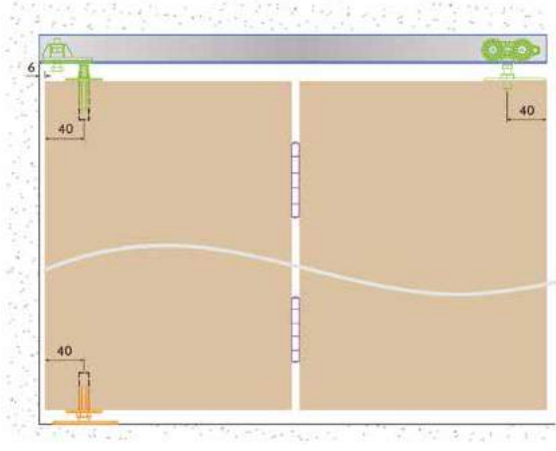
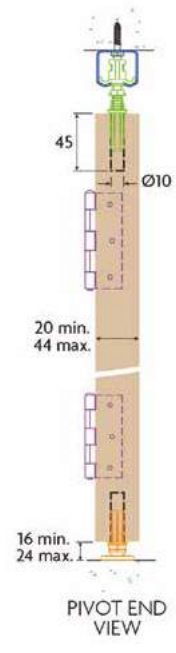

Accessories



Rectangle
Flush Pull
(125/S) satin,
also available in
chrome

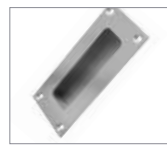

Rectangle
Flush Pull
(400) satin, also
available in stainless
steel



2 Door Fittings
Kit for Husky 25
(HF2/25)



2 Door Fittings
Kit for Husky 40
(HF2/40)



4 Door Fittings
Kit for Husky 25
(HF4/25)



4 Door Fittings
Kit for Husky 40
(HF4/40)

View our full range of accessories on page 136

PACER ENDFOLD

For interior folding doors weighing up to 35kg and 65kg



Pacer Endfold is a top hung, medium weight partition door system - perfect for internal residential and commercial applications requiring end folding doors. The system offers both two-wheeled and four-wheeled hangers to cover a wide range of applications. Panels can be hung to the left or right of an opening as well as being hung as floating units.

An application using the four-wheeled hanger, with even numbers of panels folding left and right, meeting in the centre of an opening, requires an offset hanger (21BO/4).

Product Information

Product	Max. Door Height	Max. Door Width	Door Thickness Range	Max. Door Weight
Pacer Endfold 35	2700mm	900mm	35 - 44mm	35kg
Pacer Endfold 65	2700mm	900mm	35 - 44mm	65kg

Product Specification

Component	Door Configuration	35kg	65kg
Track	Aluminium mill finish track in 2000, 2500, 3000, 3500, 4000, 5000 and 6000mm lengths	600/****	600/****
	Anodised aluminium track in 2000, 2500, 3000, 3500, 4000, 5000 and 6000mm lengths	600/****AN	600/****AN
Brackets	Face fixed bracket (fixed at 500mm intervals)	1B	1B
	Joining bracket	1BX	1BX
Hangers <small>Offset hanger required in applications with an even number of doors folding left and right meeting in the centre of an opening.</small>	Two-wheeled end hanger	21B	-
	Four-wheeled end hanger	-	21B/4
	Four-wheeled offset end hanger	-	21BO/4
Pivot <small>For door widths of between 35 - 44mm. Allows doors to be of equal width.</small>	Pivot	21B/P	21B/P
Guide <small>1 for every 2 door leaves</small>	Nylon end guide roller	21N/94	21N/94
Guide Channel	Brass guide channel in 1500 and 3000mm lengths	94/****	94/****
	Aluminium guide channel in 1500, 2000, 2500, 3000, 4000 and 6000mm lengths	94X/****	94X/****
	Aluminium threshold guide channel in 2000, 2500, 3000, 3500, 4000 and 6000mm lengths	94T/****	94T/****
	Polypropylene guide channel in 2000, 2500, 3000, 3500, 4000, 5000 and 6000mm lengths	94P/****	94P/****
Hinges	Butt hinge - 100 x 55mm	403/2	403/2

**** Replace by length of track for full short code

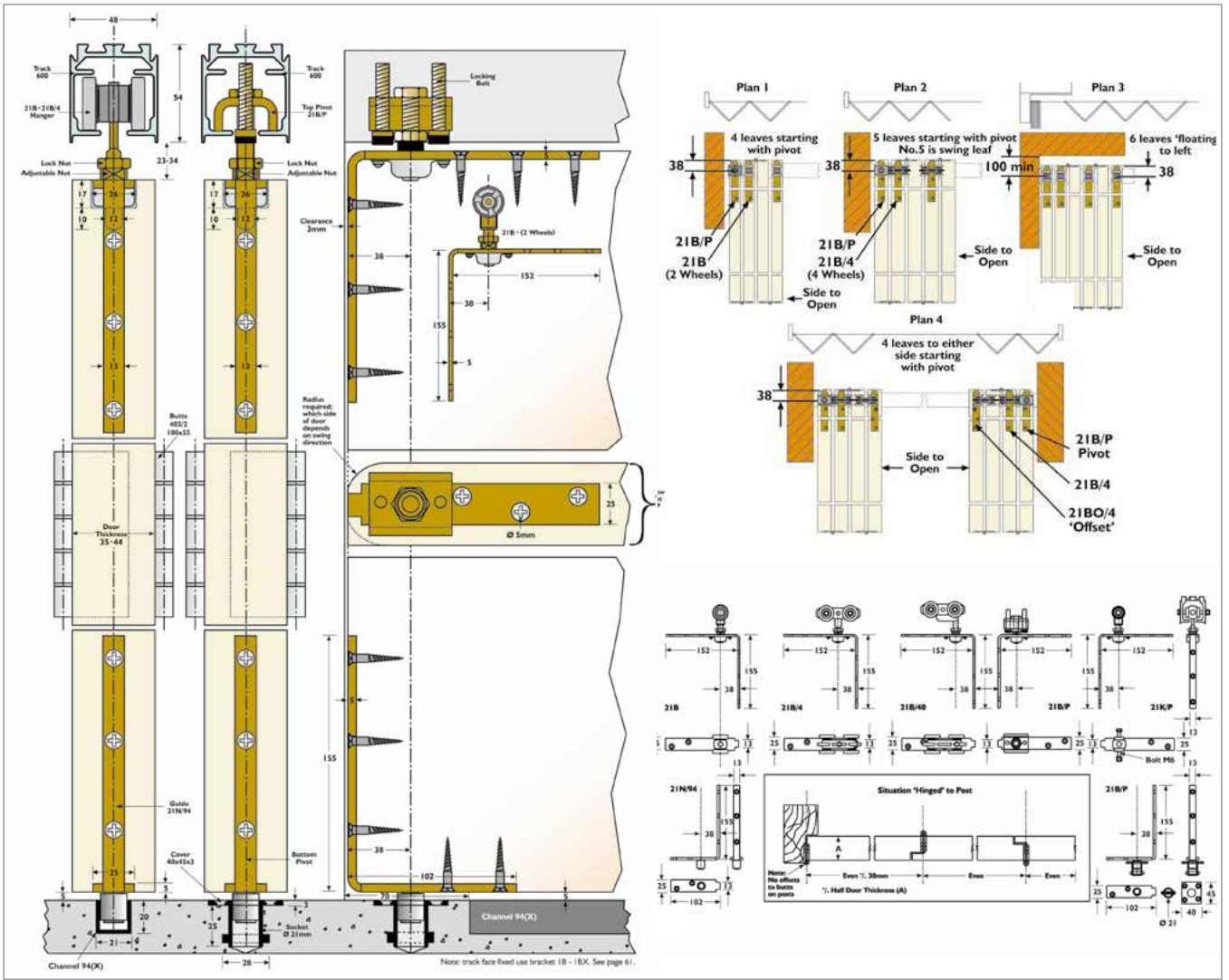

Hardware

Track



600



600AN

Brackets



1B



1BX

Hangers



21B



21B/4



21BO/4

Pivot



21B/P

Guide



21N/94

Guide Channel



94



94X



94T

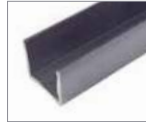

94P

Hinge



403/2

Accessories



Rectangle Flush Pull (400) SAA, also available in stainless steel



Flush Bolt (333) Satin anodised aluminium



Flush Bolt (FB110S) Non Locking



Magnetic Door Stop (FANTOM/S) for swing doors

View our full range of accessories on page 136

TANGENT FOLDING

For top hung folding wooden or metal doors weighing up to 35kg, 55kg or 70kg



Tangent Folding is a range of robust, top-hung hardware systems for wooden or metal doors weighing up to 35kg, 55kg or 70kg. Ideal for commercial or light industrial application, the system caters for panelled, flush or glazed doors. Doors can fold to one or both sides of the opening or can be stacked behind a reveal if required. The system covers any width of opening allowing any number of folding doors to be used. Panels should be in units of four, six or eight and can be hinged to post or free floating.

For applications where an odd number of doors is required, a swinging access door can be incorporated into a panel which is hinged to post. Alternatively an access door can be independently hinged to post.

When the system is fitted externally a canopy is recommended (not supplied by P C Henderson).

Product Information

Product	Max. Door Height	Max. Door Width	Door Thickness Range	Max. Door Weight
Tangent 290	2400mm	900mm	35 - 50mm	35kg
Tangent 301	3300mm	900mm	45 - 55mm	55kg
Tangent 301H	3600mm	900mm	45 - 55mm	70kg

Product Specification

Component	Door Configuration	Tangent 290 Short Code	Tangent 301 Short Code	Tangent 301H Short Code
Track Equal to width of opening (extra if doors slide further)	Galvanised steel track in 2000, 2500, 3000, 4000, 5000 and 6000mm lengths.	290/****	301/****	301H/****
Brackets Fix every 900mm max. and at track joints. Fix additional brackets where doors stack	Face fixed bracket	1A/290	1A/301	1A/301
	Soffit fixed bracket	3A/290	3A/301	3A/301
Hangers 1 for every 2 doors leaves	Intermediate hanger	62K	62A	62A
	End hanger	63K	63A	63A
Hinges 3 in height. Extend to 4 when doors exceed 3000mm high.	Aluminium alloy backflap hinge	65	65	65
Guides 1 for every 2 door leaves	Intermediate guide	67/89	67/97	67/97
	Intermediate guide spindle	67/89SP	67/97SP	67/97SP
	End guide	68/89	68/97	68/97
Channels Same length as track	Galvanised steel channel in 2000, 2500, 3000, 4000 and 6000mm lengths (89 not available in 6000mm)	89/****	97/****	97/****

**** Replace by length of track for full short code

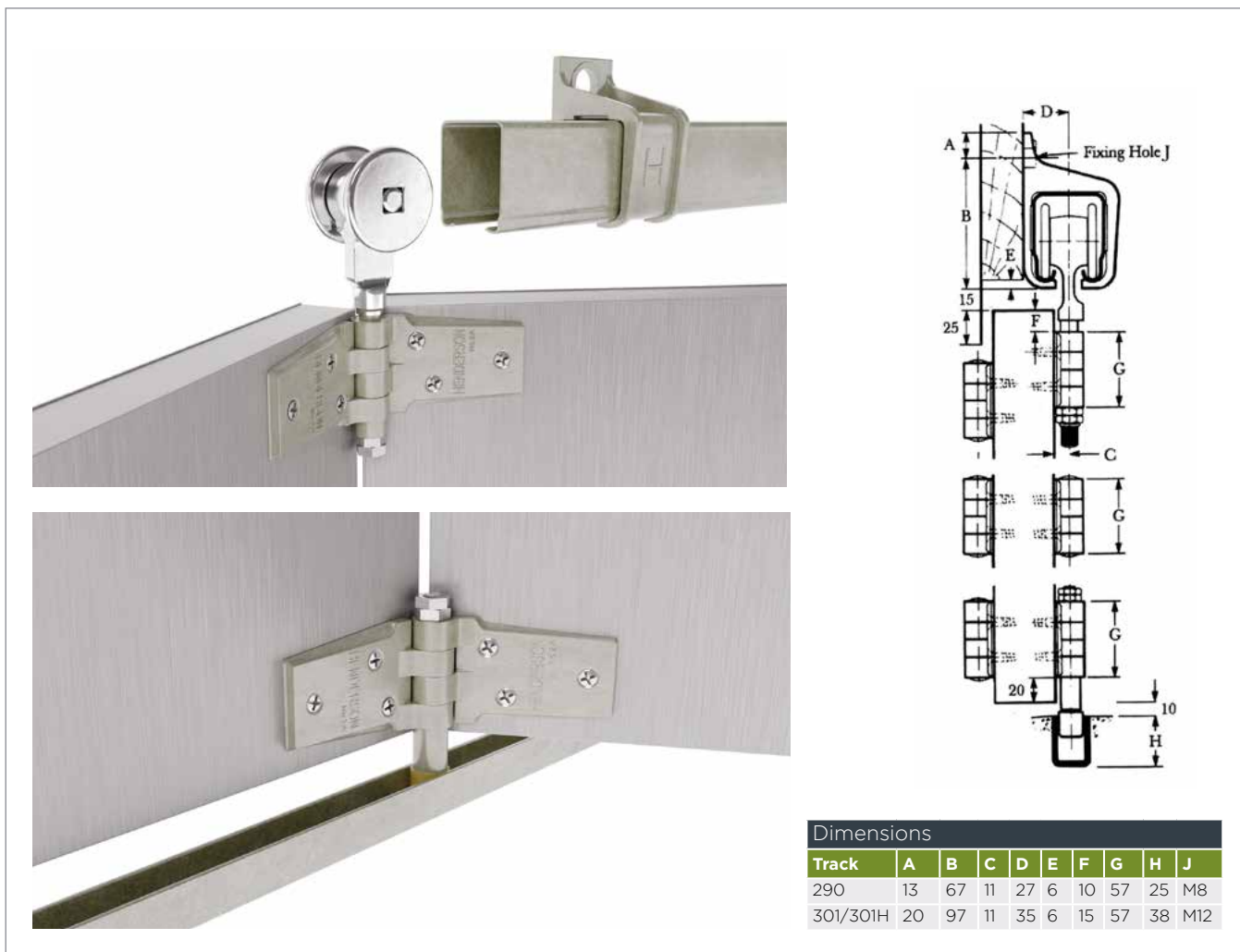

Hardware

Track



290



301



301H

Brackets



1A



3A

Hangers



62K



63K



62A

Hanger



63A

Hinge



65

Guides



67

67/**SP



67/**SP

68



68

Channels



89



97

Accessories



Rectangle Flush Pull (**400**) SAA, also available in stainless steel



Rectangle Flush Pull (**414**) Aluminium, heavy duty



Cast Iron Bow Handle 159 x 46mm (**463**)



Galvanised Steel Shoot Bolt 380mm (**994**)



Fantom Magnetic Door Stop (**FANTOM/S**) for swing doors

View our full range of accessories on page 136

PACER CENTREFOLD

For top hung centre folding interior partition doors weighing up to 35kg and 75kg



Pacer Centrefold is a top hung system for centre folding wooden partition doors. Doors are hung centrally and can fold to one or both sides. For applications hinged to the jamb, 3.5, 5.5 or 7.5 doors can be used with the half door hinged to the jamb. For best operation of floating units 5, 7 or 9 doors should be used. Any access doors should be hinged separately to the jamb.

Product Information

Product	Max. Door Height	Max. Door Width	Door Thickness Range	Max. Door Weight
Pacer Centrefold 35	2700mm	900mm	35 - 44mm	35kg
Pacer Centrefold 75	2700mm	900mm	35 - 44mm	75kg

Product Specification

Component	Description	35kg	75kg
Track	Aluminium mill finish track available in 2000, 2500, 3000, 3500, 4000, 5000 and 6000mm lengths	600/****	600/****
	Anodised aluminium track in 2000, 2500, 3000, 3500, 4000, 5000, 6000mm lengths	600/****AN	600/****AN
Brackets	Face fixed bracket (fixed at 500mm intervals)	1B	1B
	Jointing bracket	1BX	1BX
Hangers	Two-wheeled end hanger (max. door weight of 35kg)	61B	-
	Four-wheeled end hanger (max. door weight of 75kg)	-	61B/4
Guides	Nylon guide roller	106N/94	106N/94
Hinges	Butt Hinge - 100 x 55mm	403/2	403/2
Guide Channel	Brass guide channel available in 1500 and 3000mm lengths	94/****	94/****
	Aluminium guide channel available in 1500, 2000, 2500, 3000, 4000 and 6000mm lengths	94X/****	94X/****
	Aluminium threshold guide channel available in 2000, 2500, 3000, 3500, 4000 and 6000mm lengths	94T/****	94T/****

**** Replace by length of track for full short code

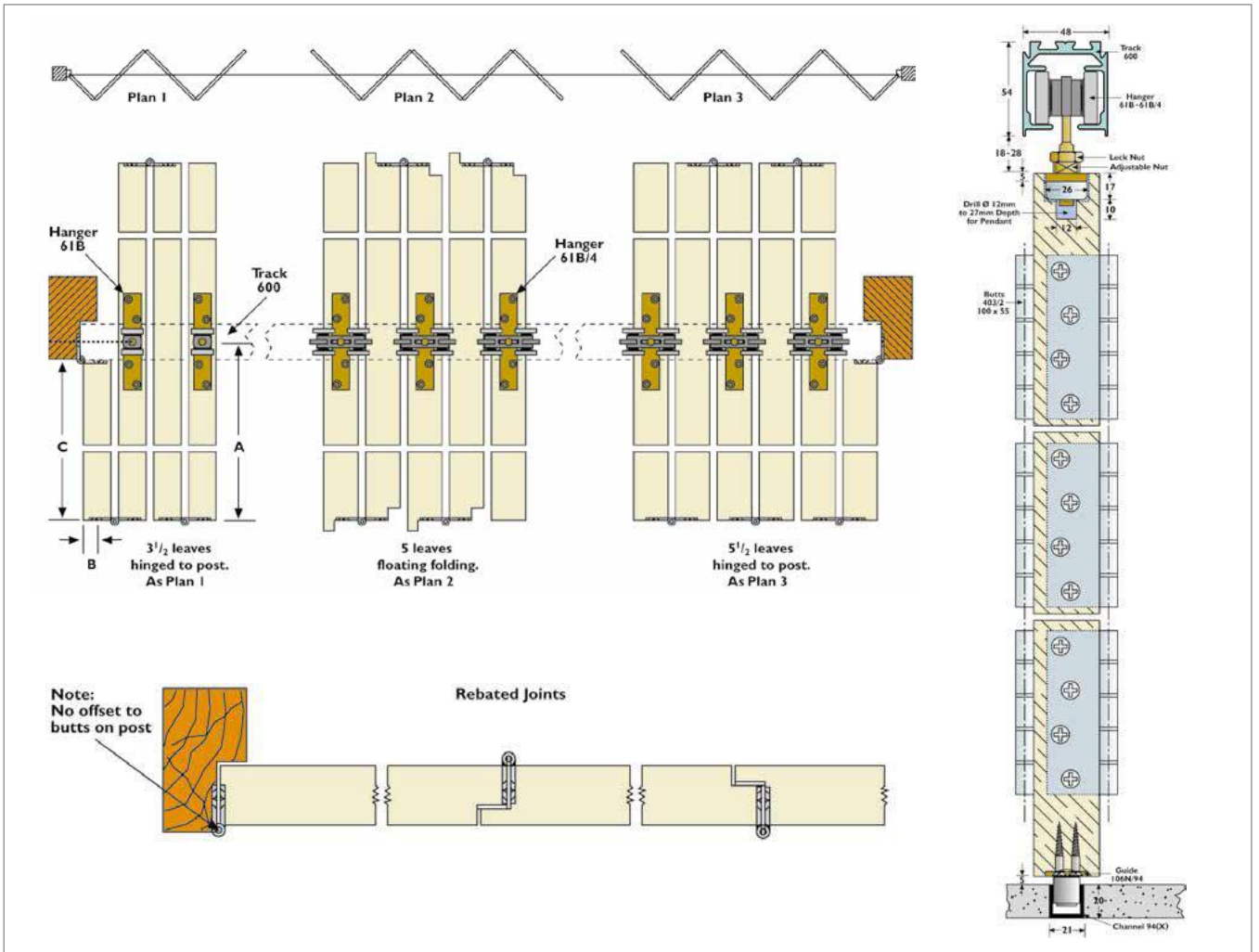

Hardware

Track



600



600AN

Brackets



1B



1BX



61B



61B/4

Guides



106N/94

Hinge



403/2

Guide Channel



94

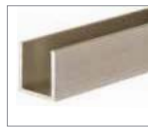

94X

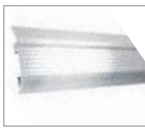

94T

Accessories



Rectangle Flush Pull (400) SAA



Rectangle Flush Pull (414) aluminium, heavy duty



Flush Bolt (333) Satin anodised aluminium



Flush Bolt (FB110S) Non Locking



Fantom Magnetic Door Stop (FANTOM/S) for swing doors

View our full range of accessories on page 136

SOLTAIRE ENDFOLD

For metal or wooden end folding doors weighing up to 45kg and 75kg



Soltaire Endfold is the ideal solution for partition doors in residential or commercial applications, catering for folding doors weighing up to 45kg or 75kg. Manufactured from marine grade 316 stainless steel, the system is extremely durable and hard wearing, utilising components from our popular Securefold and Soltaire products. The system is particularly suitable for partitions where all doors are of equal width.

The folding unit is pivoted in the track and off the floor - allowing adjustment on all doors. Doors can fold to one or both sides of the opening, as well as being able to cater for multiple combinations to cover any width of opening. End folding units of up to eight doors can be pivoted to each side of the opening.

Product Information

Product	Kit Order Code	Door Configuration	Max. Door Height	Max. Door Width	Door Thickness Range	Max. Door Weight
Soltaire Endfold 45kg	SEF145	2 Door Base Kit	3000mm	900mm	35 - 44mm	45kg
	SEF245	2 Door Add-On Kit	3000mm	900mm	35 - 44mm	45kg
	SF5S	1 Door Add-On Kit	3300mm	900mm	35 - 44mm	45kg
	SEFP	Swing Door	3300mm	900mm	35 - 44mm	45kg
Soltaire Endfold 75kg	SEF175	2 Door Base Kit	3300mm	900mm	35 - 44mm	75kg
	SEF275	2 Door Add-On Kit	3300mm	900mm	35 - 44mm	75kg
	SF5S	1 Door Add-On Kit	3300mm	900mm	35 - 44mm	75kg
	SEFP	Swing Door	3300mm	900mm	35 - 44mm	75kg

Track and Channel Specification - Track and channel must be purchased in addition to kit

45kg System	75kg System	Description
180/****	250/****	Anodised aluminium track in 2000, 2500, 3000, 3500, 4000, 5000 and 6000mm lengths
94P/****	94P/****	Polypropylene channel in black in 2000, 2500, 3000, 3500, 4000, 5000 and 6000mm lengths
94SC/****	94SC/****	Support channel for polypropylene channel in 2000, 2500, 3000, 3500, 4000, 5000, 6000mm

**** Replace by length of track for full short code

Kit Contents

Product	Component
SEF145 and SEF175	Pivot Set (x1)
	Hinge Handle Set (x1)
	End Hanger and Guide Set (x1)
	110mm Flush Bolt (x1) (FB110S)
SEF245 and SEF275	Midset Hinge Set (x1)
	Hinge Handle Set (x 1)
	End Hanger and Guide Set (x1)
	110mm Flush Bolt (x1) (FB110S)
SF5S	Midset Hinge Set (x1)
SEFP	Pivot Set (x1)

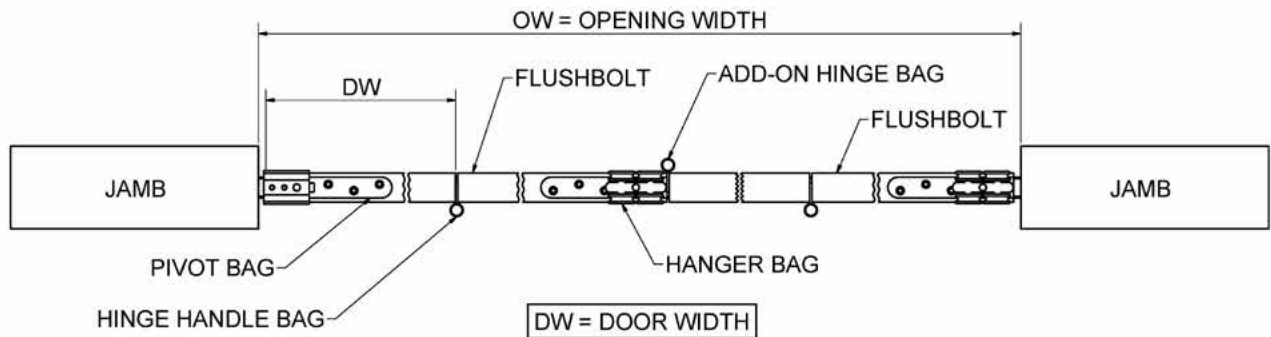
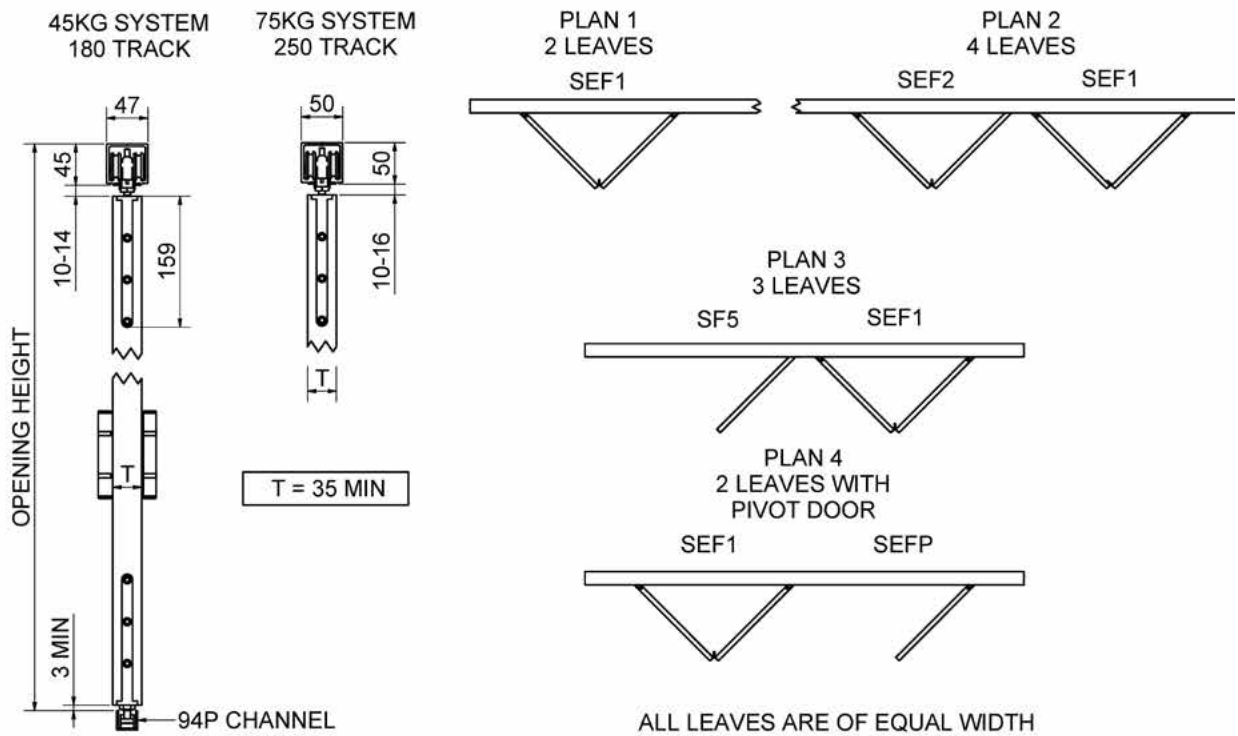

Accessories



Rectangle
Flush Pull
(400) SAA,
also available in
stainless steel



Door
Perimeter Seal
(AQ63B) brown,
also available in
white



Frame
Perimeter Seal
(AQ21B) brown,
also available in
white



Track Seal
(BS10B) black



Fantom Magnetic
Door Stop
(FANTOM/S) for
swing doors

View our
full range of
accessories
on page 136

SOLTAIRE CENTREFOLD

For metal or wooden centre folding doors weighing up to 45kg and 75kg



Catering for folding doors weighing up to 45kg and 75kg, Soltaire Centrefold is the ideal solution for partition doors in residential and commercial applications. Manufactured from 316 marine grade stainless steel, the system is extremely durable and hard wearing, utilising components from our popular Securefold and Soltaire products. The system is also particularly suitable for applications where increased height is a requirement.

As a centre folding system, the weight of the doors is supported centrally under the track. Panels can be floating or fold to one or both sides of the opening as well as being able to cater for multiple combinations of folding panels to cover any width of opening. For best operation - one, three, five or seven panels should be used.

Product Information

Product	Kit Order Code	Door Configuration	Max. Door Height	Max. Door Width	Door Thickness Range	Max. Door Weight
Soltaire Centrefold 45kg	SCF145	1.5 Door Base Kit	3000mm	900mm	35 - 44mm	45kg
	SCF245	2 Door Add-On Kit	3000mm	900mm	35 - 44mm	45kg
	SF5S	1 Door Add-On Kit	3300mm	900mm	35 - 44mm	45kg
Soltaire Centrefold 75kg	SCF175	1.5 Door Base Kit	3300mm	900mm	35 - 44mm	75kg
	SCF275	2 Door Add-On Kit	3300mm	900mm	35 - 44mm	75kg
	SF5S	1 Door Add-On Kit	3300mm	900mm	35 - 44mm	75kg

Track and Channel Specification - Track must be purchased in addition to kit

45kg System	75kg System	Description
180/****	250/****	Anodised aluminium track in 2000, 2500, 3000, 3500, 4000, 5000 and 6000mm lengths
94P/****	94P/****	Polypropylene channel in black in 200, 2500, 3000, 3500, 4000, 5000 and 6000mm lengths
94SC/****	94SC/****	Support channel for polypropylene channel in 2000, 2500, 3000, 3500, 4000, 5000, 6000mm

**** Replace by length of track for full short code

Kit Contents

Product	Component
SCF145 and SCF175	Pivot Set (x1)
	Hinge Handle Set (x1)
	Centrefold Hanger and Guide Set (x1)
	110mm Flushbolt (x1) (FB110S)
SCF245 and SCF275	Midset Hinge Set (x1)
	Hinge Handle Set (x1)
	Centrefold Hanger and Guide Set (x1)
	110mm Flush Bolt (x1) (FB110S)
SF5S	Hinge Set

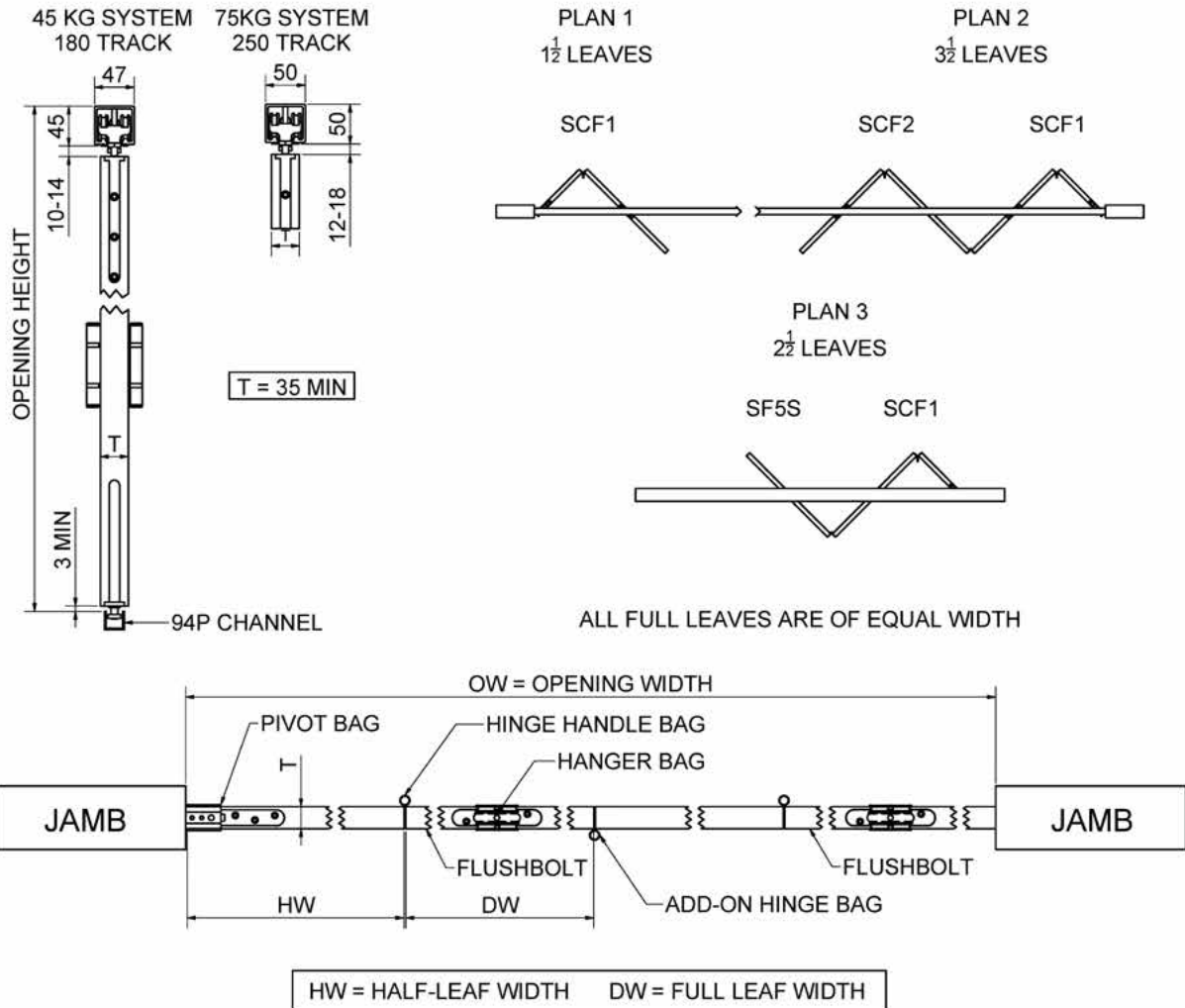

Accessories



Flush Pull
(400) SAA,
also available in
stainless steel



Door
Perimeter Seal
(AQ63B) brown,
also available in
white



Frame
Perimeter Seal
(AQ21B) brown,
also available in
white



Track Seal
(BS10B) black



Fantom Magnetic
Door Stop
(FANTOM/S) for
swing doors

View our
full range of
accessories
on page 136

SECUREFOLD BOTTOM ROLLING

Bottom rolling system for folding wooden doors weighing up to 80kg



Our latest addition to the Securefold family allows for huge flexibility in terms of the type of applications it can cater for. Utilising bottom rolling technology, the product carries the weight of the doors at the bottom of the system eliminating the need for a large upper beam. This allows doors to be installed into virtually any space without the need for major structural building support. It also frees up design space allowing for a minimalistic look. Typical applications include orangeries, conservatories, out buildings and extensions.

Our new and improved Twinbolt locking system is also now available as an alternative to flush bolts. Top and bottom throw rods are operated by one simple turn of a handle to engage two points of locking, the system can then be locked from the inside.

Product Information

Product	Max. Door Height	Max. Door Width	Door Thickness Range	Max. Door Weight
Securefold Bottom Rolling	3000mm	1000mm	56 - 68mm	80kg

Product Specification

Component	Description	Standard Mortice	Square Mortice	Non Mortice
Track	Anodised aluminium track in 3000, 4000 and 6000mm lengths		242/****	
Pivot	Pivot assembly	SFBR1*	SFMBR1*	SFWBR1*
Roller*	End roller set kit	SFBR2*	SFMBR2*	SFWBR2*
	Intermediate roller set kit	SFBR4*	SFMBR4*	SFWBR4*
Hinge	Hinge handle set		SF3*	
	Hinge set - offset outward opening		SF7*	
	Intermediate hinge for doors above 2200mm		SF9*	
Meeting Kit*	Meeting kit	SFBR8*	SFMBR8*	SFWBR8*
Channel	Polypropylene guide channel available in 2000, 2500, 3000, 3500, 4000, 5000 and 6000mm lengths		94P/****	
	Anodised aluminium support channel available in 2000, 2500, 3000, 3500, 4000, 5000 and 6000mm lengths		94SC/****	
Seals	Door perimeter seal in brown		AQ63B or AQ63W	
	Frame perimeter seal in brown or white		AQ21B or AQ21W	
	Track seal in black		BS10B	
Flushbolts	Flushbolt in 190, 450 and 600mm lengths (non lockable)		SF190* or SF450* or SF600*	
	Flushbolt in 190, 450 and 600mm lengths (lockable) (600mm only available in satin or black)		SF190L* or SF450L* or SF600L*	
Handle	Handle for Securefold		SF10*	

**** Replace by length of track for full short code

* Replace with first letter of required colour for full short code - gold, black, chrome or satin

Twinbolt Specification - Alternative locking system to flush bolts

Component	Description	Standard Mortice	Square Mortice	Non Mortice
Twinbolt	Twin locking system for Securefold	TB/SFBR	TB/SFMBR	TB/SFBR
Twinbolt Handle	Handle for Twinbolt		TWINHAN/S	
Routing Cover Strip	Available in brown, black or white		TBCS/BR or TBCS/BL or TBCS/WH	

Door Configurations and Hardware Quantities

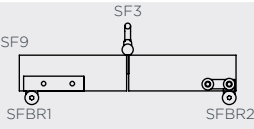
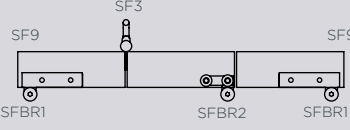
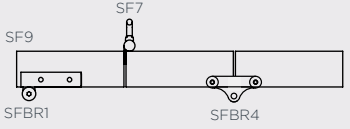
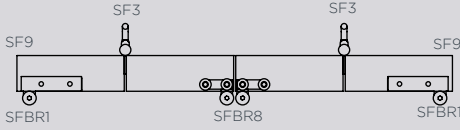
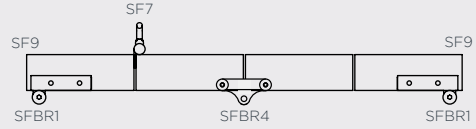
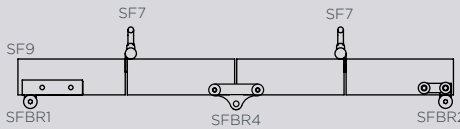
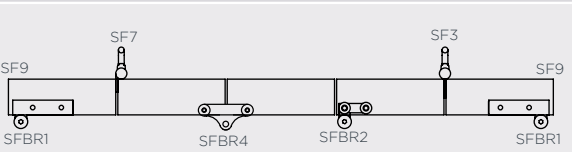
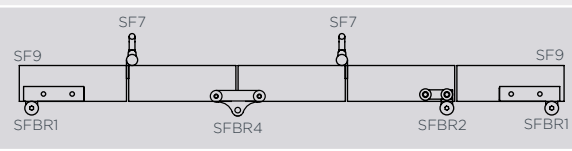
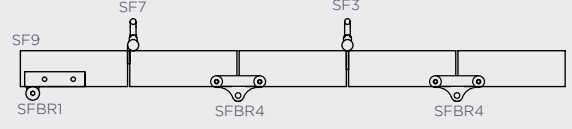
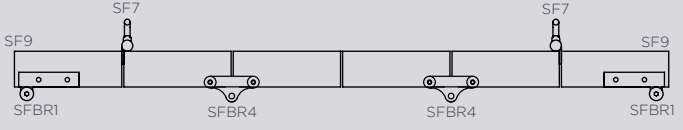
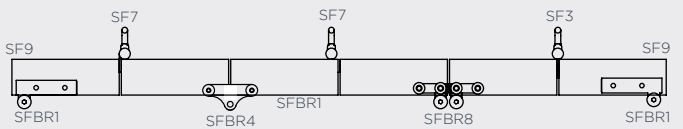
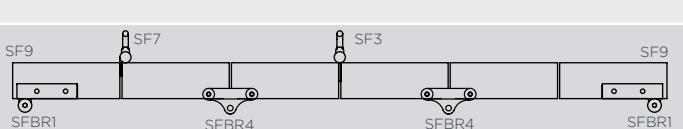
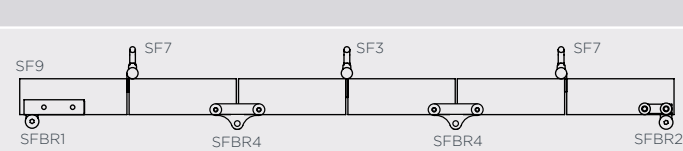
Door Configuration		Hardware
2 Leaf		SFBR1 x 1 SF3 x 1 SFBR2 x 1 SF9 x 1 SF Flushbolt x 2
2 + 1 Leaf		SFBR1 X 2 SF3 X 1 SFBR2 X 1 SF9 X 2 SF Flushbolt x 2
3 Leaf		SFBR1 x 1 SF7 x 1 SFBR4 x 1 SF9 x 1 SF Flushbolt x 2
2 + 2 Leaf		SFBR1 x 2 SF3 x 2 SFBR8 x 1 SF9 x 2 SF Flushbolt x 4
3 + 1 Leaf		SFBR1 x 2 SF7 x 1 SFBR4 x 1 SF9 x 2 SF Flushbolt x 4
4 Leaf		SFBR1 x 1 SF7 x 2 SFBR4 x 1 SFBR2 x 1 SF9 x 1 SF Flushbolt x 4
3 + 2 Leaf		SFBR1 x 2 SF7 x 1 SF3 x 1 SFBR2 x 1 SFBR4 x 1 SF9 x 2 SF Flushbolt x 4
4 + 1 Leaf		SFBR1 x 2 SF7 x 2 SFBR4 x 1 SFBR2 x 1 SF9 x 2 SF Flushbolt x 4
5 Leaf		SFBR1 x 1 SF7 x 1 SF3 x 1 SFBR4 x 2 SF9 x 1 SF Flushbolt x 4
3 + 3 Leaf		SFBR1 x 2 SF7 x 2 SFBR4 x 2 SF9 x 2 SF Flushbolt x 6
4 + 2 Leaf		SFBR1 x 2 SF7 x 2 SFBR4 x 1 SF3 x 1 SFBR8 x 1 SF9 x 2 SF Flushbolt x 6
5 + 1 Leaf		SFBR1 x 2 SF7 x 1 SF3 x 1 SFBR4 x 2 SF9 x 2 SF Flushbolt x 6
6 Leaf		SFBR1 x 1 SF7 x 2 SFBR4 x 2 SF3 x 1 SFBR2 x 1 SF9 x 1 SF Flushbolt x 6

SECUREFOLD BOTTOM ROLLING CONTINUED

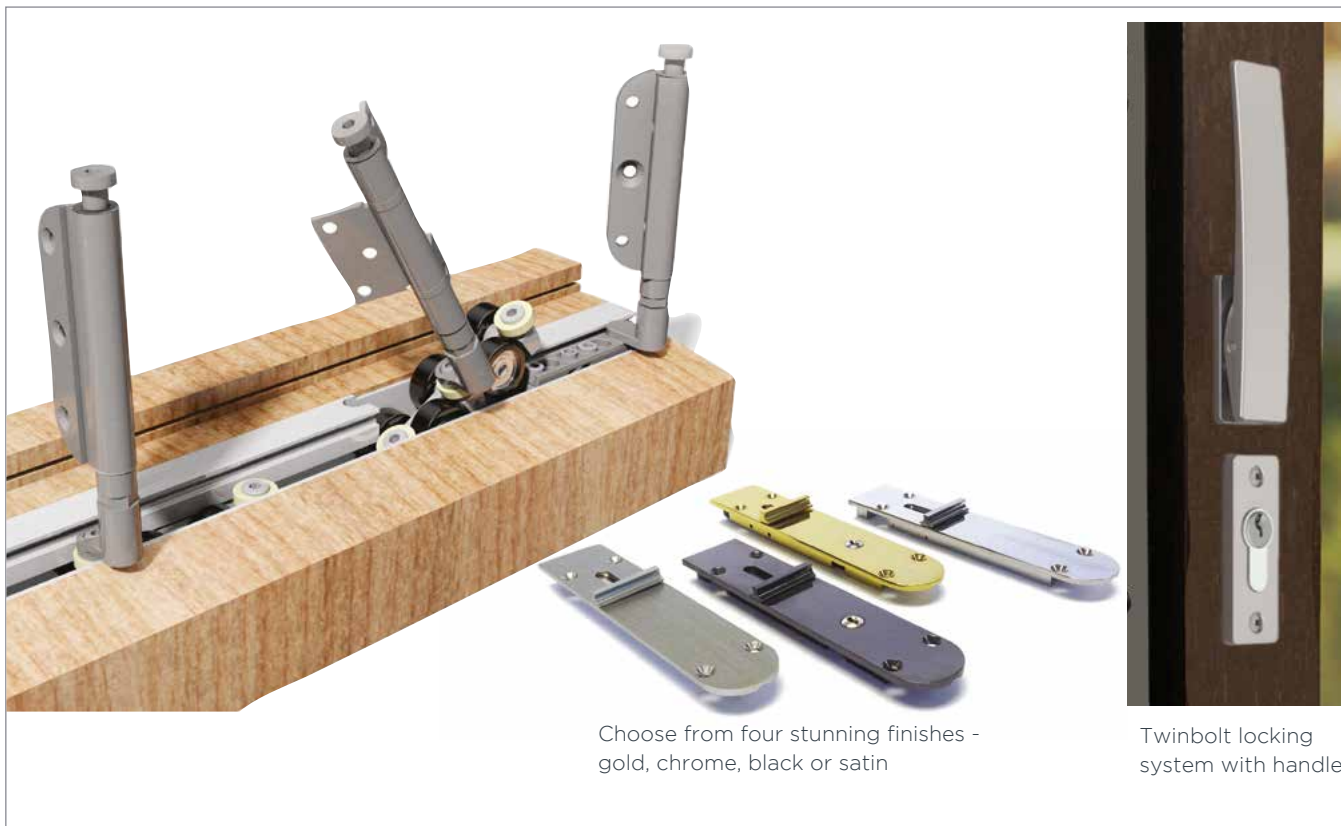

Choose from four stunning finishes - gold, chrome, black or satin

Twinbolt locking system with handle

Hardware

Track



242

Pivot



SFBR1

Rollers



SFBR2



SFBR4

Hinges



SF3



SF7



SF9

Meeting Kit



SFBR8

Channels

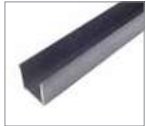

94P



94SC

Seals



AQ63



AQ21



BS10B

Flushbolts



SF190



SF450



SF600

Handle



SF10

Twinbolt



TB/SFBR

Twinbolt Handle



TWINHAN/S

Twinbolt Routing Strip



TBCS/BR

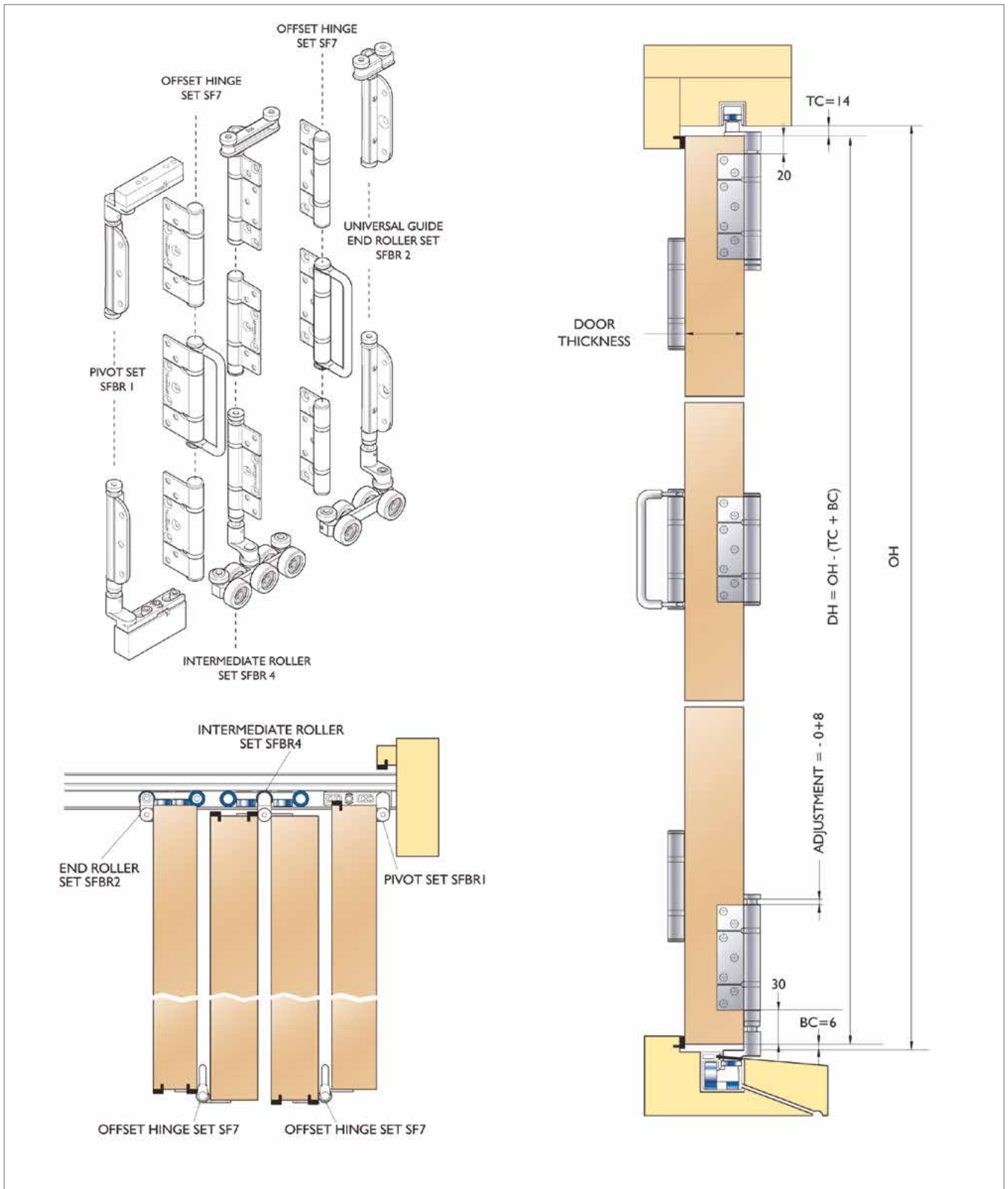

Accessories



Magnet Set
(**MAG/***) for
between doors



Magnet Set
(**SWMAG/***)
for swing door



Router Tool
(**ROUTER**) for
routing detail of
flush bolts

View our full range
of accessories on
page 136

* Replace with first letter of required colour for full short code (satin, chrome, gold or black)

COUNCIL CENTREFOLD

For centre folding wooden partition doors weighing up to 35kg, 55kg, 70kg or 80kg



Council Centrefold offers a quality top hung system designed for centre folding wooden partition doors. Four systems are available for doors weighing up to 80kg each. Folding units of up to seven full doors and one half door can be hinged to the post. When using floating units, configurations must consist of five, seven or nine full doors and have a minimum clearance of 2mm between them.

Council Centrefold offers the opportunity to house access doors in the form of a swing door or a wicket door contained within one of the doors. It is essential that all doors are of equal width. It is also worth noting that door leaves should be constructed to provide secure fixing for hanger, hinges and guides and can be flush, panelled or glazed.

Product Information

Product	Max. Door Height	Max. Door Width	Door Thickness Range	Max. Door Weight
Council Centrefold 290	2700mm	1000mm	35 - 44mm	35kg
Council Centrefold 301	3300mm	1000mm	44 - 57mm	55kg
Council Centrefold 301H	3600mm	1000mm	44 - 57mm	70kg
Council Centrefold 305	4500mm	1000mm	44 - 57mm	80kg

Product Specification

Component	Description	Council Centrefold 290	Council Centrefold 301	Council Centrefold 301H	Council Centrefold 305
Track Equal to opening width	Galvanised steel track in 2000, 2500, 3000, 4000, 5000 and 6000mm lengths	290/****	301/****	301H/****	305/****
Brackets Fix every 900mm max. and at track joints. Fix extra bracket where doors stack.	Soffit fixed bracket	3A/290	3A/301	3A/301	3A/305
Hangers 1 every 2 panels	Centre folding hanger, steel wheels	61K/S	61A/S	61A/S	61C/S
	Centre folding hanger, nylon wheels	61K/N	61A/N	61A/N	-
Hinges 3 in height. Increase to 4 for doors over 3000mm high	Butt hinge	403/2	403/2	403/2	403/3
Guides 1 every 2 panels	Centre folding guide	106R/94	106R/94	106R/94	106R/94
Guide Channel	Brass guide channel available in 1500 and 3000mm lengths	94/****	94/****	94/****	94/****
	Aluminium guide channel in 1500, 2000, 2500, 3000, 4000 and 6000mm lengths.	94X/****	94X/****	94X/****	94X/****

**** Replace by length of track for full short code

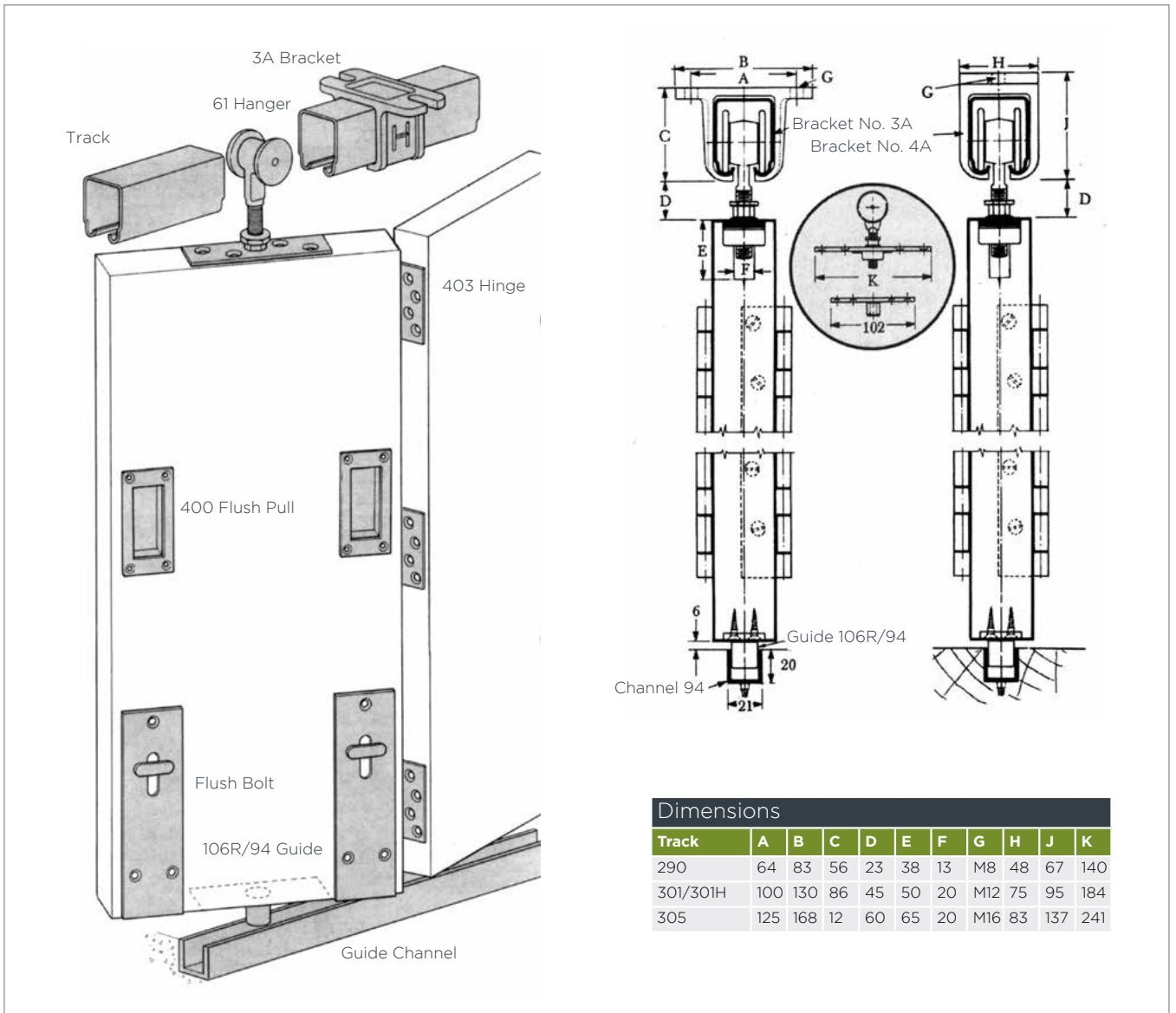

Hardware



Accessories

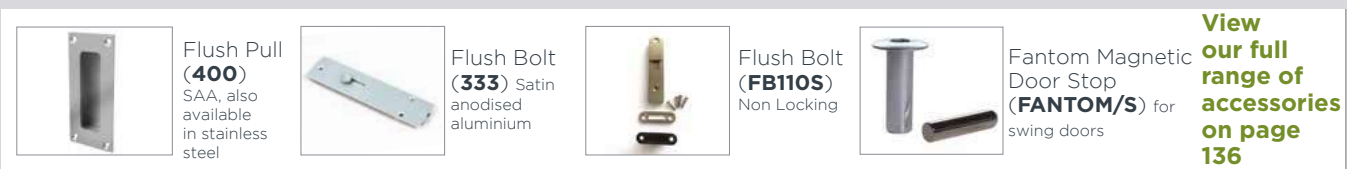

View our full range of accessories on page 136

COUNCIL ENDFOLD

For end folding wooden partition doors weighing up to 35kg, 55kg, 70kg and 80kg



Council Endfold is a quality range of top hung, folding partition systems for wooden doors.

Four systems are available for doors weighing up to 80kg each. Ideally suited for residential and commercial partitions, Council Endfold can cover any width of opening with any number of folding doors.

Folding units of up to eight doors can be hinged to post or be floating units. Doors must consist of four, six or eight doors, with a minimum clearance of 2mm between each one.

Any access doors used within the system should be a swing door or a wicket door housed within one of the main doors. No more than 6 doors should be hinged together and can be hinged to jam or floating.

A swinging pass door is obtained by using a 3 or 5 door unit up to 3000mm high or an independently hung door.

Product Information

Product	Max. Door Height	Max. Door Width	Door Thickness Range	Max. Door Weight
Council Endfold 290	2700mm	900mm	35 - 44mm	35kg
Council Endfold 301	3300mm	900mm	44 - 57mm	55kg
Council Endfold 301H	3600mm	900mm	44 - 57mm	70kg
Council Endfold 305	4500mm	900mm	44 - 57mm	80kg

Product Specification

Component	Description	290	301	301H	305
Track Equal to opening width	Galvanised steel track in 2000, 2500, 3000, 4000, 5000 and 6000mm lengths	290/****	301/****	301H/****	305/****
Brackets Fix every 900mm max. and at track joints. Fix extra bracket where doors stack.	Soffit fixed bracket	3A/290	3A/301	3A/301	3A/305
Hangers every 2 leaves (+end leaf of floating unit only)	End folding hanger, steel wheels	21K/S	21A/S	21A/S	21C/S
	End folding hanger, nylon wheels	21K/N	-	-	-
	End folding hanger for swing leaf	21K/4N	21A/4S	21A/4S	21C/4S
	End folding hanger, steel wheels (4)	21K/4S	-	-	-
	End folding pivot set	21K/P	21A/P	21A/P	21A/P
Hinges 3 in height (increase to 4 for doors over 3000mm high).	Butt hinge	403/2	403/2	403/2	403/3
Guides 1 every 2 doors (plus end door of floating unit only)	End folding guide	21KR/94	21R/94	21R/94	21R/94
Guide Channel	Brass guide channel available in 1500 and 3000mm lengths	94/****	94/****	94/****	94/****
	Aluminium guide channel in 1500, 2000, 2500, 3000, 4000 and 6000mm lengths	94X/****	94X/****	94X/****	94X/****

**** Replace by length of track for full short code

SECTION DETAILS

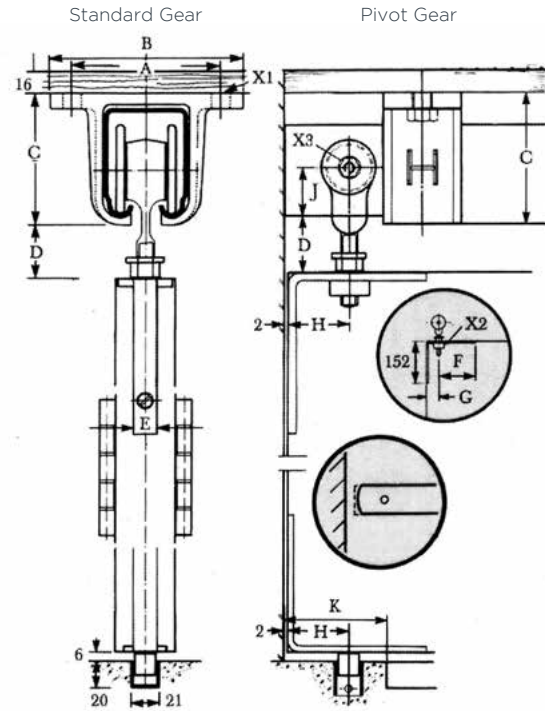
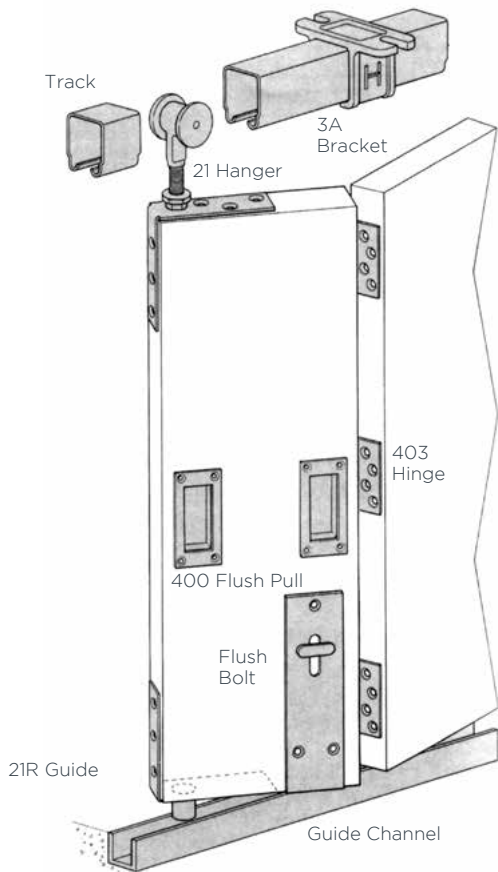

Dimensions

Track	A	B	C	D	E	F	G	H	J	K	X1	X2	X3
290	64	83	56	20	13	114	38	38	20	70	M8	13	M6
301/301H	100	130	86	45	18	133	45	45	35	75	M12	20	M8
305	125	168	121	60	18	133	45				M16	29	

Hardware

Track

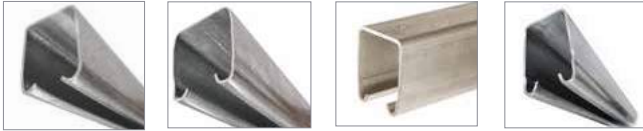

290

301

301H

305

Brackets



3A

Hangers



21K/S

21A/S

21C/S

Hangers



21K/N

21K/4N

21A/4S

21C/4S

21K/4S

21K/P

21A/P

Hinge



403

Guides



21KR/94

21R/94

Guide Channel

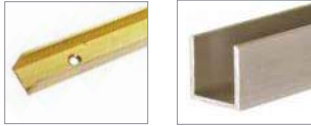

94

94X

Accessories



Rectangle Flush Pull (400) SAA, also available in stainless steel



Flush Bolt (454) Satin anodised aluminium



Flush Bolt (FB110S) Non locking



Fantom Magnetic Door Stop (FANTOM/S) for swing doors

View our full range of accessories on page 136

FLEXIROL ENDFOLD

For heavy weight end folding partition doors weighing up to 125kg



Flexirol Endfold has been developed for commercial applications requiring heavy weight, top hung folding doors. Designed as an end folding system, the product can cater for interior wooden doors with panels being able to be hung to the left or right of an opening or alternatively hung as a floating unit.

Product Information

Product	Door Material	Max. Door Height	Max. Door Width	Door Thickness Range	Max. Door Weight
Flexirol Endfold	Wood	4500mm	1200mm	43 - 57mm	125kg

Product Specification

Component	Description	Short Code
Track	White aluminium track in 2000, 2500, 3000, 4000, 5000 and 6000mm lengths	550/****
	Aluminium mill finish track in 2000, 3000, 4000, 5000 and 6000mm lengths	550/****M
Brackets	Face fixed bracket (fixed at 500mm intervals)	1A/550
	Soffit fixed adjustable, suspended ceiling bracket	3S/550
Hangers <small>*With stainless steel strap bolt.</small>	Angle plate fixing hanger	556/21
Pivots	Top and bottom pivot set	21/550P
Guides	Brass end guide roller	21R/94
Hinges	100 x 75mm butt hinge	403/3
Guide Channel	Brass guide channel in 1500 and 3000mm lengths	94/****
	Aluminium guide channel in 1500, 2000, 2500, 3000, 4000 and 6000mm lengths	94X/****
	Aluminium threshold guide channel in 2000, 2500, 3000, 3500, 4000 and 6000mm lengths	94T/****
	Polypropylene guide channel in 2000, 2500, 3000, 3500, 4000, 5000 and 6000mm lengths	94P/****
	Anodised aluminium support channel in 2000, 2500, 3000, 3500, 4000, 5000 and 6000mm lengths	94SC/****

**** Replace by length of track for full short code

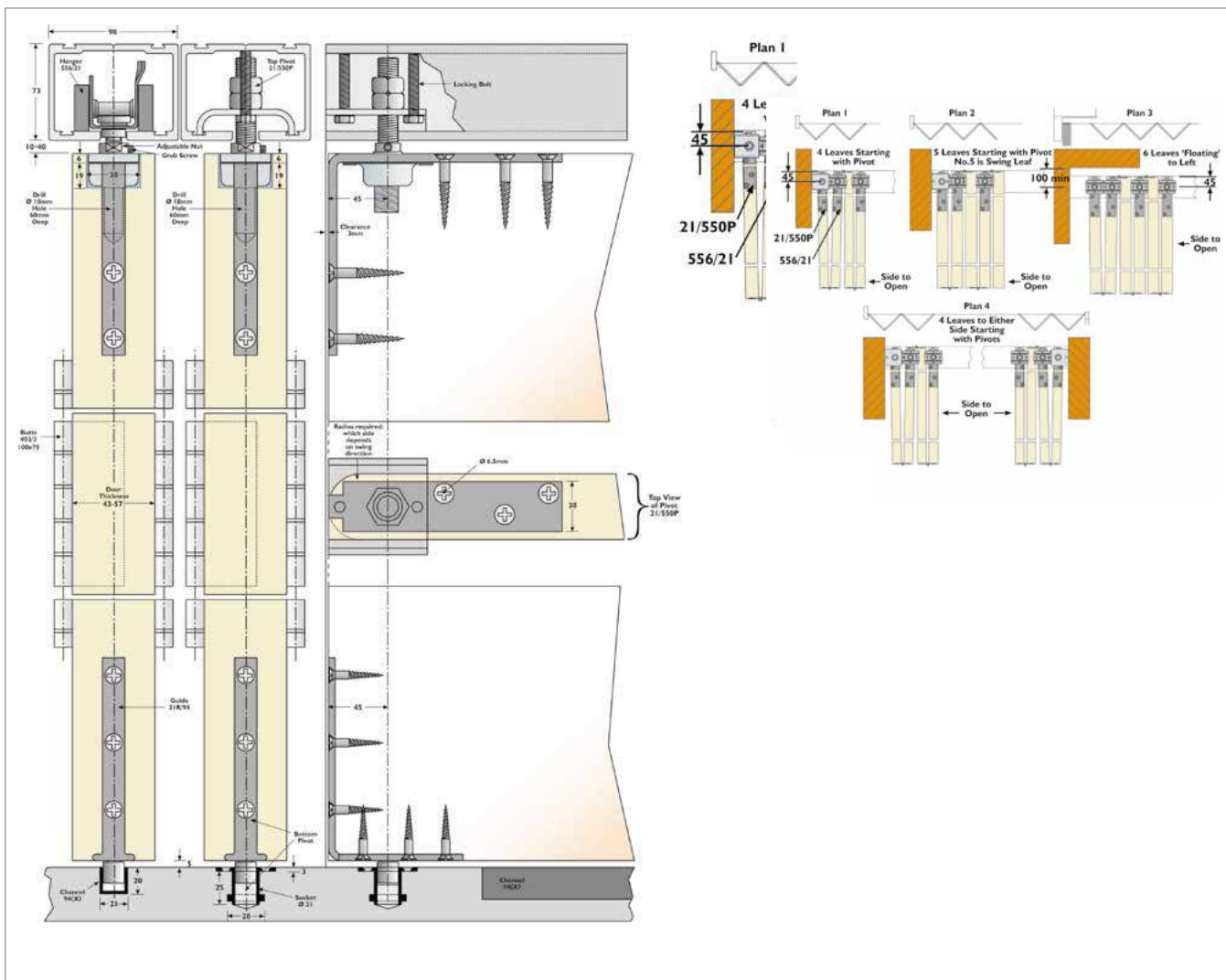

Hardware

Track



550



550M

Brackets



1A/550



3S/550

Hangers



556/21

Pivots



21/550P

Guides



21R/94

Hinge



403/3

Guide Channel



94



94X

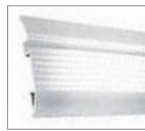

94T

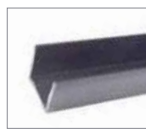

94P



94SC

Accessories



Flush Bolt (454) Satin anodised aluminium



Flush Bolt (FB110S) Non locking

View our full range of accessories on page 136

FLEXIROL CENTREFOLD

For heavyweight centre folding wooden partition doors weighing up to 125kg



Specifically developed for commercial applications requiring heavyweight, top hung, central folding wooden partition doors. Doors are hung centrally and can fold to one or both sides. For applications hinged to the jam 3.5, 5.5 or 7.5 doors can be used with the half door hinged to the jam. For best operation of floating units, 5, 7 or 9 doors should be used. Any access doors should be hinged separately to the jamb.

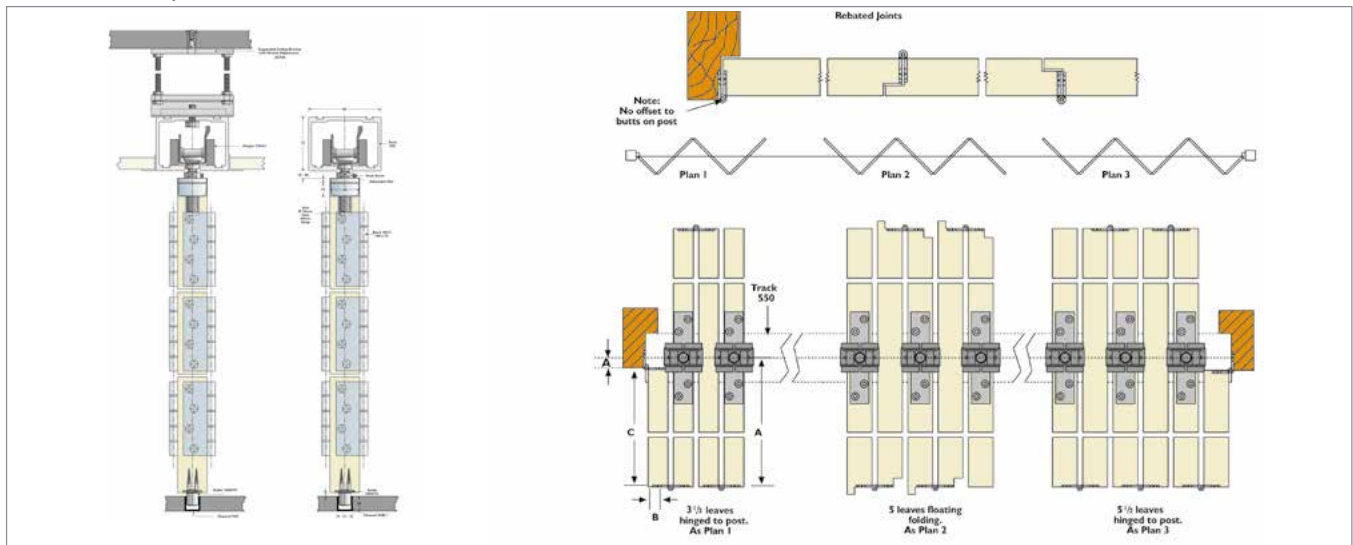

Product Information



Product	Max. Door Height	Max. Door Width	Door Thickness Range	Max. Door Weight
Flexirol Centrefold	4500mm	1200mm	43 - 57mm	125kg

Product Specification

Component	Description	Short Code
Track Equal to opening width	White aluminium track in 2000, 2500, 3000, 4000, 5000 and 6000mm lengths	550/****
	Aluminium mill finish track in 2000, 3000, 4000, 5000 and 6000mm lengths	550/****M
Brackets At 500mm intervals	Face fixed bracket	1A/550
	Soffit fixed bracket, adjustable	3S/550
Hangers	Top fixing plate hanger	556/61
Guides	Nylon roller guide	106N/94
Hinge	Butt hinge	403/3
Guide Channel	Brass guide channel in 1500 and 3000mm lengths	94/****
	Aluminium guide channel in 1500, 2000, 2500, 3000, 4000 and 6000mm lengths	94X/****
	Aluminium threshold in 2000, 2500, 3000, 3500, 4000 and 6000mm lengths	94T/****

**** Replace by length of track for full short code

Hardware

Track	Brackets	Hanger	Guide	Hinge	Guide Channel
					
550	550M	1A/550	3S/550	556/61	106N/94
					403/3
					94
					94X
					94T

Accessories [View our full range of accessories on page 136](#)

SECUREFOLD

The ultimate folding door hardware system for doors weighing up to 50kg, 100kg and 150kg



Twinbolt



Securefold 100

Securefold offers the very best in exterior folding door hardware systems to help you securely open up an interior space to the outside world. The system has been designed for residential and commercial applications for top hung, exterior wooden or aluminium doors weighing up to 50kg, 100kg and 150kg. With all components made from marine grade 316 stainless steel, the system is extremely resistant against the elements and corrosion. The system comes in a range of stunning finishes including satin, chrome, gold and black meaning it can complement existing hardware and virtually any colour scheme.

The system operates with effortless ease and combines all the aesthetic benefits of folding wooden doors with the additional advantages of uncompromising security and durability.



Available in four stunning finishes

Securefold 100 features all the benefits of both the 50 and 150 with the addition of a further enhancement, R-Loc - a clever ratchet system that enables installers to easily raise and lower a door.

Securefold Specifier

Use our online Securefold Specifier tool to quickly build a bill of materials or get a quotation www.pchenderson.com/securefold-specifier

Product Information

Product	Max. Door Height	Max. Door Width	Door Thickness Range*	Max. Door Weight
Securefold 50	3300mm	1000mm	35 - 68mm	50kg
Securefold 100	3300mm	1000mm	35 - 68mm	100kg
Securefold 150	4000mm	1200mm	45 - 68mm	150kg
Securefold Ultra	3300mm	1000mm	48 - 68mm	100kg

*For thick and/or narrow width doors please consult the fitting instructions regarding 'camming'. For doors between 35 - 47mm use an alternative flushbolt. Contact our technical team for further information.

SECUREFOLD 50

Product Specification

Component	Description	Mortice Standard	Mortice Square	Non Mortice
Track	Anodised aluminium track - 2000, 2500, 3000, 3500, 4000, 5000 and 6000mm	180/****		
Pivot	Pivot assembly	SF1*50	SFM1*50	SFW1*50
Hanger*	End hanger, left hand (handed inside looking out)	SF2L*50	SFM2L*50	SFW2L*50
	End hanger, right hand (handed inside looking out)	SF2R*50	SFM2R*50	SFW2R*50
	Intermediate hanger set	SF4*50	SFM4*50	SFW4*50
	End hanger rebated meeting kit (for 2 x rebated meeting doors)	SF8*50	SFM8*50	SFW8*50
Hinges	Hinge handle set outward opening	SF3*	SFM3*	SF3*
	Hinge set inward opening	SF5*	SFM5*	SF5*
	Hinge set offset inward opening	SF6*	SFM6*	SF6*
	Hinge handle offset outward opening	SF7*	SFM7*	SF7*
	Intermediate pivot hinge	SF9*	SFM9*	SFW9*50
Threshold	Aluminium threshold in satin - 2000, 2500, 3000, 3500, 4000, 5000 and 6000mm	SF94T/****		
	Aluminium threshold in bronze - 2000, 2500, 3000, 3500, 4000 and 6000mm	SF94T/****BZ		
	Threshold jamb kit	SF94T/JAMB		
Channel	Polypropylene channel in black -2000, 2500, 3000, 3500, 4000, 5000 & 6000mm	94P/****		
	Anod. alum. support channel - 2000, 2500, 3000, 3500, 4000, 5000 & 6000mm	94SC/****		
Seals	Door perimeter seal in brown or white	AQ63B or AQ63W		
	Frame perimeter seal in brown or white	AQ21B or AQ21W		
	Track seal in black, 10mm length (per metre)	BS10B		
Flush Bolts (Non Locking)	For outward opening doors in 190, 450 or 600mm lengths (top or bottom of door)	SF190* or SF450* or SF600*		
	For inward opening doors in 190, 450 or 600mm lengths (top of door)	SF190IT* or SF450IT* or SF600IT*		
	For inward opening doors in 190mm length (bottom of door)	SF190IB*		
Flush Bolts (Locking)	For outward opening doors in 190, 450 or 600mm lengths (top or bottom of door) (600mm only available in satin and black)	SF190L* or SF450L* or SF600L*		
	For inward opening doors in 190mm length (bottom of door)	SF190IBL*		
Handle	Handle for Securefold	SF10*		

**** Replace by length of track for full short code

*Replace with required colour for full short code - satin, chrome or black

SECUREFOLD 100

Product Specification

Component	Description	Mortice Standard	Mortice Square	Non Mortice
Track	Anodised aluminium track - 2000, 2500, 3000, 3500, 4000, 5000 and 6000mm	250/****		
Pivot	Pivot assembly	SF1*	SFM1*	SFW1*
Hanger*	End hanger, left hand (handed inside looking out)	SF2L*	SFM2L*	SFW2L*
	End hanger, right hand (handed inside looking out)	SF2R*	SFM2R*	SFW2R*
	Intermediate hanger set	SF4*	SFM4*	SFW4*
	End hanger rebated meeting kit (for 2 x rebated meeting doors)	SF8*	SFM8*	SFW8*
Hinges	Hinge handle set outward opening	SF3*	SFM3*	SF3*
	Hinge set inward opening	SF5*	SFM5*	SF5*
	Hinge set offset inward opening	SF6*	SFM6*	SF6*
	Hinge handle offset outward opening	SF7*	SFM7*	SF7*
	Intermediate pivot hinge (SFM9* available in satin, gold and black only)	SF9*	SFM9*	SFW9*
Threshold	Aluminium threshold in satin - 2000, 2500, 3000, 3500, 4000, 5000 and 6000mm	SF94T/****		
	Aluminium threshold in bronze - 2000, 2500, 3000, 3500, 4000 and 6000mm	SF94T/****BZ		
	Threshold jamb kit	SF94T/JAMB		
Channel	Polypropylene channel in black -2000, 2500, 3000, 3500, 4000, 5000 & 6000mm	94P/****		
	Anod. alum. support channel - 2000, 2500, 3000, 3500, 4000, 5000 & 6000mm	94SC/****		
Seals	Door perimeter seal in brown or white	AQ63B or AQ63W		
	Frame perimeter seal in brown or white	AQ21B or AQ21W		
	Track seal in black, 10mm length (per metre)	BS10B		
Flush Bolts (Non Locking)	For outward opening doors in 190, 450 or 600mm lengths (top or bottom of door)	SF190* or SF450* or SF600*		
	For inward opening doors in 190, 450 or 600mm lengths (top of door)	SF190IT* or SF450IT* or SF600IT*		
	For inward opening doors in 190mm length (bottom of door)	SF190IB*		
Flush Bolts (Locking)	For outward opening doors in 190, 450 or 600mm lengths (top or bottom of door) (only available in satin or black)	SF190L* or SF450L* or SF600L*		
	For inward opening doors in 190 mm length (bottom of door)	SF190IBL*		
Handle	Handle for Securefold	SF10*		

**** Replace by length of track for full short code

*Replace with required colour for full short code - satin, chrome, gold or black

SECUREFOLD 150

Product Specification

Component	Description	Mortise Standard
Track	Anodised aluminium track - 2000, 3000, 4000, 5000 and 6000mm	480/****
Pivot	Pivot assembly	SF1S150
Hanger*	End hanger set	SF2S150
	Intermediate hanger set	SF4S150
	End hanger rebated meeting kit (for 2 x rebated meeting doors)	SF8S150
Hinges	Hinge handle set outward opening	SF3S150
	Hinge handle offset outward opening	SF7S150
	Intermediate pivot hinge	SF9S150
Channel	Polypropylene channel in black -2000, 3000, 4000, 5000 & 6000mm	98P/****
	Anod. alum. support channel - 2000, 3000, 4000, 5000 & 6000mm	98SC/****
Seals	Door perimeter seal in brown	AQ33B
	Frame perimeter seal in brown or white	AQ21B or AQ21W
	Track seal in black, 15mm length (per metre)	BS15B
Flush Bolts (Non Locking)	For outward opening doors in 190, 450 or 600mm lengths (top or bottom of door)	SF190S or SF450S or SF600S
Flush Bolt (Locking)	For outward opening doors in 190, 450 or 600mm lengths (top or bottom of door)	SF190LS or SF450LS or SF600LS
Handle	Handle for Securefold	SF10S150

**** Replace by length of track for full short code

SECUREFOLD ULTRA

Product Specification

Component	Description	Mortise Standard
Track	Anodised aluminium track - 2000, 2500, 3000, 3500, 4000, 5000 and 6000mm	250/****
Pivot	Pivot assembly	SFU1*
Hanger*	End hanger, left hand (handed inside looking out)	SFU2L*
	End hanger, right hand (handed inside looking out)	SFU2R*
	Intermediate hanger set	SFU4*
	End hanger rebated meeting kit (for 2 x rebated meeting doors)	SF8*
Hinges	Hinge handle set outward opening	SF3*
	Hinge handle offset outward opening	SF7*
	Intermediate pivot hinge	SFU9*
Channel	Polypropylene channel in black -2000, 2500, 3000, 3500, 4000, 5000 & 6000mm	94P/****
	Anod. alum. support channel - 2000, 2500, 3000, 3500, 4000, 5000 & 6000mm	94SC/****
Seals	Door perimeter seal in brown or white	AQ63B or AQ63W
	Frame perimeter seal in brown or white	AQ21B or AQ21W
	Track seal in black, 15mm length (per metre)	BS15B
Flush Bolts (Locking)	For outward opening doors in 190, 450 or 600mm lengths (top or bottom of door) (only available in satin or black)	SF190L* or SF450L* or SF600L*
Handle	Handle for Securefold	SF10*

**** Replace by length of track for full short code

*Replace with required colour for full short code - satin, chrome, gold or black

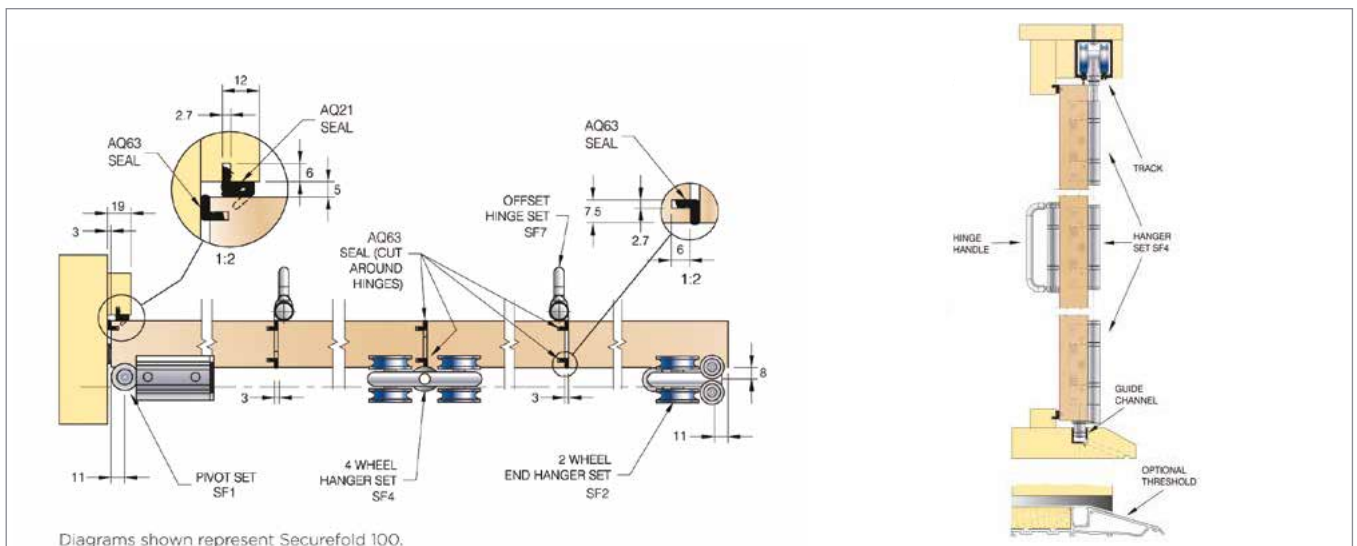

TWINBOLT

Alternative locking system for Securefold 50, 100 and 150

Component	Description	Securefold 50 and 100			Securefold 150
		Mortice Standard	Mortice Square	Non Mortice	
Twinbolt	Twin locking system for Securefold	TB/SF	TB/SFM	TB/SF	TB/SF150
Twinbolt Handle	Handle for Twinbolt system	TWINHAN/S			
Routing Cover Strip	Available in brown, black or white	TBCS/BR or TBCS/BL or TBCS/WH			



HINGE OPTIONS

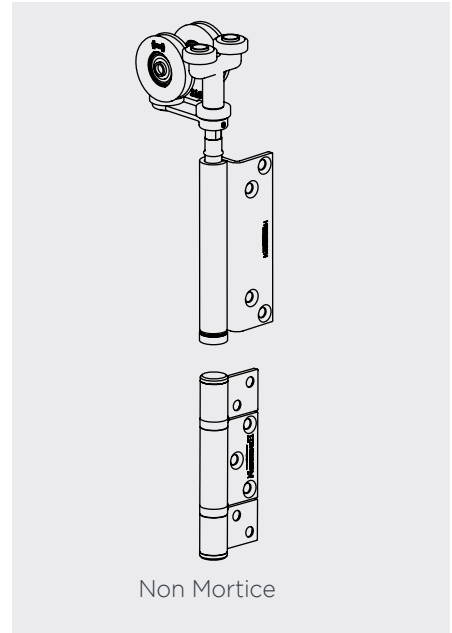
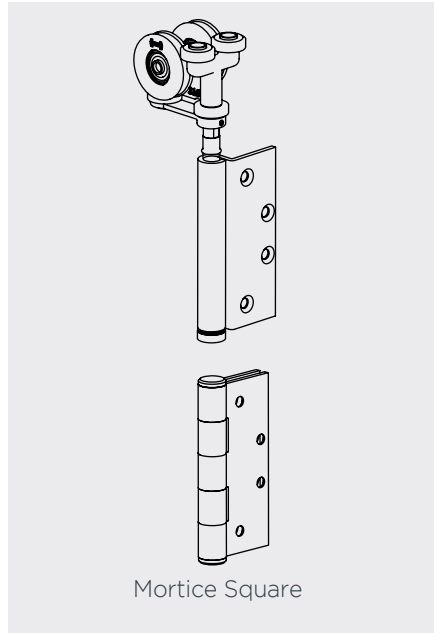
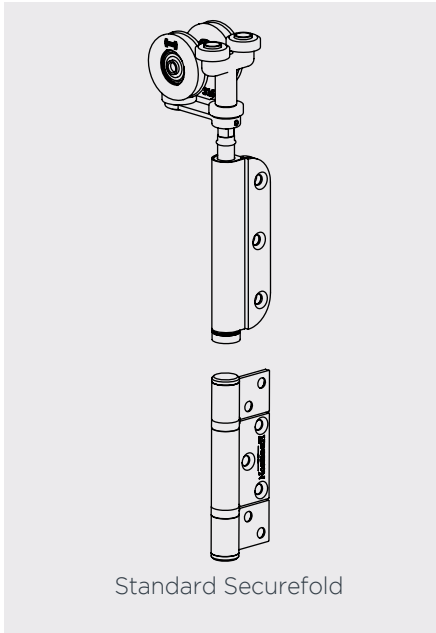

P C Henderson offer a choice of three different hinge options in the Securefold range, this enables us to offer our customers a choice in the look and feel of their project as well as variances on the preferred method of installation and door material. Please note for Securefold 150 and Securefold Ultra, mortice standard hinges must be used.

Mortice Standard

The Securefold standard hinge option combines mortice end door pivots to create a clean finish. The pivot is concealed between the door and the jamb and uses the trusted surface mounted intermediate hinges for ease of installation across the remaining door configurations. The standard hinge is suitable for all wooden doors which are 35-68mm thick and weighing up to 150kg. This is a popular option when specifying internal or external folding.

Mortice Square

Square edged hinges provide a rustic feel and look to any wood work application and these are often chosen for more traditional applications. The solid square appearance achieves the look of a timely installation as historically this would have required precision routing by hand. Today there are other methods but some customers still prefer the hand carved qualities of traditional joinery. This hinge option is suitable for use on wooden doors between 44 - 68mm thick and weighing up to 100kg.

Non Mortice

A non mortice hinge is an entirely surface mounted system that requires no routing or additional preparation before the fitting process. This is an easy and versatile option of hardware which can be used on wooden or aluminium doors between 35-68mm thick and weighing up to 100kg.

Accessories



Magnet Set (MAG/*) for between doors



Magnet Set (SWMAG/*) for swing door









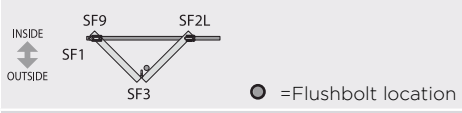
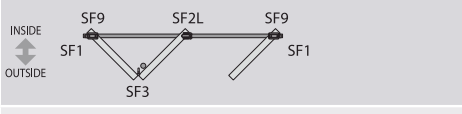
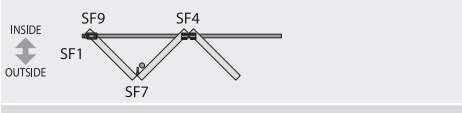
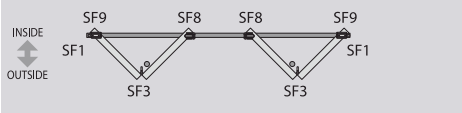

Router Tool (ROUTER) for routing detail of flush bolts

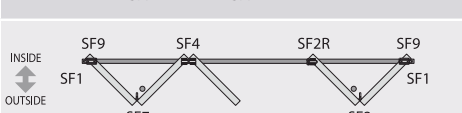
View our full range of accessories on page 136

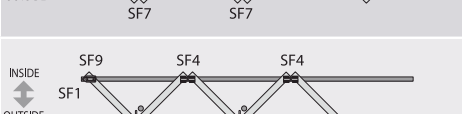
* Replace with first letter of required colour for full short code (satin, chrome, gold or black)

Outward Door Configurations and Hardware Quantities

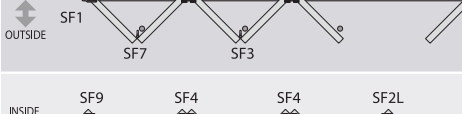
Door Configuration	Hardware	Securefold Ultra Hardware Kits †
2 Leaf 	2 x SF flushbolt, 1 x SF1 pivot set, 1 x SF3 hinge set with handle, 1 x SF2L end hanger set - left hand.*	1 x SFU1, 1 x SFU9, 1 x SFU2
2 + 1 Leaf 	2 x SF flushbolt, 2 x SF1 pivot set, 1 x SF3 hinge set with handle, 1 x SF2L end hanger set - left hand.*	2 x SFU1, 2 x SFU2, 2 x SFU9
3 Leaf 	2 x SF flushbolt, 1 x SF1 pivot set, 1 x SF4 intermediate hanger set, 1 x SF7 offset hinge set with handle.	1 x SFU1, 1 x SFU9, 1 x SFU4
2 + 2 Leaf 	4 x SF flushbolt, 2 x SF1 pivot set, 2 x SF3 hinge set with handle, 1 x SF8 rebated end hanger meeting.	2 x SFU1, 2 x SFU9
3 + 1 Leaf 	4 x SF flushbolt, 2 x SF1 pivot set, 1 x SF4 intermediate hanger set, 1 x SF7 offset hinge set with handle.	2 x SFU1, 2 x SFU9, 1 x SFU4
4 Leaf 	4 x SF flushbolt, 1 x SF1 pivot set, 1 x SF4 intermediate hanger set, 2 x SF7 offset hinge set with handle, 1 x SF2L end hanger set - left hand.*	1 x SFU1, 1 x SFU9, 1 x SFU4, 1 x SFU2
3 + 2 Leaf 	4 x SF flushbolt, 2 x SF1 pivot set, 1 x SF3 hinge set with handle, 1 x SF4 intermediate hanger set, 1 x SF7 offset hinge set with handle, 1 x SF2R end hanger set - right hand.*	2 x SFU1, 2 x SFU9, 1 x SFU4, 1 x SFU2
4 + 1 Leaf 	4 x SF flushbolt, 2 x SF1 pivot set, 1 x SF4 intermediate hanger set, 2 x SF7 offset hinge set with handle, 1 x SF2L end hanger set - left hand.*	2 x SFU1, 2 x SFU9, 1 x SFU4, 1 x SFU2
5 Leaf 	4 x SF flushbolt, 1 x SF1 pivot set, 1 x SF3 hinge set with handle, 2 x SF4 intermediate hanger set, 1 x SF7 offset hinge set with handle.	1 x SFU1, 1 x SFU9, 2 x SFU4
3 + 3 Leaf 	6 x SF flushbolt, 2 x SF1 pivot set, 2 x SF4 intermediate hanger set, 2 x SF7 offset hinge set with handle.	2 x SFU1, 2 x SFU9, 2 x SFU4
4 + 2 Leaf 	6 x SF flushbolt, 2 x SF1 pivot set, 1 x SF3 hinge set with handle, 1 x SF4 intermediate hanger set, 2 x SF7 offset hinge set with handle, 1 x SF8 rebated end hanger meeting.	2 x SFU1, 2 x SFU9, 1 x SFU4
5 + 1 Leaf 	6 x SF flushbolt, 2 x SF1 pivot set, 1 x SF3 hinge set with handle, 2 x SF4 intermediate hanger set, 1 x SF7 offset hinge set with handle.	2 x SFU1, 2 x SFU9, 2 x SFU4
6 Leaf 	6 x SF flushbolt, 1 x SF1 pivot set, 1 x SF3 hinge set with handle, 2 x SF4 intermediate hanger set, 2 x SF7 offset hinge set with handle, 1 x SF2L end hanger set - left hand.*	1 x SFU1, 1 x SFU9, 2 x SFU4, 1 x SFU2

Product Information

SF1 pivot assembly set	SF7 hinge set offset outward opening
SF2R end hanger set (RH)	SF8 rebated end hanger meeting
SF2L end hanger set (LH)	SF9 intermediate pivot hinge (optional)
SF4 intermediate hanger set	SF10 face fix handle (optional)
SF5 hinge set inward opening	SF flushbolt
SF3 hinge set with handle	

To add surface mounted hinges replace:

SF1 with SFW1
 SF2 with SFW2
 SF8 with SFW8
 SF9 with SFW9
 (only available for standard Securefold)

†All Securefold Ultra hardware kits come complete with certified hardware, multipoint lock-available in brushed satin, polished stainless steel, gold and black finishes. Specify only track and seals required to complete the specification.

The configurations shown above are viewed from the outside. They can be reversed, if reversed the parts marked * will have to be the opposite handing e.g. "SFW2R/SF2R end hanger set - right hand" will become "SFW2L/SF2L end hanger set - left hand" and "SFW2L/SF2L end hanger set - left hand" will become "SFW2R/SF2R end hanger set - right hand". SFW9 intermediate pivot is optional for doors exceeding 2200mm in height. The SFW8 (rebated end hanger meeting) is illustrated in the split position on each door. Only one kit is required per door meeting point. ** Ultra only available outward opening. On systems using door leaves that are narrow and wide and the hypotenuse is more than the door width x 1.004 then a risk of camming exists (see fitting instructions for further information). Please contact our Technical Customer Services Team for further information.

HARDWARE APPLICATION

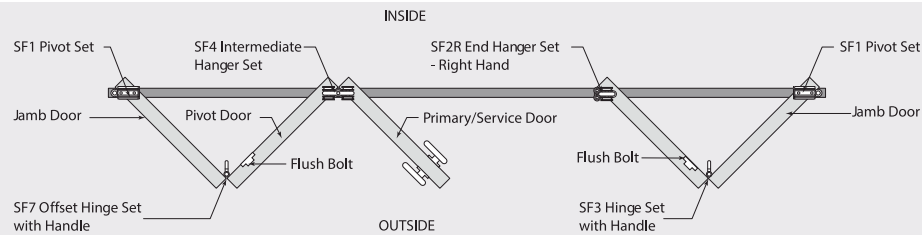

Inward Door Configurations and Hardware Quantities

Door Configuration		Securefold hardware
2 Leaf		2 x SF flushbolt, 1 x SF1 pivot set, 1 x SF5 hinge set inward opening, 1 x SF2R end hanger set - right hand.*
2 + 1 Leaf		2 x SF flushbolt, 2 x SF1 pivot set, 1 x SF5 hinge set inward opening, 1 x SF2R end hanger set - right hand.*
3 Leaf		2 x SF flushbolt, 1 x SF1 pivot set, 1 x SF6 offset hinge set inward opening, 1 x SF4 intermediate hanger set.
2 + 2 Leaf		4 x SF flushbolt, 2 x SF1 pivot set, 2 x SF5 hinge set inward opening, 1 x SF8 rebated end hanger meeting.
3 + 1 Leaf		4 x SF flushbolt, 2 x SF1 pivot set, 1 x SF6 offset hinge set inward opening, 1 x SF4 intermediate hanger set.
4 Leaf		4 x SF flushbolt, 1 x SF1 pivot set, 2 x SF6 offset hinge set inward opening, 1 x SF4 intermediate hanger set, 1 x SF2R end hanger set - right hand.*
3 + 2 Leaf		4 x SF flushbolt, 2 x SF1 pivot set, 1 x SF4 intermediate hanger set, 1 x SF5 hinge set inward opening, 1 x SF6 offset hinge set inward opening, 1 x SF2L end hanger set - left hand.*
4 + 1 Leaf		4 x SF flushbolt, 2 x SF1 pivot set, 1 x SF4 intermediate hanger set, 2 x SF6 offset hinge set inward opening, 1 x SF2R end hanger set - right hand.*
5 Leaf		4 x SF flushbolt, 1 x SF1 pivot set, 2 x SF4 intermediate hanger set, 1 x SF5 hinge set inward opening, 1 x SF6 offset hinge set inward opening.
3 + 3 Leaf		6 x SF flushbolt, 2 x SF1 pivot set, 2 x SF4 intermediate hanger set, 2 x SF6 offset hinge set inward opening.
4 + 2 Leaf		6 x SF flushbolt, 2 x SF1 pivot set, 1 x SF4 intermediate hanger set, 1 x SF5 hinge set inward opening, 2 x SF6 offset hinge set inward opening, 1 x SF8 rebated end hanger meeting.
5 + 1 Leaf		6 x SF flushbolt, 2 x SF1 pivot set, 2 x SF4 intermediate hanger set, 1 x SF5 hinge set inward opening, 1 x SF6 offset hinge set inward opening.
6 Leaf		6 x SF flushbolt, 1 x SF1 pivot set, 2 x SF4 intermediate hanger set, 1 x SF5 hinge set inward opening, 2 x SF6 offset hinge set inward opening, 1 x SF2R end hanger set - right hand.*

The configurations shown above are viewed from the inside. They can be reversed, if reversed the parts marked * will have to be the opposite handing e.g. "SF2R end hanger set - right hand" will become "SF2L end hanger set - left hand" and "SF2L end hanger set - left hand" will become "SF2R end hanger set - right hand". The SF8 (rebated end hanger meeting) is illustrated in the split position on each door. Only one kit is required per door meeting point.

Multidirectional



Our range of multidirectional door hardware systems offer unparalleled flexibility without compromising on the practicality of the application. The system offers a choice of two hangers providing either 90° or 135° movement for wooden, metal and glass panels weighing up to 100kg and 500kg.

The range is ideal for shop fronts, internal partitions, moveable walls, conference rooms, restaurants or any application that requires the flexibility of a stacking system which can be stored to the side, clear of the opening.

Range Overview

- Catering for maximum door weights of up to 100kg and 500kg
- Available in 90° or 135° movement
- Suitable for wood, metal or glass panels
- Interior and exterior applications
- Panels stack to the side leaving a clear opening
- Ability to create bespoke stacking areas away from the entrance

FLEXIROL MULTIDIRECTIONAL

For light weight and heavy weight doors requiring 90° or 135° movement



Our Flexirol Multidirectional comes in two product variations - Flexirol Multidirectional 90 and Flexirol Multidirectional 135. The 90 degree system is designed for panels up to 100kg for both residential and commercial environments. The 135 degree system is designed for panels up to 500kg, for use in residential and commercial environments. The system can also be made entirely bespoke and tailored to your exact requirements.

Catering for wooden and aluminium doors, the system is ideal for shop fronts, internal room partitions, conference centres and showrooms. The stacking formation allows panels to be stored entirely clear of the opening.

For exterior applications please consult the P C Henderson technical team.

Product Information

Product	Max. Door Height	Max. Door Width	Door Thickness Range	Max. Swing Door Width	Max. Door Weight (2 Hangers per Door)
Flexirol Multidirectional 90	6000mm	6000mm	40 - 100mm	1200mm	100kg
Flexirol Multidirectional 135	6000mm	6000mm	40 - 100mm	1200mm	500kg

Product Specification

Component	Description	Flexirol MD 90 Short Code	Flexirol MD 135 Short Code
Track	White aluminium track - 2000, 2500, 3000, 4000, 5000 & 6000mm lengths	550/****	550/****
	Mill finish track - 2000, 3000, 4000, 5000 and 6000mm lengths	550/****M	550/****M
Intersects	T junction - white	TW/550	-
	T junction - mill	TW/550M	-
	Cross junction - white	KW/550	-
	135° right-hand - mill	-	W45R/550M
	135° left-hand - mill	-	W45L/550M
Elbows	90° elbow - white	H90/550	-
	90° elbow - mill	H90/550M	-
	135° swept elbow - white	-	H135/550
	135° swept elbow - mill	-	H135/550M
	90° swept elbow for 135° hanger - white	-	H90C/550
	90° swept elbow for 135° hanger - mill	-	H90C/550M
Hangers 2 per door	Angle plate fixing	555/21	556/21
	Concealed fixing	555/61	556/61
	Metal hanger	555	556
Pivots	Pivot set	21/550P	21/550P
Brackets	Face fixed	1A/550	1A/550
	Suspended soffit fixed	3S/550	3S/550
Stops	Track stop	HH3/301	HH3/301

**** Replace by length of track for full short code.

FLEXIROL MULTIDIRECTIONAL 90

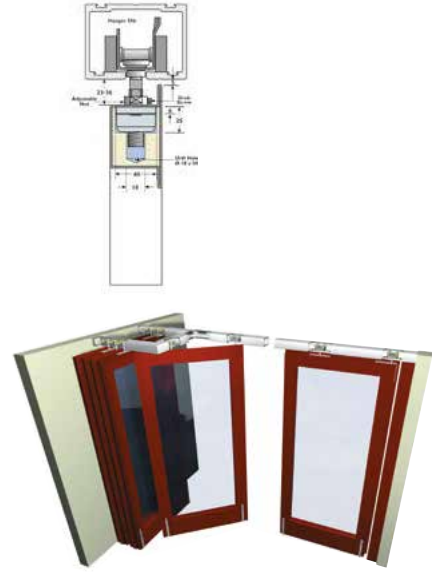
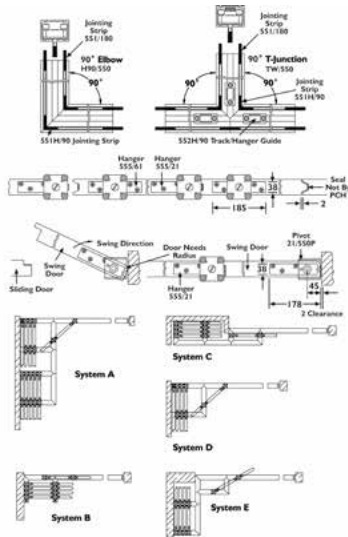
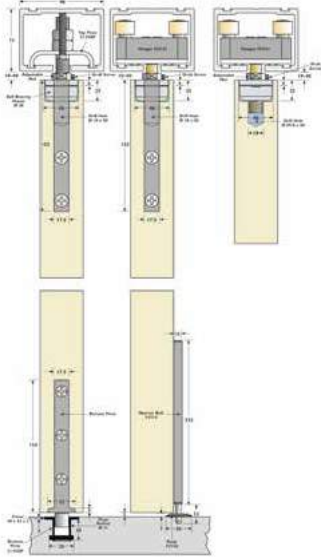

FLEXIROL MULTIDIRECTIONAL 135

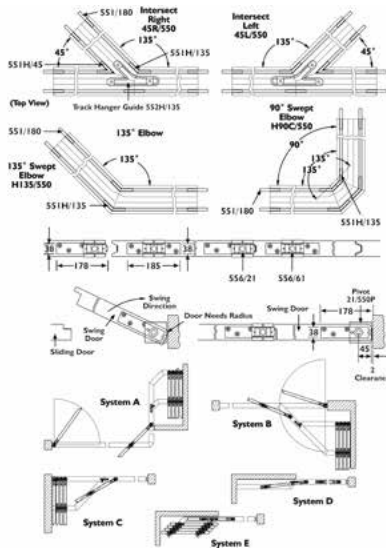
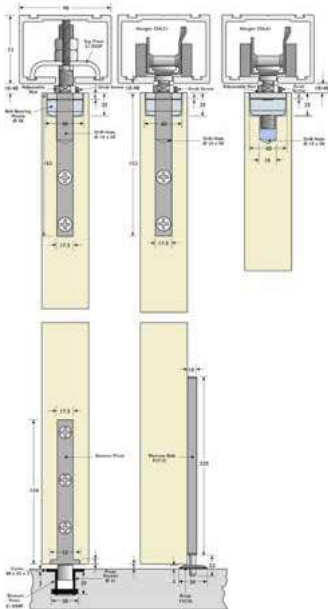

Hardware

Track



550M

Intersects



TW/550M

Elbows



W45R/550



W45L/550

Elbows



H90/550M



H135/550M



H90C/550M

Hangers



555/21

Hangers



556/21



555/61



556/61



555



556

Pivots



21/550P

Brackets



1A/550



3S/550

Stop



HH3/301

Accessories



Track Jointing Strip (551H/180)

[View our full range of accessories on page 136](#)

FLEXIROL MULTIDIRECTIONAL GLASS

For glass doors weighing up to 500kg requiring 90° or 135° movement



Flexirol Multidirectional Glass is designed for glass panels, in residential or commercial environments, requiring 90° or 135° flexible movement options. The system is ideal for shop fronts of internal room partitions and also benefits from a stacking formation, which allows the doors to be stored clear of the threshold.

Product Information

Product	Max. Door Height	Max. Door Width	Max. Swing Door Width	Glass Thickness	Max. Door Weight
Flexirol Multidirectional Glass 90	4000mm	1000mm per 100kg of glass	1200mm	10mm or 12mm	100kg
Flexirol Multidirectional Glass 135	4000mm	1000mm per 100kg of glass	1200mm	10mm or 12mm	500kg

Product Specification

Component	Description	Flexirol MD Glass 90 Short Code	Flexirol MD Glass 135 Short Code
Track	White aluminium track in 2000, 2500, 3000, 4000, 5000 & 6000mm	550/****	550/****
	Aluminium mill finish track in 2000, 3000, 4000, 5000 and 6000mm	550/****M	550/****M
Brackets	Face fixed bracket	1A/550	1A/550
	Soffit fixed bracket - suspended ceiling	3S/550	3S/550
Hangers	90° or 135° hanger	555	556S
Glass Profile	Top and bottom glass profile (made to measure)	FRP02	FRP02
Pivots	Pivot set	21/550GP	21/550GP
Stop	Track stop	HH3/301	HH3/301

**** Replace by length of track for full short code.

FLEXIROL MULTIDIRECTIONAL 90

Multidirectional door

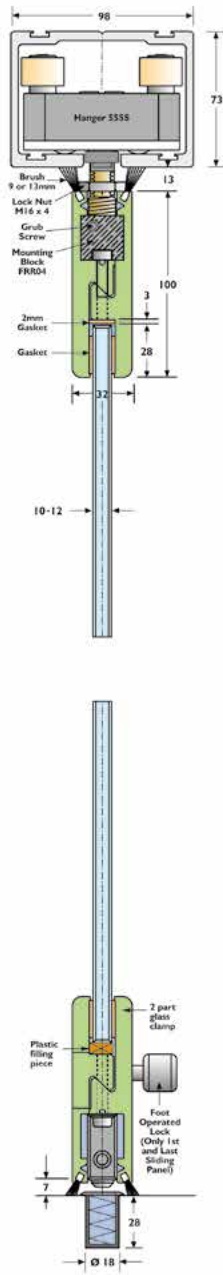

Swing door

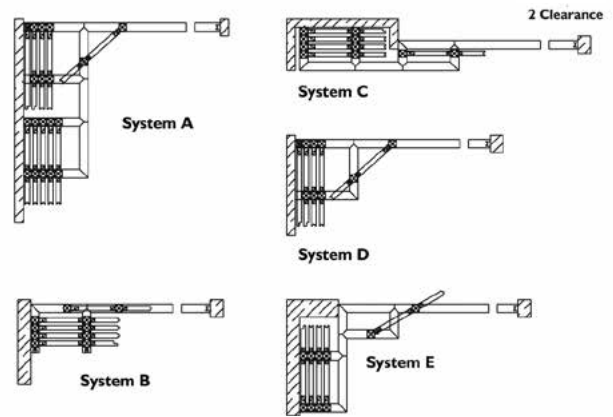
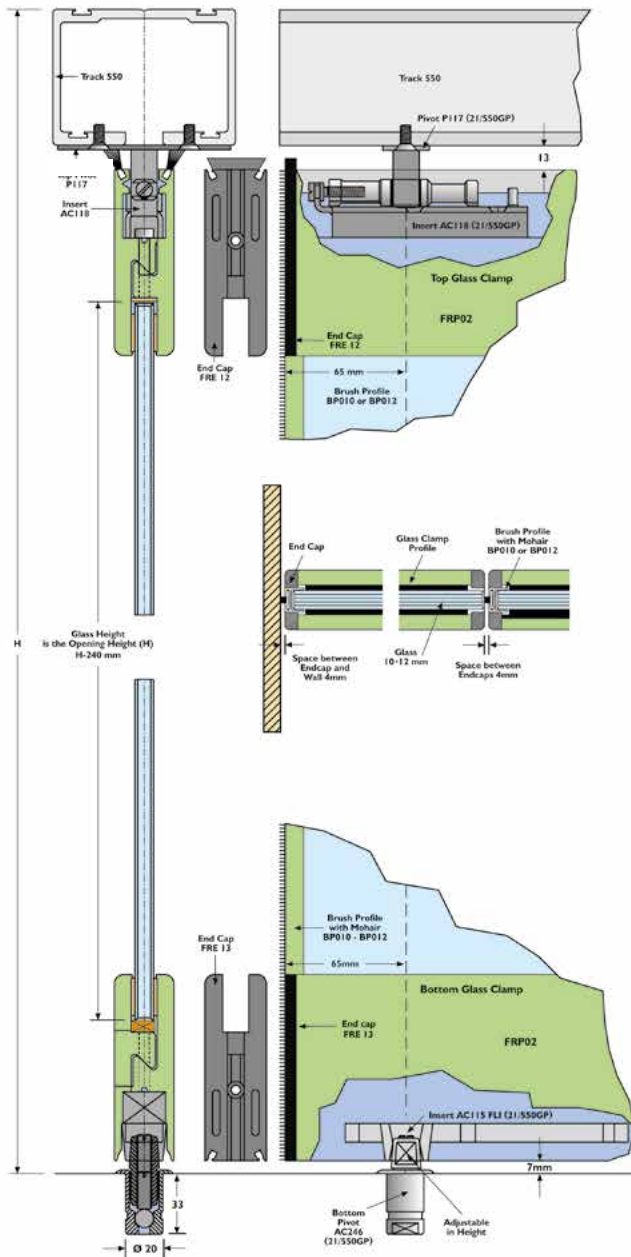

FLEXIROL MULTIDIRECTIONAL 135

Multidirectional door

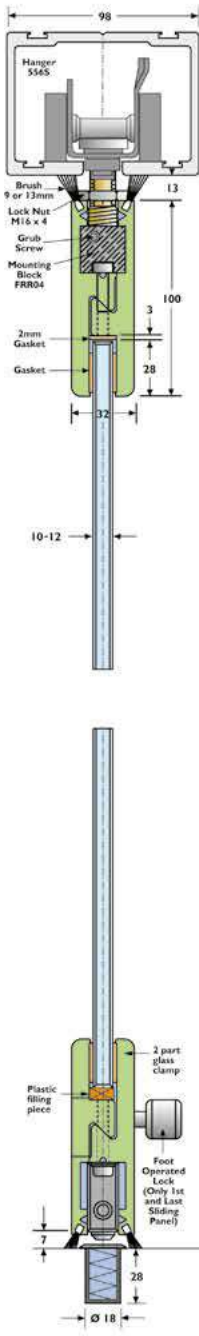

Swing door

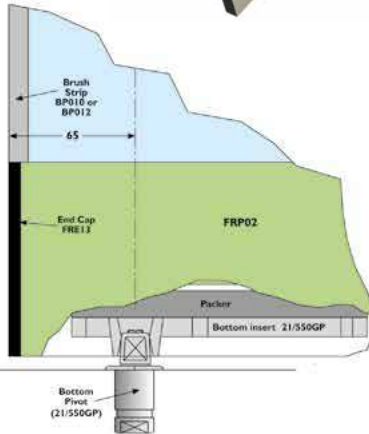
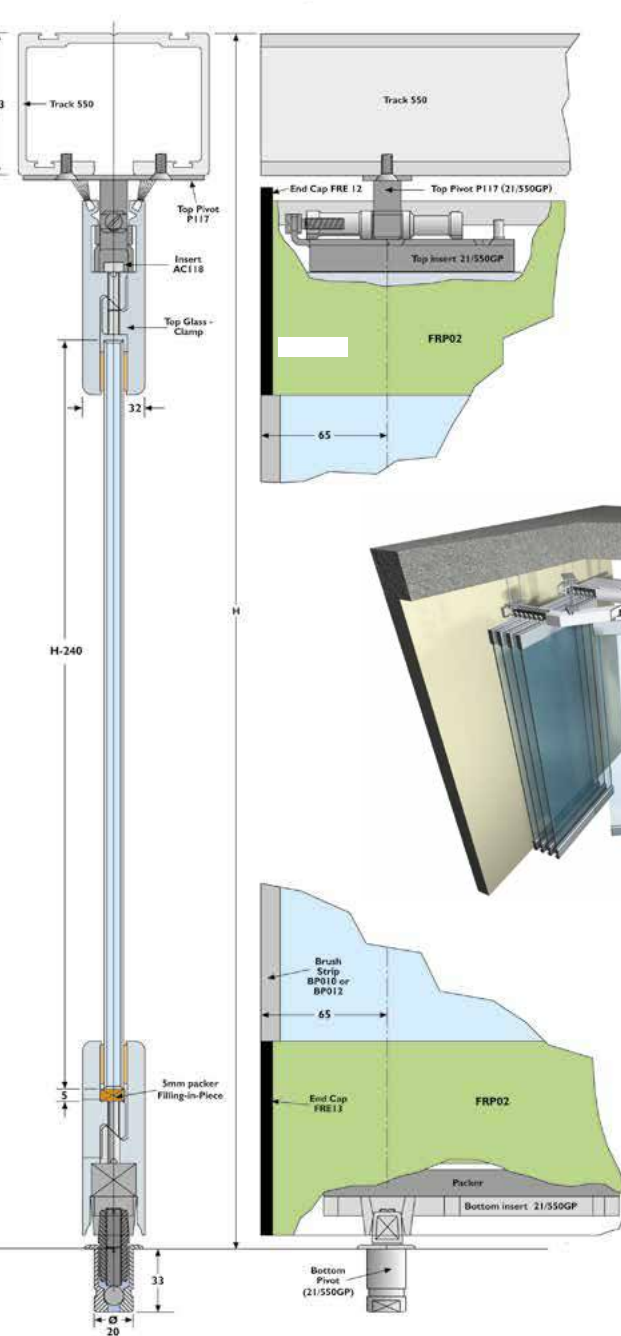

Hardware

Track



550

Brackets



1A/550



3S/550

Hangers



555



556S

Glass Profile



FRP02

Pivot



21/550GP

Stop



HH3/301

Accessories

[View our full range of accessories on page 136](#)

Round the Corner



A robust range of top hung systems for round the corner applications where a unit of stacked doors would be impractical or unsuitable. Our round-the-corner range is suitable for maximum door weights of between 35kg and 70kg and can cater for wooden or metal doors.

Ideally suited for residential garages, commercial and light industrial applications, the system works whereby the doors slide around the corner, clear of the opening, and park along the adjacent side walls. The doors can slide to one or both sides of the opening, offering further flexibility.

Range Overview

- Catering for maximum door weights of up to 35kg and 70kg
- Suitable for wooden or metal doors
- Exterior applications
- Doors rest on adjacent wall
- Ideal solution for where a unit of stacked doors is unsuitable

TANGENT ROUND THE CORNER

Top-hung door system for round the corner applications



Tangent Round the Corner is a robust top hung door system for round the corner residential, commercial or light industrial wooden or metal doors. The doors may be panelled, flushed or glazed and can weigh up to 35kg, 55kg or 70kg each. The system is particularly suited where a bunched unit of parked panels would be impractical.

Only 3 to 5 panels should be hinged in 1 unit, but any number of units may be used to suit panels from a minimum width of 711mm to a maximum of 900mm.

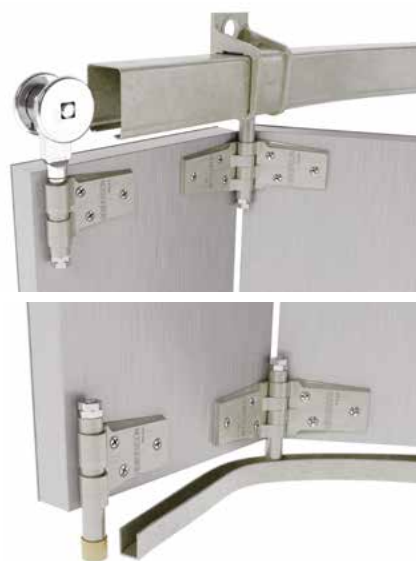

Product Information

Product	Min. Door Width	Max. Door Width	Door Thickness Range	Max. Door Weight
Tangent RTC 290	711mm	900mm	35 - 50mm	35kg
Tangent RTC 301	711mm	900mm	45 - 55mm	55kg
Tangent RTC 301H	711mm	900mm	45 - 55mm	70kg

Product Specification

Component	Description	290 Short Code	301 Short Code	301H Short Code
Track	Available in 2000, 2500, 3000, 4000, 5000 & 6000mm	290/****	301/****	301H/****
Track Curves	For single doors x1 or for bi-parting doors x2	600K	600B	600BH
Brackets Fix every 900mm max. and at track joints and curves. Fix jointing brackets/sleeve at both curved ends.	Face fixed bracket, single	1A/290	1A/301	1A/301
	Face fixed bracket, single jointing	1AX/290	1AX/301	1AX/301
	Face fixed bracket, jointing	-	4RX/301TS	4RX/301TS
	End clip	1A/290EC	1A/301EC	1A/301EC
Hangers 1 per door joint and end door	Intermediate hanger	62K	62A	62A
	End hanger	63K	63A	63A
Hinges 3 in height	Backflap hinge	65	65	65
Guides 1 per door joint and end door	Intermediate guide	67/89	67/97	67/97
	Spindle	67/89SP	67/97SP	67/97SP
	End Guide	68/89	68/97	68/97
Channel	Galvanised steel channel - 2000, 2500, 3000, 4000 and 6000mm lengths (89 and 100 channel not available in 6000mm)	89/****	97/****	100/****
Channel Curve	Galvanised steel channel curve	601/89	601/97	601/100
Stops	Zinc plated steel door stop with single rubber buffer	109	109	109
	Zinc plated steel door stop with double rubber buffer	107	107	107

**** Replace by length of track for full short code.

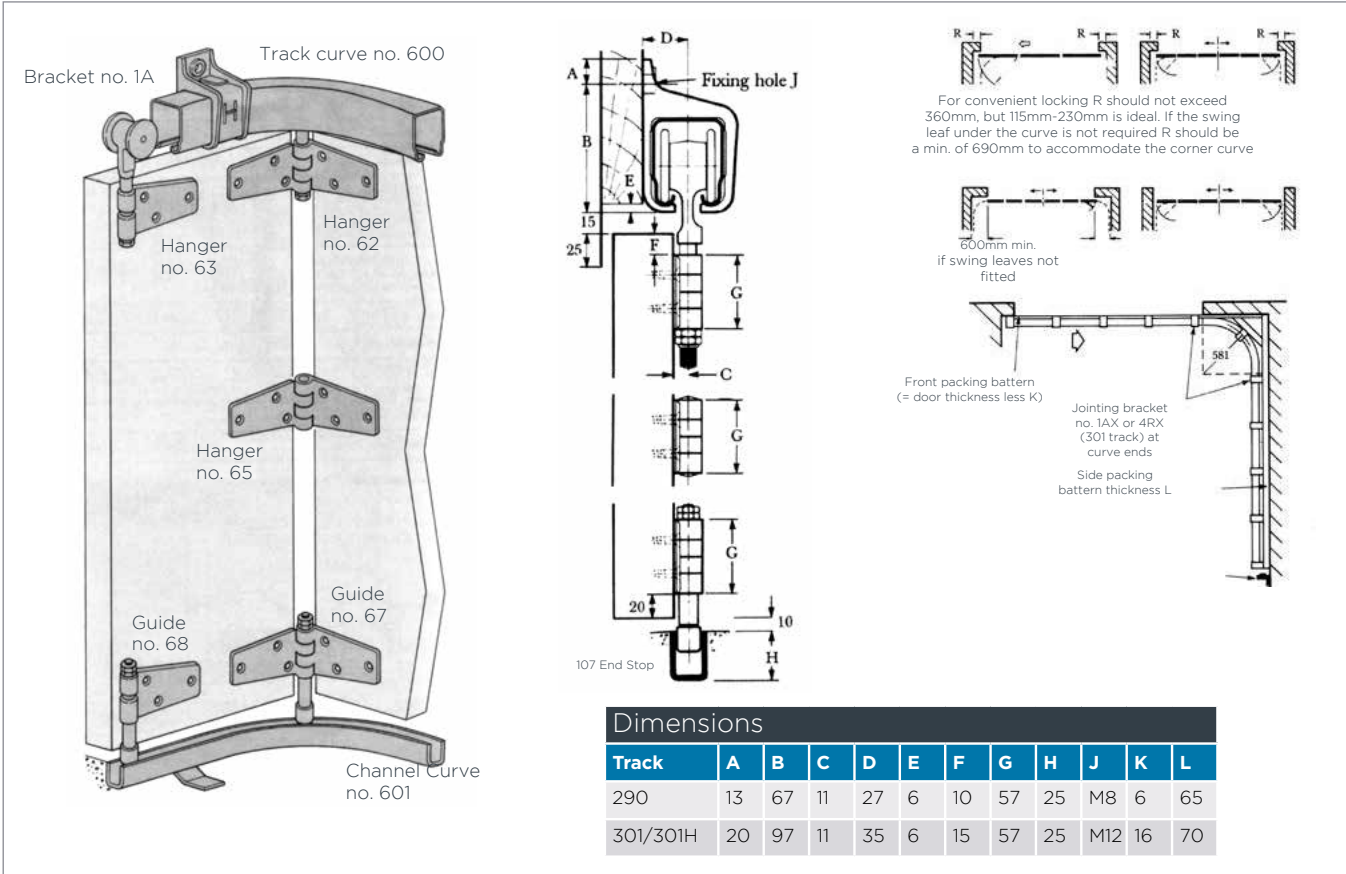

Bracket no. 1A
Track curve no. 600
Hanger no. 62
Hanger no. 63
Hanger no. 65
Guide no. 67
Guide no. 68
Channel Curve no. 601

Dimensions

Track	A	B	C	D	E	F	G	H	J	K	L
290	13	67	11	27	6	10	57	25	M8	6	65
301/301H	20	97	11	35	6	15	57	25	M12	16	70

For convenient locking R should not exceed 360mm, but 115mm-230mm is ideal. If the swing leaf under the curve is not required R should be a min. of 690mm to accommodate the corner curve

600mm min. if swing leaves not fitted

Front packing battens (= door thickness less K)

Joining bracket no. 1AX or 4RX (301 track) at curve ends

Side packing battens thickness L

107 End Stop

Hardware

Track



290

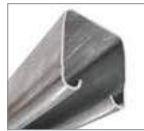

301



301H

Track Curves



600K



600B



600BH

Brackets



1A



1AX

Brackets



4RX



1A/**EC

Hangers



62K



63K



62A



63A

Hinge



65

Guides



67

Guides



67/**SP



68

Channel



89



97



100

Channel Curve



601

Stops



109



107

Accessories



Cast Iron Bow Handle 159 x 46mm (463)



Cast Iron Bow Handle 261 x 62mm (464)



Roller Bolt 380mm for 89 Channel (994R/89)



Roller Bolt 380mm for 97 Channel (994R/97)



Galvanised Steel Offset Shoot Bolt (994X)

View our full range of accessories on page 136



Automated



Evolve is an exceptionally convenient and highly sophisticated range of automatic sliding systems that can be used in any domestic or light commercial environment.

Designed to further enhance our sliding range of products, Evolve features a built in system that enables sliding doors to open at the push of a button, remote control or by activation of a movement sensor.

Available to cater for single doors, bi-parting doors and pocket doors - the system offers the utmost in ease and sophistication as well as being an ideal solution for those living with mobility access needs.

Range Overview

- Catering for maximum door weights of up to 80kg
- Sliding doors open at the push of a button, remote control or by activation of a movement sensor
- Available in single, bi-parting or pocket door configurations
- Suitable for wooden, metal and glass doors
- Interior applications

EVOLVE

Automated sliding system for wooden, metal or glass doors weighing up to 80kg



Our automated Evolve system incorporates our popular Soltaire 120 system. The result is an exceptionally smooth and reliable automated system which can cater for single doors or two bi-parting doors with simultaneous action.

Sliding doors can open at the push of a button, remote control or by activation of a movement sensor - offering the utmost in sophistication and convenience.

Evolve is an ideal solution to improve mobility access or add a sophisticated feature to a home or light commercial application. Evolve comes complete with track, hangers, floor guide, track stops, automation kit and two wall mounted control panels as standard. A number of sophisticated optional extras are available that can add to the refinement of the product.

Product Information

Short Code	No. of Doors	Door Material	Track Length	Door/Glass Thickness Range	Min. Door Width	Max. Door Width	Clear Opening	Max. Door Weight	
E80/20	1	Wood/Metal	2000mm	30 - 50mm*	675mm	1100mm	1020mm	80kg	
E80/30			3000mm		675mm	1600mm	1520mm		
10/E80/20		Glass	2000mm	10mm	760mm	1100mm	1020mm		
10/E80/30			3000mm		760mm	1600mm	1520mm		
12/E80/20			2000mm	12mm	760mm	1100mm	1020mm		
12/E80/30					3000mm	760mm	1600mm		1520mm
ESIM80/40	2 Bi-Parting	Wood/Metal	4000mm (2 x 2000mm)	30 - 50mm*	675mm	1058mm	2035mm	40kg (per door)	
10/E80SIM/40		Glass			10mm	760mm	1058mm		2035mm
12/E80SIM/40					12mm	760mm	1058mm		2035mm

*A spacer is required to accommodate doors over 40mm thick in a wooden door face fixed application

Kit Contents

Component	Short Code
Track (x1)	120/****
Hangers or Glass Clamps	51/120/SS or Glass Clamps
Floor Guide	10ISS or 8-12/SN
Track Stops	HH4/AN
Toothed Belt	-
Belt Clamp	-
Tensions Wheel	-
Face Fixed Brackets	-
Motor (1.5m cable length)	-
24V Transformer	-

Drive Unit Specification

Specification	Detail
Operation Voltage:	24V safety - low voltage via external power unit
Maximum Operating Speed (door weight dependent)	Up to 80kg - 20cm/s max speed Up to 60kg - 23cm/s max. speed Up to 40kg - 26cm/s max. speed
Running Performance:	Soft start and stop
Safety Function:	Includes obstacle detection in both directions
Configurable Options:	Push and go, closing speed, auto closing delay timer can all be configured to user preference

Accessories

Remote Control Kit **(E2/RCK)**
Includes a single channel remote control and one wireless receiver control panel

Radar Motion Sensor **(ER/*)**
Available in black (ER/B), white (ER/W) or aluminium (ER/S)

View our full range of accessories on page 136

Wooden or Metal Door Application

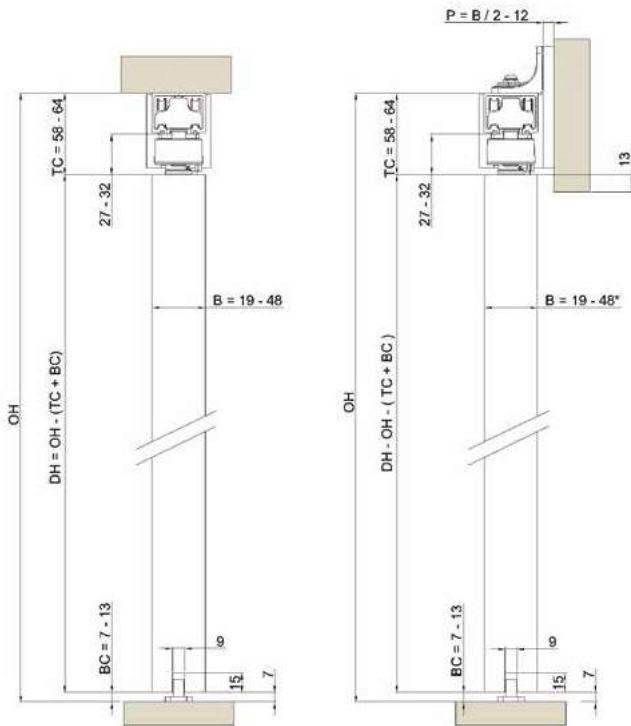

Glass Door Application

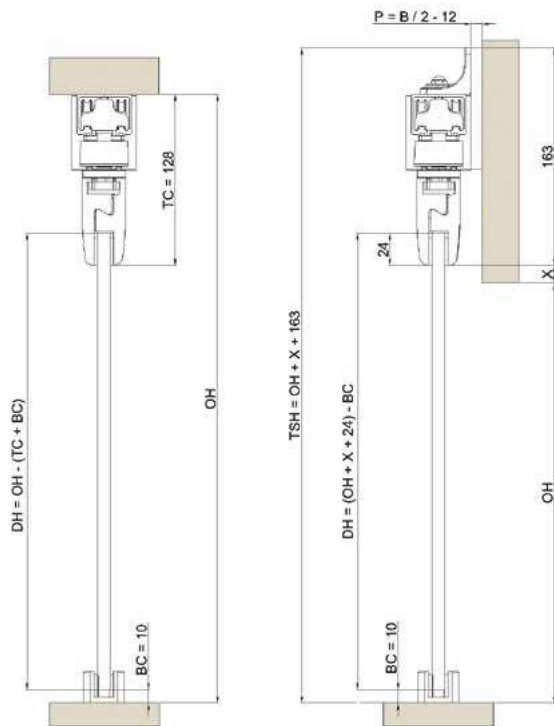

For metal doors, suitable fixings must be used.

Single Door Application

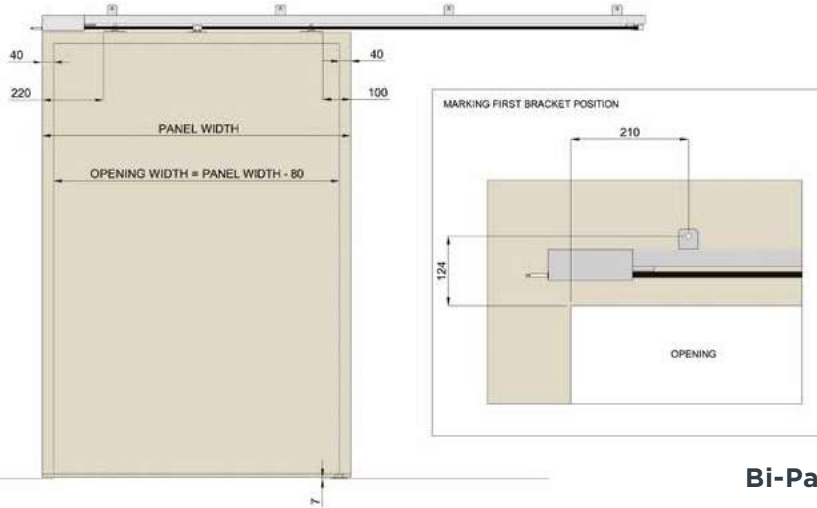

Bi-Parting Door Application

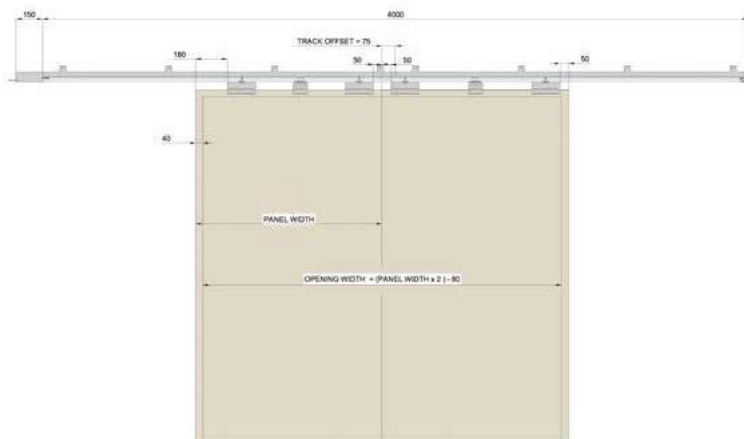

EVOLVE POCKET DOOR PRO

Automated sliding system for wooden pocket doors weighing up to 80kg



Evolve Pocket Door Pro is a professional hardware solution that allows doors to automatically slide into a cavity wall. Designed with a high quality, aluminium cavity frame, the system is extremely robust. Catering for residential and light commercial applications, the system is ideal for rooms where space is limited such as bathrooms, ensuites or kitchens as well as being used to improve mobility access.

The aluminium cavity frame comes with push together parts for easy and rapid installation. The system is available in seven different kit sizes, which can also be cut to size, and for finished wall thickness's of 120mm or 125mm.

Sliding doors can open at the push of a button, remote control or by activation of a movement sensor - offering the utmost in sophistication and convenience. The systems comes with two wall mounted control panels as standard.

Available accessories include a timber liner kit for a professional finish, as well as a number of sophisticated optional extras that can add to the refinement of the product.

For bi-parting automated pocket doors, two kits can be used.

Product Information

Short Code	Track Length	Max. Door Width	Max. Door Height	Door Thickness	Max. Weight	Finished Wall Thickness
EVOPRO1/**	1250mm	610mm	1981mm	35 - 44mm	80kg	120mm or 125mm
EVOPRO2/**	1402mm	686mm	1981mm	35 - 44mm	80kg	120mm or 125mm
EVOPRO3/**	1554mm	762mm	1981mm	35 - 44mm	80kg	120mm or 125mm
EVOPRO4/**	1706mm	838mm	1981mm	35 - 44mm	80kg	120mm or 125mm
EVOPRO6/**	1682mm	826mm	2040mm	35 - 44mm	80kg	120mm or 125mm
EVOPRO7/**	1482mm	726mm	2040mm	35 - 44mm	80kg	120mm or 125mm
EVOPRO10/**	1890mm	930mm	2315mm	35 - 44mm	80kg	120mm or 125mm

*** For full short code replace with required finished wall thickness - 120 or 125 (mm)

Finished Wall Thickness Calculation

120mm Finished Wall Thickness

95mm cavity + 12.5mm plasterboard either side = 120mm finished wall thickness

125mm Finished Wall Thickness

100mm cavity + 12.5mm plasterboard either side = 125mm finished wall thickness

Drive Unit Specification

Specification	Detail
Operation Voltage:	24V safety - low voltage via external power unit
Maximum Operating Speed (door weight dependent)	Up to 80kg - 20cm/s max speed Up to 60kg - 23cm/s max. speed Up to 40kg - 26cm/s max. speed
Running Performance:	Soft start and stop
Safety Function:	Includes obstacle detection in both directions
Configurable Options:	Push and go, closing speed, auto closing delay timer can all be configured to user preference

Kit Contents

- Aluminium Track (x1)
- Aluminium Upright (x4)
- Hangers (x2)
- Floor Guide (x1)
- Fixing Plate (x4)
- Header Fixing Bracket (x8)
- Door Stop (x1)
- Noggin c/w Fixing Block (x2)
(x4 for PDKPRO10)
- Floor Bracket (x2) (x4 for PDKPRO10)
- Tie Back & Fixing Block (x4) (PDKPRO10)
- Motor (1.5m cable length)
- Toothed Belt
- Belt Clamp
- Tension Wheel
- 24V Transformer
- Wall Mounted Control Panels (x2)
- Screws

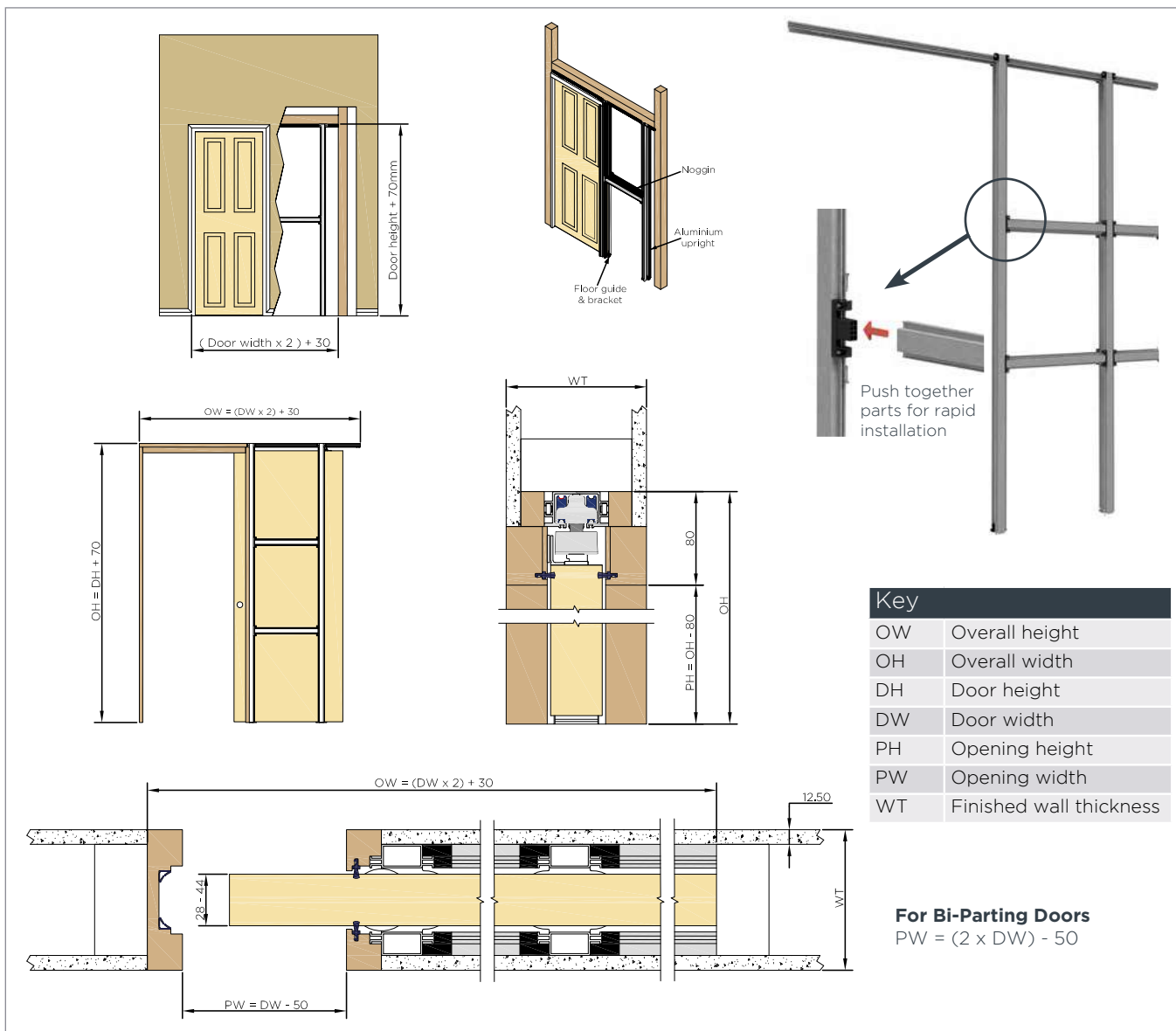

Opening Size Guide

Kit	Max. Passage Width (W x H)	Overall Dimensions (W x H)	Cavity Thickness	Finished Wall Thickness (FWT)
EVOPRO1/**	560mm x 1971mm	1250mm x 2051mm	95mm or 100mm	120mm or 125mm
EVOPRO2/**	636mm x 1971mm	1402mm x 2051mm	95mm or 100mm	120mm or 125mm
EVOPRO3/**	712mm x 1971mm	1554mm x 2051mm	95mm or 100mm	120mm or 125mm
EVOPRO4/**	788mm x 1971mm	1706mm x 2051mm	95mm or 100mm	120mm or 125mm
EVOPRO6/**	776mm x 2030mm	1682mm x 2110mm	95mm or 100mm	120mm or 125mm
EVOPRO7/**	676mm x 2030mm	1482mm x 2110mm	95mm or 100mm	120mm or 125mm
EVOPRO10/**	880mm x 2305mm	1890mm x 2385mm	95mm or 100mm	120mm or 125mm

Accessories

NEW
Bi-parting
liner kit,
available
Summer
2020



Liner Kit for Single doors (LK/**)



Liner Kit for Bi-Parting doors (BILK/**)



Remote Control Kit (E2/RCK)
Includes a single channel remote control and one wireless receiver control panel



Radar Motion Sensor (ER/*) available in black, white or aluminium



Round Flush Pull Set (385/S) satin, also available in chrome, polished brass and black



Square Flush Pull Set (53/S) satin, also available in chrome and black



Rectangle Flush Pull (125/S) satin, also available in chrome

*** For full short code please replace with required finished wall thickness size - 120 or 125 (mm)
*For full short code replace with required colour

View our full range of accessories on page 136



Shutters



Shutter Slide is a high performing range of straight sliding hardware systems for the movement of louvre panels in residential and commercial applications.

With climates changing and an ever increasing demand for environmental and LEED accredited specifications, P C Henderson is pleased to introduce a new range of sliding louvre hardware systems to the market. Louvre systems offer many benefits such as retaining heat from the sun to heat a building as well as being used to trap heat within a building when used with the correct insulation panels. The system can also aid towards light reduction, sound insulation, flexible privacy options as well as the ability to enhance a facades architectural aesthetic appearance.

The system is available for doors weighing up to 120kg, in single panel, bi-parting and telescopic panel variants - as well as being available in either manual or automated operation.

Range Overview

- Catering for maximum door weights of up to 120kg
- Available in single panel, bi-parting and telescopic panel variants
- Manual or automated operation
- Manufactured from 316 marine grade stainless steel

SHUTTER SLIDE

NEW

Straight sliding hardware for the movement of manual and automatic louvre panels



Shutter Slide is a high performing straight sliding shutter system, suitable for residential and commercial applications. The highly flexible system can cater for wooden and metal external louvre panels and shutters weighing up to 120kg.

Offering a variety of inspiring and functional design possibilities, the system is available as single panel; simultaneous action panel or telescopic panel variants. All systems are available for either manual or automatic operation.

Manufactured from 316 marine grade stainless steel, hard wearing polymers and anodised aluminium, the system is extremely robust, highly corrosion resistant and developed to ensure a long lifespan.

Wind load testing should be carried out based on a projects individual requirements.

Available in 24V or 230V options our state of the art motors can be operated by the push of a button or remote control. Alternatively the motors can be wired into the central control panel of a building, please consult the P C Henderson technical team for details.

Product Information

Configuration	Min. Panel Width	Max. Panel Height	Panel Thickness Range	Max. System Width	Max. Panel Weight	
					Manual	Automated
Single Panel (1 panel)	400mm	3000mm	35 - 50mm	6000mm	120kg	120kg
Simultaneous Action (2 panels)	400mm	3000mm	35 - 50mm	6000mm	120kg	60kg
Telescopic (2 panels)	400mm	3000mm	35 - 47mm	6000mm	120kg	80kg
Telescopic (3 panels)	400mm	3000mm	35 - 47mm	6000mm	120kg	60kg

Accessories



Face Fixed Double Bracket **(5/SS)**
Stainless Steel



Face Fixed Bracket **(1/SS)**
Stainless Steel



Wall Mounted Guide **(102SS/94)**



Remote Control Kit **(E2/RCK)**

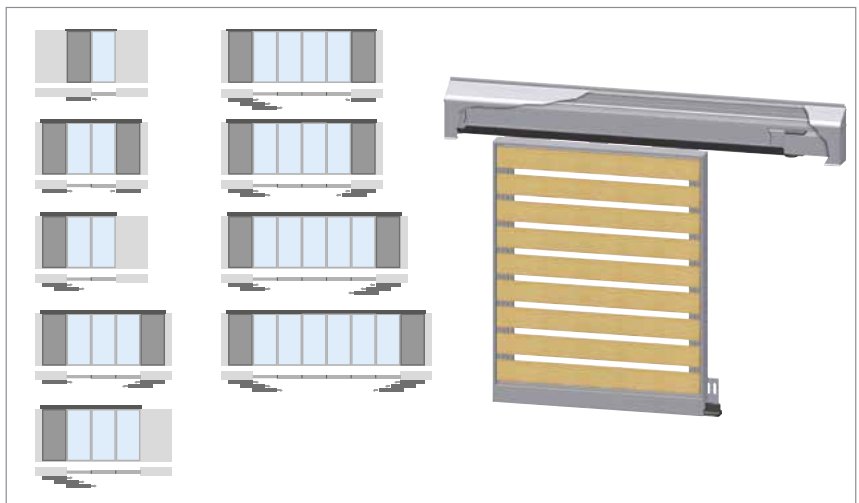

Product Specification

Component	Description	Single Panel & SIM	Telescopic (2 doors, 2 tracks)	Telescopic (3 doors, 3 tracks)
Track	Anodised aluminium track in 2000, 2500, 3000, 3500, 4000, 5000 and 6000mm lengths	120/****		
Hanger	Top fixed, surface mounted hanger for wooden and metal panels	51/120/SS		
	Angle frame hanger for metal louvre panels	56/120/SS		
Wall Fixing Profile	Wall fixing profile in 2000, 2500, 3000, 4000 and 6000mm lengths	WP50T/****	WP100T/****	WP150T/****
Fascia and Endcaps	Fascia for wall fixing profile in 2000, 2500, 3000, 4000 and 6000mm lengths	WP50F/****	WP100F/****	WP150F/****
	Endcaps for fascia	WP50/EC	WP100/EC	WP150/EC
Channels	U profile channel with gasket -2000, 3000, 4000 & 6000mm	GSSUR/****		
	U profile channel with L channel and gasket in 2000, 3000, 4000 and 6000mm lengths	GSSULR/****		
	Anodised aluminium support channel in 2000, 2500, 3000, 3500, 4000, 5000 and 6000mm lengths	94SC/****		
	Polypropylene channel in 2000, 2500, 3000, 3500, 4000, 5000 and 6000mm lengths	94P/****		
Fixing Plates	L plate available in 40, 60 and 100mm lengths	GSS/MK**		
	Offset angle plate - left hand - 100mm length (can be cut down)	GSS/LH		
	Offset angle plate - right hand - 100mm length (can be cut down)	GSS/RH		
Bottom Guides	Guide to be used with GSS/MK L plate - wide base (10mm depth)	GSS/SBK10		
	Guide to be used with GSS/MK L plate - narrow base (10mm depth)	GSS/SSK10		
	Black nylon guide, floor mounted or panel mounted (4mm depth)	GSS/SL		
	Concealed guide	106SS/94		
Stop	Track stop	HH4/AN		
Telescopic Set	Telescopic set for two or three panels	-	E/TEL2	E/TEL3

**** Replace with required length for full short code

**Replace with required length of depth for full short code

Automation Specification - must be specified when creating an automated system

Component	Description	Single Panel & SIM	Telescopic (2 doors, 2 tracks)	Telescopic (3 doors, 3 tracks)
Motor (can carry up to 3 shutters in one direction)	24V motor with two wall mounted control panels	E120/24V		
	230V motor - control panel built within motor	E120/230V		
Belt, Clamp and Pulley	Belt 10mm (per metre)	E/B10		
	Clamp - 10mm	E/CL10		
	Pulley wheel	E/PA10		
Accessories	Remote control kit (for use with 24V motor only)	E2/RCK		

Hardware

 120	 51/120/SS	 56/120/SS	 WP**T	 WP**F	 WP**/EC	 GSSUR	 GSSULR
 94SC	 94P	 GSS/MK**	 GSS/LH	 GSS/RH	 GSS/SBK10	 GSS/SSK10	 GSS/SL
 106SS/94	 HH4/AN	 E/TEL*/	 E120/****V	 E/B10	 E/CL10	 E/PA10	 E2/RCK

Folding Door Configurations and Quantities

Folding Doors

Folding door units consist of a number of wooden or aluminium doors hinged together. Wide units usually slide and fold in two parts, to the right and left. Extra wide openings should be covered by three or more units with the centre units floating.

Brackets

For information on bracket positioning please check the product datasheet which can be viewed on our website.

Track

Select the track according to the height or weight of a door.



Fittings

Having selected the track, extract the fittings and quantities shown in the relative column. Side wall or soffit fixed brackets are available.

NOTE: Securefold door configurations can be found on page 99 and 100 and Securefold Bottom Rolling door configurations can be found on page 84.

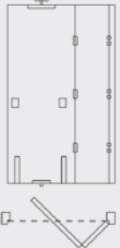
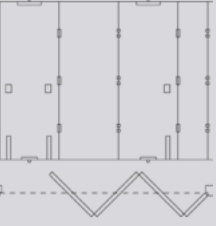

Interior Centre Folding Systems

Configuration	Item	Quantity	Component		
			2700mm Max. Door Height or 35kg Max. Door Weight	2700mm Max. Door Height or 75kg Max. Door Weight	4500mm Max. Door Height or 125kg Max. Door Weight
1.5 LEAF Centre folding hinged to post 	Track	-	600	600	550
	Brackets	See page 120	1B	1B	1A/550 or 3S/550
	Hanger	1	61B	61B/4	556/61
	Hinges	6*	403 (89x50)	403 (100x55)	403 (100x75)
	Guide	1	106N	106N	106N
	Channel	-	94 or 94X	94 or 94X	94 or 94X
	Flushpull	4	400	400	400
	Flushbolt	2	SF190/450/600 or F3715 and F3734	SF190/450/600 or F3715 and F3734	SF190/450/600 or F3715 and F3734
3.5 LEAF Centre folding hinged to post 	Track	-	600	600	550
	Brackets	See page 120	1B	1B	1A/550 or 3S/550
	Hanger	2	61B	61B/4	556/61
	Hinges	12*	403 (89x50)	403 (100x55)	403 (100x75)
	Guide	2	106N	106N	106N
	Channel	-	94 or 94X	94 or 94X	94 or 94X
	Flushpull	6	400	400	400
	Flushbolt	3	SF190/450/600 or F3715 and F3734	SF190/450/600 or F3715 and F3734	SF190/450/600 or F3715 and F3734
5.5 LEAF Centre folding hinged to post 	Track	-	600	600	550
	Brackets	See page 120	1B	1B	1A/550 or 3S/550
	Hanger	3	61B	61B/4	556/61
	Hinges	18*	403 (89x50)	403 (100x55)	403 (100x75)
	Guide	3	106N	106N	106N
	Channel	-	94 or 94X	94 or 94X	94 or 94X
	Flushpull	8	400	400	400
	Flushbolt	4	SF190/450/600 or F3715 and F3734	SF190/450/600 or F3715 and F3734	SF190/450/600 or F3715 and F3734
5 LEAF Centre folding - floating 	Track	-	600	600	550
	Brackets	See page 120	1B	1B	1A/550 or 3S/550
	Hanger	3	61B	61B/4	556/61
	Hinges	12*	403 (89x50)	403 (100x55)	403 (100x75)
	Guide	3	106N	106N	106N
	Channel	-	94 or 94X	94 or 94X	94 or 94X
	Flushpull	4	400	400	400
	Flushbolt	2	SF190/450/600 or F3715 and F3734	SF190/450/600 or F3715 and F3734	SF190/450/600 or F3715 and F3734

*For doors exceeding 3000mm high increase to 8

*For doors exceeding 3000mm high increase to 16

*For doors exceeding 3000mm high increase to 24

*For doors exceeding 3000mm high increase to 16

Interior End Folding Systems

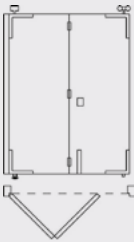
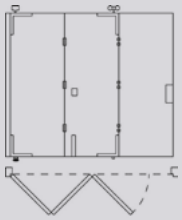
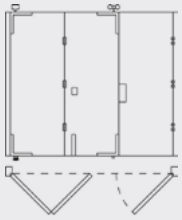
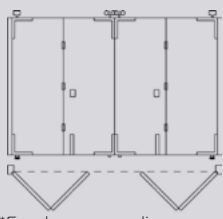
Configuration	Item	Quantity	Component	
			2700mm Max. Door Height or 35kg Max. Door Weight	4500mm Max. Door Height or 35kg Max. Door Weight
2 LEAF Folding to the left 	Track	-	600	550
	Brackets	See page 120	1B	3S/550
	Hanger	1	21B	556/21
	Pivot	1	21B/P	21/550P
	Hinges	3*	403 (89x50)	403 (100x75)
	Guide	1	21N/94	21R/94
	Channel	-	94 or 94X	94 or 94X
	Flushpull	2	400	400
	Flushbolt	1	SF190/450/600 or F3715 and F3734	SF190/450/600 or F3715 and F3734
	Lock and handles	1	-	-
3 LEAF With swinger folding to the left 	Track	-	600	550
	Brackets	See page 120	1B	3S/550
	Hanger	1	21B/4	556/21
	Pivot	1	21B/P	21/550P
	Hinges	6*	403 (89x50)	403 (100x75)
	Guide	1	21N/94	21R/94
	Channel	-	94 or 94X	94 or 94X
	Flushpull	2	400	400
	Flushbolt	2	SF190/450/600 or F3715 and F3734	SF190/450/600 or F3715 and F3734
	Lock and handles	1	-	-
3 LEAF 2 folding to the left, 1 swinger hinged to post 	Track	-	600	550
	Brackets	See page 120	1B	3S/550
	Hanger	1	21B	556/21
	Pivot	1	21B/P	21/550P
	Hinges	6*	403 (89x50)	403 (100x75)
	Guide	1	21N/94	21R/94
	Channel	-	94 or 94X	94 or 94X
	Flushpull	-	400	400
	Flushbolt	1	SF190/450/600 or F3735	SF190/450/600 or F3735
	Lock and handles	1	-	-
4 LEAF 2 folding to each side 	Track	-	600	550
	Brackets	See page 120	1B	3S/550
	Hanger	2	21B	556/21
	Pivot	2	21B/P	21/550P
	Hinges	6*	403 (89x50)	403 (100x75)
	Guide	2	21N/94	21R/94
	Channel	-	94 or 94X	94 or 94X
	Flushpull	4	400	400
	Flushbolt	2	SF190/450/600 or F3715 and F3734	SF190/450/600 or F3715 and F3734
	Lock and handles	1	-	-

Interior End Folding Systems

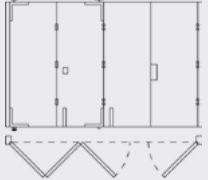
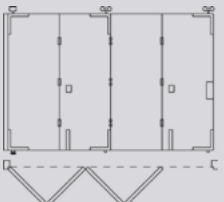
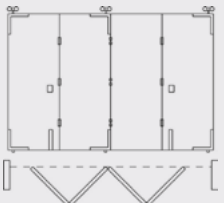
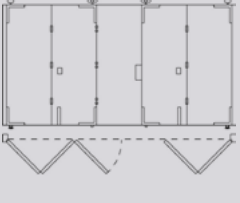
Configuration	Item	Quantity	Component		
			2700mm Max. Door Height or 35kg Max. Door Weight	4500mm Max. Door Height or 35kg Max. Door Weight	
4 LEAF 3 with swinger to the left, 1 separate hinged to post 	Track	-	600	550	
	Brackets	See page 120	1B	3S/550	
	Hanger	1	21B/4	556/21	
	Pivot	1	21B/P	21/550P	
	Hinges	9*	403 (89x50)	403 (100x75)	
	Guide	1	21N/94	21R/94	
	Channel	-	94 or 94X	94 or 94X	
	Flushpull	2	400	400	
	Flushbolt	2	SF190/450/600 or F3715 and F3734	SF190/450/600 or F3715 and F3734	
	Lock and handles	1	-	-	
	4 LEAF Folding to the left 	Track	-	600	550
Brackets		See page 120	1B	3S/550	
Hanger		2	21B	556/21	
Pivot		1	21B/P	21/550P	
Hinges		9*	403 (89x50)	403 (100x75)	
Guide		2	21N/94	21R/94	
Channel		-	94 or 94X	94 or 94X	
Flushpull		4	400	400	
Flushbolt			SF190/450/600 or F3715 and F3734	SF190/450/600 or F3715 and F3734	
Lock and handles		1	-	-	
4 LEAF Floating 		Track	-	600	550
	Brackets	See page 120	1B	3S/550	
	Hanger	3	21B	556/21	
	Hinges	9*	403 (89x50)	403 (100x75)	
	Guide	3	21N/94	21R/94	
	Channel	-	94 or 94X	94 or 94X	
	Flushpull	4	400	400	
	Flushbolt	2	SF190/450/600 or F3715 and F3734	SF190/450/600 or F3715 and F3734	
	Lock and handles	1	-	-	
	5 LEAF 3 to the right with swinger, 2 to the left 	Track	-	600	550
Brackets		See page 120	1B	3S/550	
Hanger		2	21B	556/21	
Pivot		2			
Hinges		9*	403 89x50	403 100x75	
Guide		2	21N/94	21R/94	
Channel		-	94 or 94X	94 or 94X	
Flushpull		4	400	400	
Flushbolt		2	SF190/450/600 or F3715 and F3734	SF190/450/600 or F3715 and F3734	
Lock and handles		1	-	-	

Interior End Folding Systems

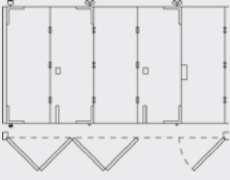
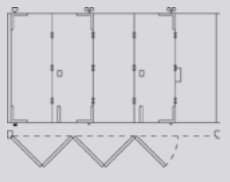
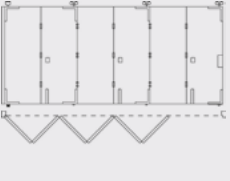
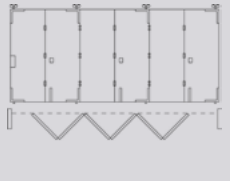
Configuration	Item	Quantity	Component		
			2700mm Max. Door Height or 35kg Max. Door Weight	4500mm Max. Door Height or 35kg Max. Door Weight	
5 LEAF 4 to the left, 1 separate swinger  <p>*For doors exceeding 3000mm high increase to 16</p>	Track	-	600	550	
	Brackets	See page 120	1B	3S/550	
	Hanger	2	21B	556/21	
	Pivot	1	21B/P	21/550P	
	Hinges	12*	403 (89x50)	403 (100x75)	
	Guide	2	21N/94	21R/94	
	Channel	-	94 or 94X	94 or 94X	
	Flushpull	4	400	400	
	Flushbolt	2	SF190/450/600 or F3715 and F3734	SF190/450/600 or F3715 and F3734	
	Lock and handles	1	-	-	
	5 LEAF With swinger  <p>*For doors exceeding 3000mm high increase to 16</p>	Track	-	600	550
Brackets		See page 120	1B	3S/550	
Hanger		2	21B	556/21	
Pivot		1	21B/P	21/550P	
Hinges		12*	403 (89x50)	403 (100x75)	
Guide		2	21N/94	21R/94	
Channel		-	94 or 94X	94 or 94X	
Flushpull		4	400	400	
Flushbolt		2	SF190/450/600 or F3715 and F3734	SF190/450/600 or F3715 and F3734	
Lock and handles		1	-	-	
6 LEAF Folding  <p>*For doors exceeding 3000mm high increase to 20</p>		Track	-	600	550
	Brackets	See page 120	1B	3S/550	
	Hanger	3	21B	556/21	
	Pivot	1	21B/P	21/550P	
	Hinges	15*	403 (89x50)	403 (100x75)	
	Guide	3	21N/94	21R/94	
	Channel	-	94 or 94X	94 or 94X	
	Flushpull	6	400	400	
	Flushbolt	3	SF190/450/600 or F3715 and F3734	SF190/450/600 or F3715 and F3734	
	Lock and handles	1	-	-	
	6 LEAF "Floating"  <p>*For doors exceeding 3000mm high increase to 20</p>	Track	-	600	550
Brackets		See page 120	1B	3S/550	
Hanger		4	21B	556/21	
Hinges		15*	403 (89x50)	403 (100x75)	
Guide		4	21N/94	21R/94	
Channel		-	94 or 94X	94 or 94X	
Flushpull		6	400	400	
Flushbolt		3	SF190/450/600 or F3715 and F3734	SF190/450/600 or F3715 and F3734	
Lock and handles		1	-	-	

Interior End Folding Systems

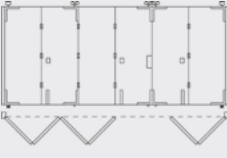
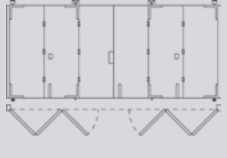
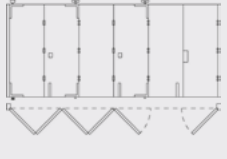
Configuration	Item	Quantity	Component	
			2700mm Max. Door Height or 35kg Max. Door Weight	4500mm Max. Door Height or 35kg Max. Door Weight
6 LEAF 4 folding to the left, 2 folding to the right 	Track	-	600	550
	Brackets	See page 120	1B	3S/550
	Hanger	3	21B	556/21
	Pivot	2	21B/P	21/550P
	Hinges	12*	403 (89x50)	403 (100x75)
	Guide	3	21N/94	21R/94
	Channel	-	94 or 94X	94 or 94X
	Flushpull	6	400	400
	Flushbolt	3	SF190/450/600 or F3715 and F3734	SF190/450/600 or F3715 and F3734
	Lock and handles	1	-	-
	*For doors exceeding 3000mm high increase to 16			
6 LEAF 3 with swinger to the left, 3 with swinger to the right 	Track	-	600	550
	Brackets	See page 120	1B	3S/550
	Hanger	2	21B	556/21
	Pivot	2	21B/P	21/550P
	Hinges	12*	403 (89x50)	403 (100x75)
	Guide	2	21N/94	21R/94
	Channel	-	94 or 94X	94 or 94X
	Flushpull	6	400	400
	Flushbolt	3	SF190/450/600 or F3715 and F3734	SF190/450/600 or F3715 and F3734
	Lock and handles	1	-	-
	*For doors exceeding 3000mm high increase to 16			
6 LEAF 5 with swinger to the left, 1 separate swinger 	Track	-	600	550
	Brackets	See page 120	1B	3S/550
	Hanger	2	21B	556/21
	Pivot	1	21B/P	21/550P
	Hinges	15*	403 (89x50)	403 (100x75)
	Guide	2	21N/94	21R/94
	Channel	-	94 or 94X	94 or 94X
	Flushpull	4	400	400
	Flushbolt	3	SF190/450/600 or F3715 and F3734	SF190/450/600 or F3715 and F3734
	Lock and handles	1	-	-
	*For doors exceeding 3000mm high increase to 20			

Component Drawings

Detailed drawings and dimensions of our range of commercial tracks, intersects, curves, brackets, hangers, pivot sets, guides, guide channels, accessories and stops. Industrial component drawings can be found on page 129.

Track, Intersect and Curve Drawings

280A Track

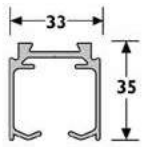

600 Track

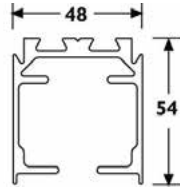

550 Track

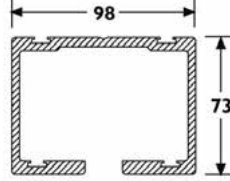

45R/550 Intersect (Top View)

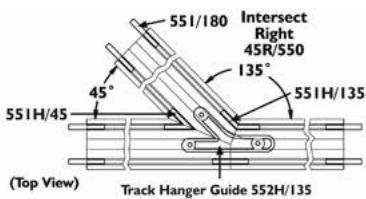

45L/550 Intersect (Top View)

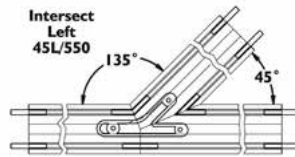

H135/550 Intersect (Top View)

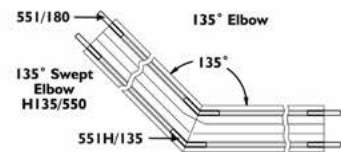

H90C/550 Intersect (Top View)

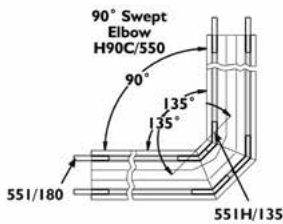

H90/550 Intersect

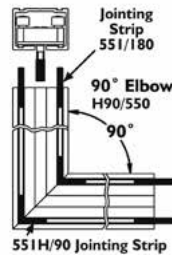

Intersect

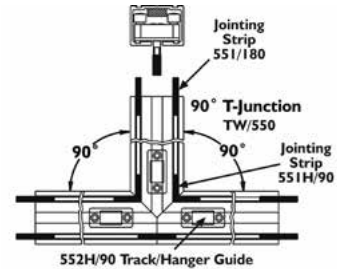

Bracket Drawings

1B

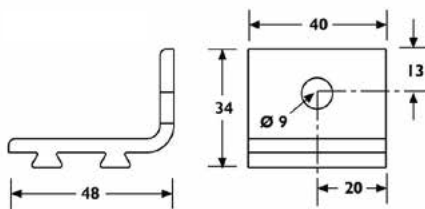

1BX

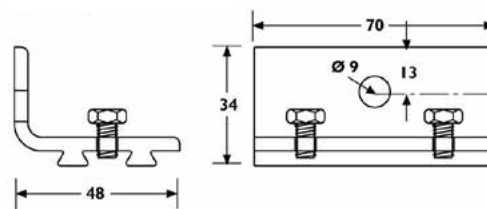

1A/550

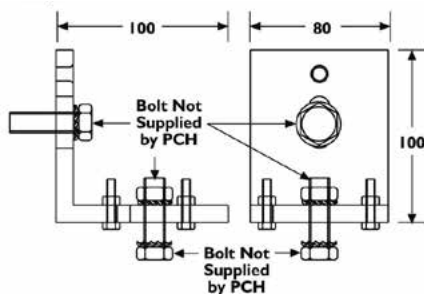

3S/550

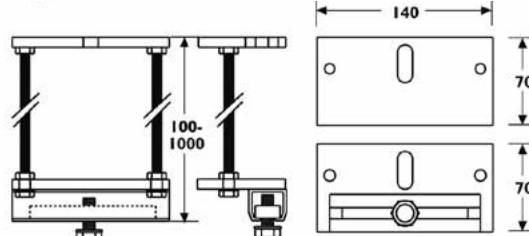

281AN

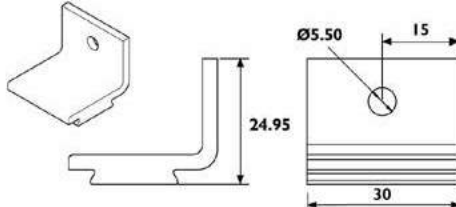

281AX

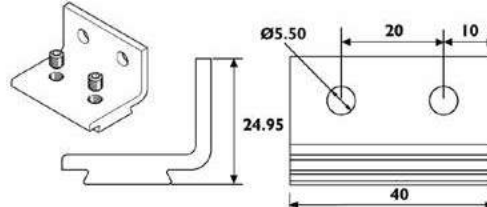

Hanger Drawings

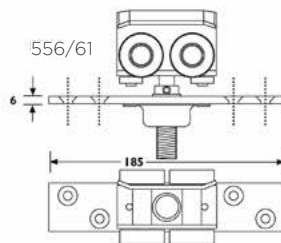
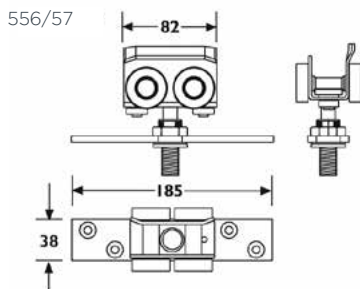
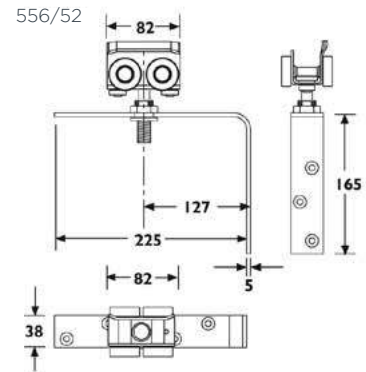
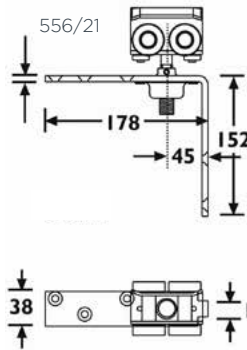
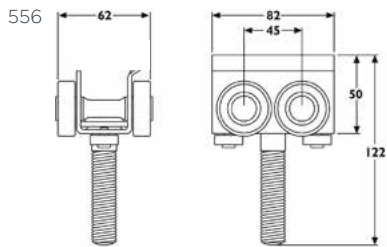
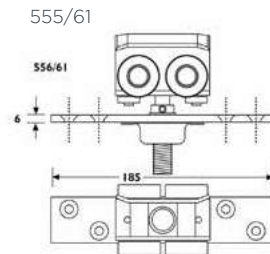
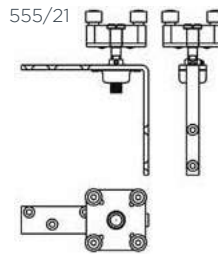
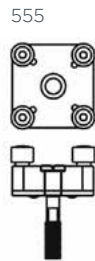
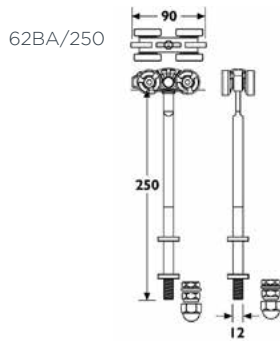
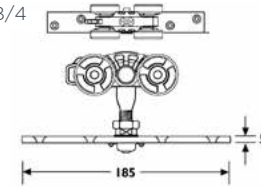
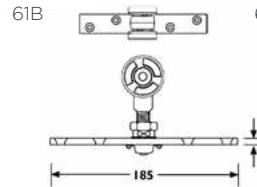
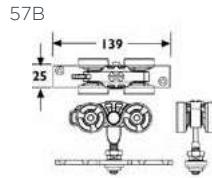
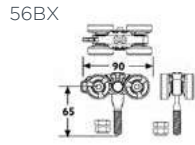
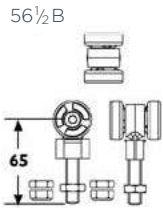
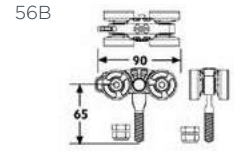
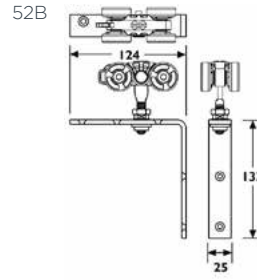
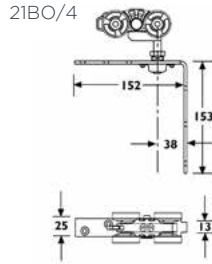
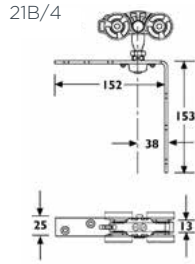
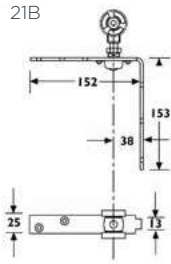

Pivot Set Drawings

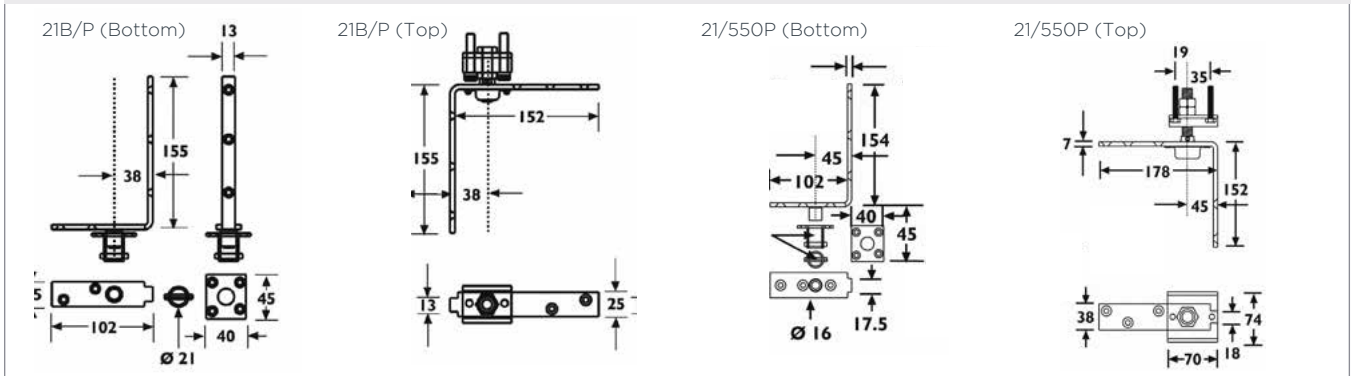

Guide Drawings

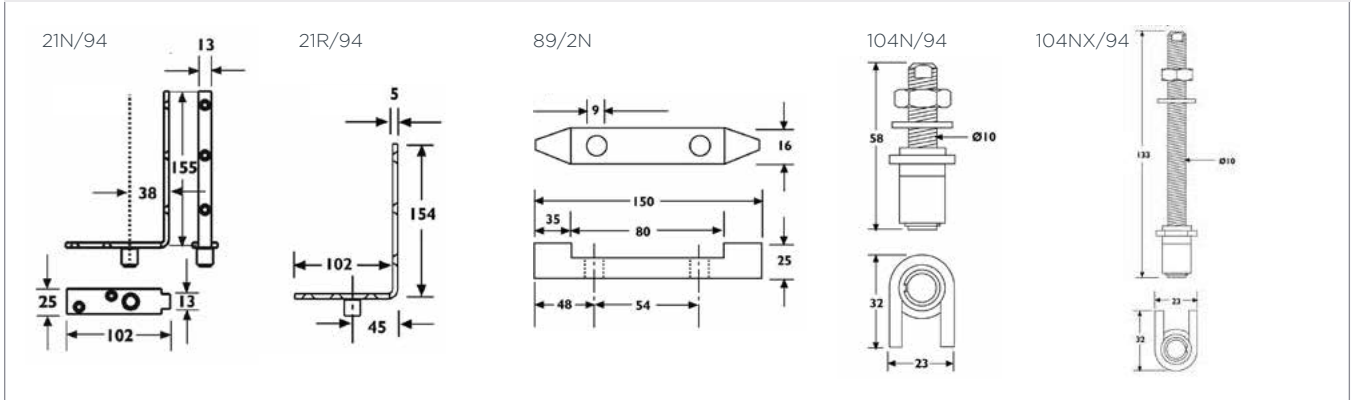

Guide Channel Drawings

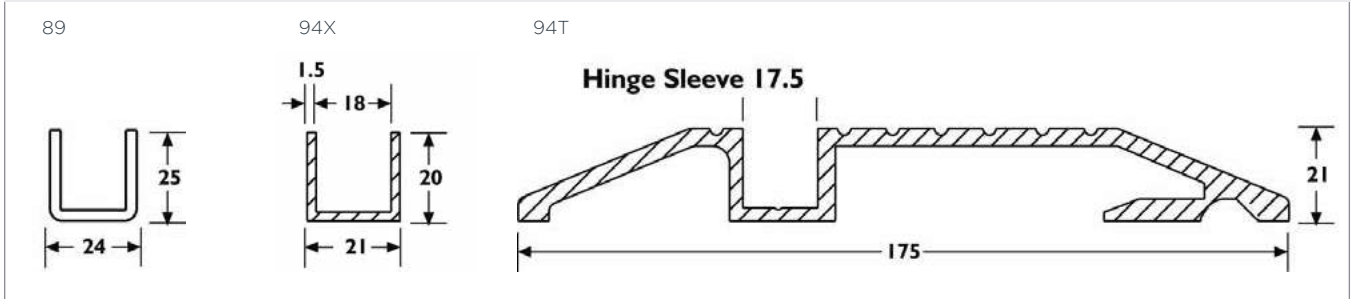

Accessories and Stops

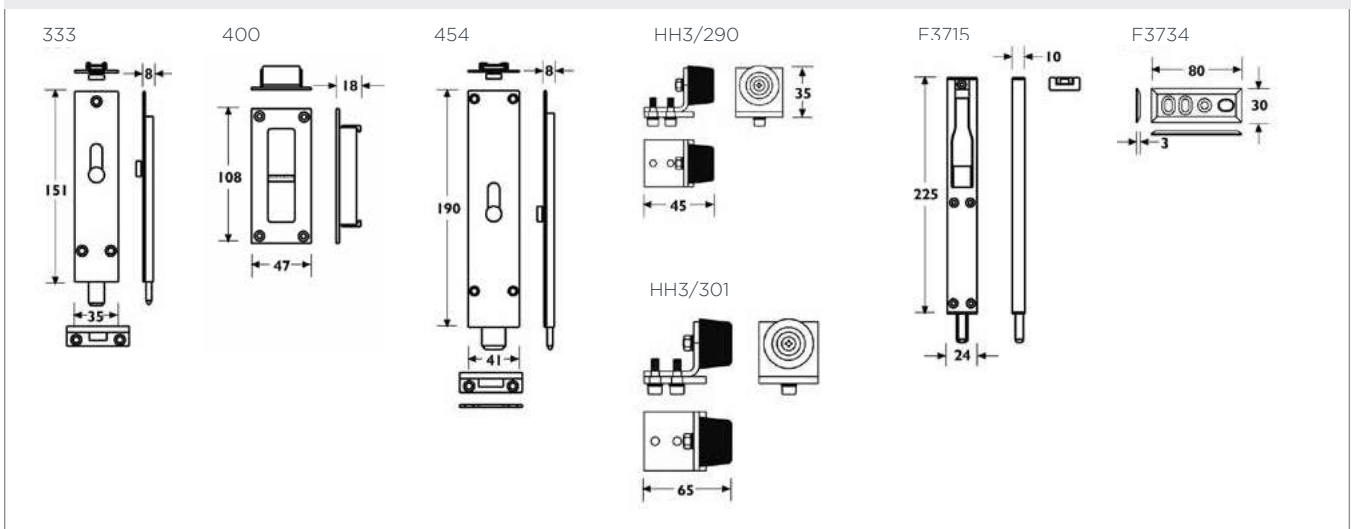

Industrial Component Drawings

Detailed drawings and dimensions of our range of industrial tracks, brackets, hangers, channels and rails.

Industrial products include:

- College Centrefold
- College Endfold
- Council Centrefold
- Council Endfold
- Majestic
- Mansion
- Overhead Runway Gear
- Sterling
- Straight Sliding
- Tangent Folding
- Tangent Round the Corner

Industrial Track Drawings

All of our industrial tracks are in a galvanised finish except for the 307 track which is zinc plated. Once installed, the tracks require minimal maintenance but should always be kept greased in order to reduce general wear and tear and to obtain the most optimum lifespan for the product. Any length of track can be obtained by simply putting sections of track together and fixing with a jointing bracket, complete with end clips or closed brackets at each end.

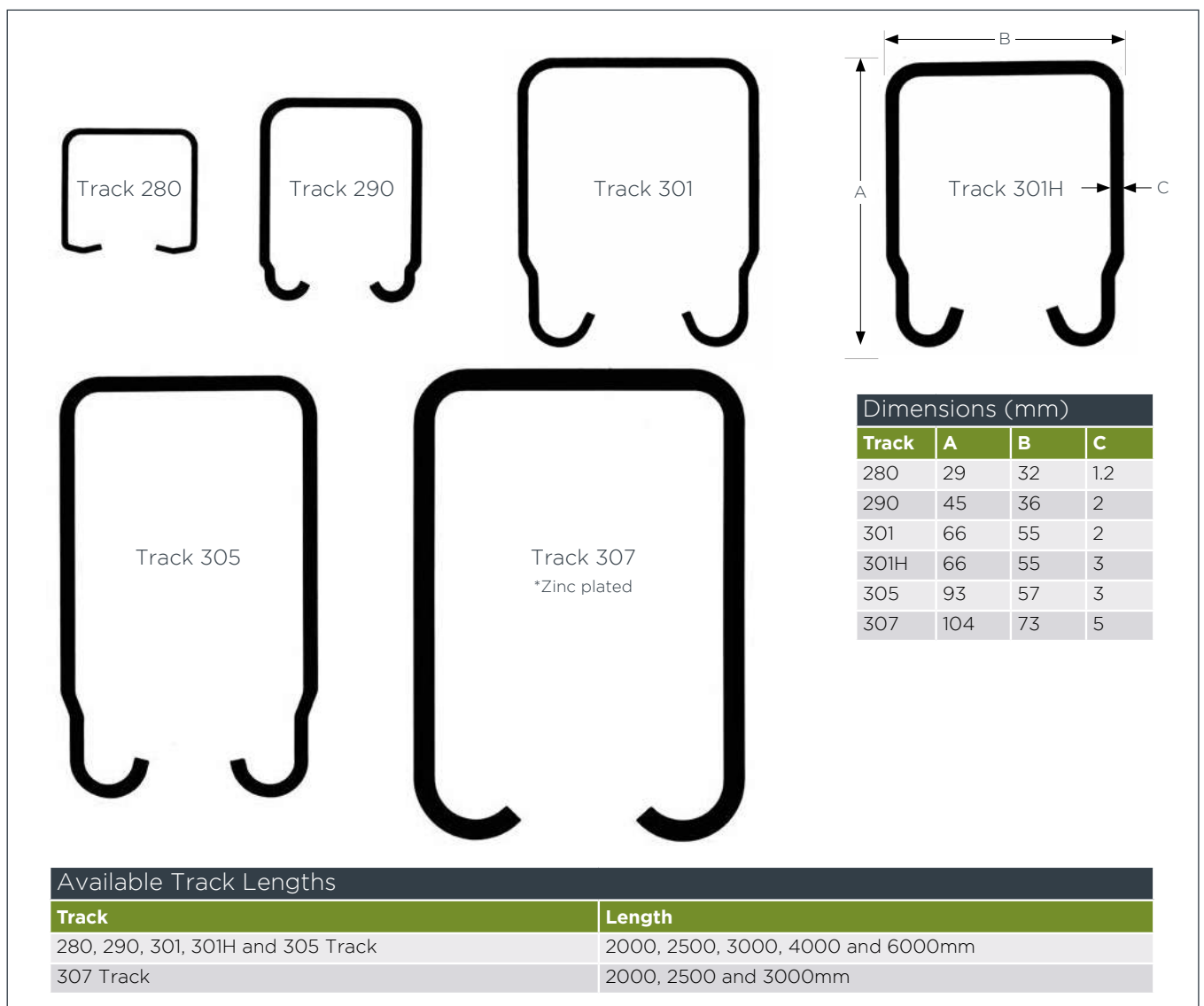

Industrial Bracket Drawings

All brackets are aluminium alloy die cast except where indicated with a suffix /S in the short code e.g. 1/301/S which are zinc plated steel. Ensure that closed brackets are fitted with an end-clip at track ends. Jointing brackets are required at each track joint and maximum bracket spacing is every 900mm.

Face Fixed

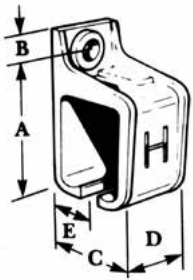

1 and 1A						
Short Code	Dimensions					Bolt
	A	B	C	D	E	
1A/290	67	13	52	32	27	M8
1/290/S	75	13	55	60	27	M8
1A/301	97	19	73	57	35	M12
1/301/S	95	16	69	60	37	M12
1A/305	140	25	85	76	38	M16
1/307/S	159	24	91	75	45	M16

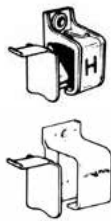

Note: Bracket End Clips 1A/290EC and 1A/301EC can be used in order to convert brackets 1, 1A, 3A, 4A, 5, 5AA and 6/301 to closed brackets (290, 301 and 301H formats only).

1/301/S steel bracket also accepts the 1A/301EC end clips.

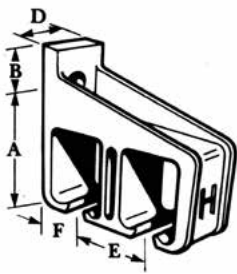

5						
Short Code	Dimensions					Bolt
	A	B	C	D	E	
5/290	80	20	38	54	27	M12
5/301	110	33	57	79	39	M16
5/305	155	38	75	92	48	M20
5/307/S	192	26	102	91	45	M20

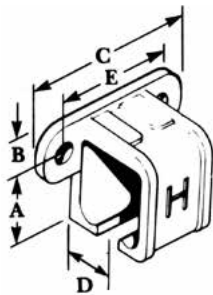

9 and 9A						
Short Code	Dimensions					Bolt
	A	B	C	D	E	
9A/290	43	16	70	24	51	14G Screw
9/301/S	65	12	125	38	89	18G Screw
9/305/S	84	38	160	59	130	M12
9/307/S	84	50	184	69	140	M16

Soffit Fixed

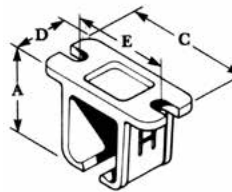

3 and 3A						
Short Code	Dimensions					Bolt
	A	B	C	D	E	
3A/290	56	-	83	32	64	M8
3A/301	86	-	130	57	100	M12
3/301/S	88	-	130	57	97	M12
3A/305	121	-	168	75	125	M16
3/307/S	158	-	184	90	140	M16

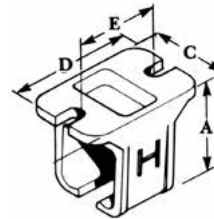

4 and 4A						
Short Code	Dimensions					Bolt
	A	B	C	D	E	
4A/290	67	-	48	75	60	M8
4A/301	95	-	75	117	95	M12
4A/305	137	-	83	190	130	M16
4/307/S	158	-	91	184	140	M16

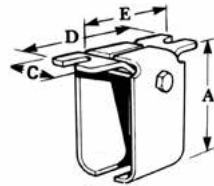

4/301/S						
Short Code	Dimensions					Bolt
	A	B	C	D	E	
4A/301/S	94	-	45	117	95	M12

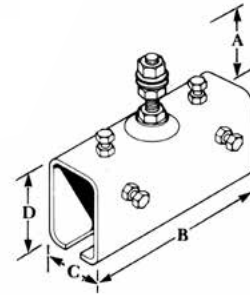

4R						
Short Code	Dimensions				Bolt	
	A	B	C	D		
4R/290/S	46	30	44	53	M10	
4R/301/S	66	57	65	78	M12	
4R/305/S	68	75	71	107	M16	
4RX/301TS	70	145	64	70	M12	

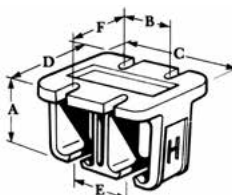

6							
Short Code	Dimensions					Bolt	
	A	B	C	D	E		
6/301	95	79	152	127	79	92	M10

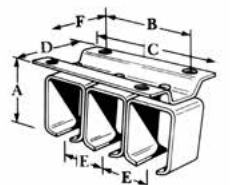

8							
Short Code	Dimensions					Bolt	
	A	B	C	D	E		
8/301/S	98	127	178	118	66	92	M12

Industrial Hanger Drawings

Our range of industrial hangers include both nylon wheeled (/N) and steel wheeled (/S) variants. Nylon wheels are more quiet and do not require the track to be greased, therefore allowing for a greater carrying capacity. For automatic doors, you will need to halve the carrying capacity and use nylon wheels if possible. Note: Door weight capacities are per pair of hangers.

Wood Doors

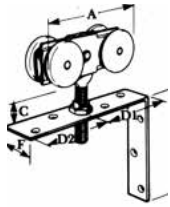

		52						
Track	Hanger Short Code	Dimensions						Max. Door Weight
		A	C	D1	D2	E	F	
290	52K/N							150kg
	52K/S	87	31	77	51	134	25	150kg
	52K/S 200							200kg
301 & 301H	52A/S	142	57	102	127	165	38	300kg
	52A/N							450kg
305	52C/S	161	61	102	127	165	38	700kg

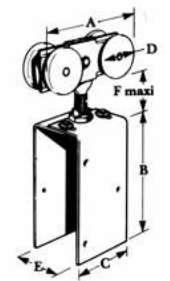

		53						
Track	Hanger Short Code	Dimensions						Max. Door Weight
		A	B	C	D	E	F	
290	53K/N							150kg
	53K/S	87	95	57	37	35-48	30	150kg
	53K/S 200							200kg
301	53A/S	142	178	76	56	43-57	71	300kg
	53A/N							400kg
301H	53A/S	142	178	76	56	43-57	71	360kg
	53A/N							450kg
305	53C/S	161	178	76	75	43-57	71	700kg
307	53FJ/S	215	390	65	88	60	94	2000kg

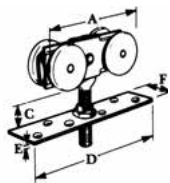

		57						
Track	Hanger Short Code	Dimensions						Max. Door Weight
		A	C	D	E	F		
290	57K/N							150kg
	57K/S 200	87	31	140	5	25		200kg
301	57A/S	142	57	184	6	38		300kg
301H	57A/N	142	57	184	6	38		450kg
305	57C/S	161	61	184	6	38		700kg

Metal Doors

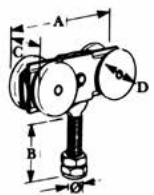

		56						
Track	Hanger Short Code	Dimensions						Max. Door Weight
		A	B	C	D	øD		
290	56K/N							150kg
	56K/S	87	32	27	37	10		150kg
	56K/S 200							200kg
301	56A/S	142	70	42	56	16		300kg
	56A/N							400kg
301H	56A/S	142	70	42	56	16		360kg
	56A/N							450kg
305	56C/S	161	70	42	75	16		700kg
307	56FJ/S	215	86	55	88	20		2000kg

Metal Doors

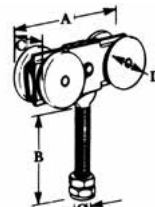

		56x						
Track	Hanger Short Code	Dimensions						Max. Door Weight
		A	B	C	D	øD		
290	56KX/N	87	110	27	37	10		150kg
	56KX/S							200kg
301	56AX/S	142	146	42	56	16		300kg
	56AX/N							400kg
301H	56AX/S	142	146	42	56	16		360kg
	56AX/N							450kg
305	56CX/S	161	146	42	75	16		700kg
307	56FJX/S	215	140	55	88	20		2000kg

Folding Doors

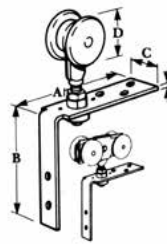

		21					
Track	Hanger Short Code	Dimensions					Max. Door Weight
		A	B	C	D	E	
290	21K/S						
	21K/N	153	153	25	37	5	
	21K/4N						
301	21A/S	178	153	38	56	6	
301H	21A/4S						
305	21C/S	178	153	38	56	6	

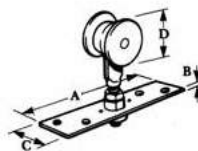

		61				
Track	Hanger Short Code	Dimensions				Max. Door Weight
		A	B	C	D	
290	62K/S	140	5	25	37	
301 and 301H	61A/S	184	6	38	56	
305	61C/S	184	6	38	75	

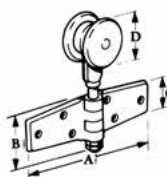

		62				
Track	Hanger Short Code	Dimensions				Max. Door Weight
		A	B	C	D	
290	62K	180	77	45	37	
301 & 301H	62A	180	77	45	56	

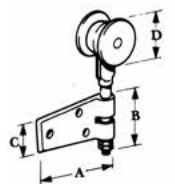

		63				
Track	Hanger Short Code	Dimensions				Max. Door Weight
		A	B	C	D	
290	63K	90	77	45	37	
301 & 301H	63A	90	77	45	56	

Fire Doors

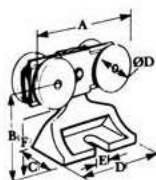

		56F							
Track	Hanger Short Code	Dimensions						Max. Door Weight	
		A	B	C	D	øD	E		F
301	56AF/S	142	70	45	50	56	16	42	300kg
301 & 301H	56AF/S	142	70	45	50	56	16	42	400kg
305	56CF/S	161	89	45	83	75	17	51	700kg

Industrial Channel and Rail Drawings

Dimensions (mm)

Component	89	94	97	100	900	99	13	917	918	297	298	299
A	25	20	38	27	29	38	60	13	10	65	51	51
B	24	21	27	27	45	46	65	35	25	55	51	32
C	3	1.5	3	3	2	3	3	2	2	7	4	3

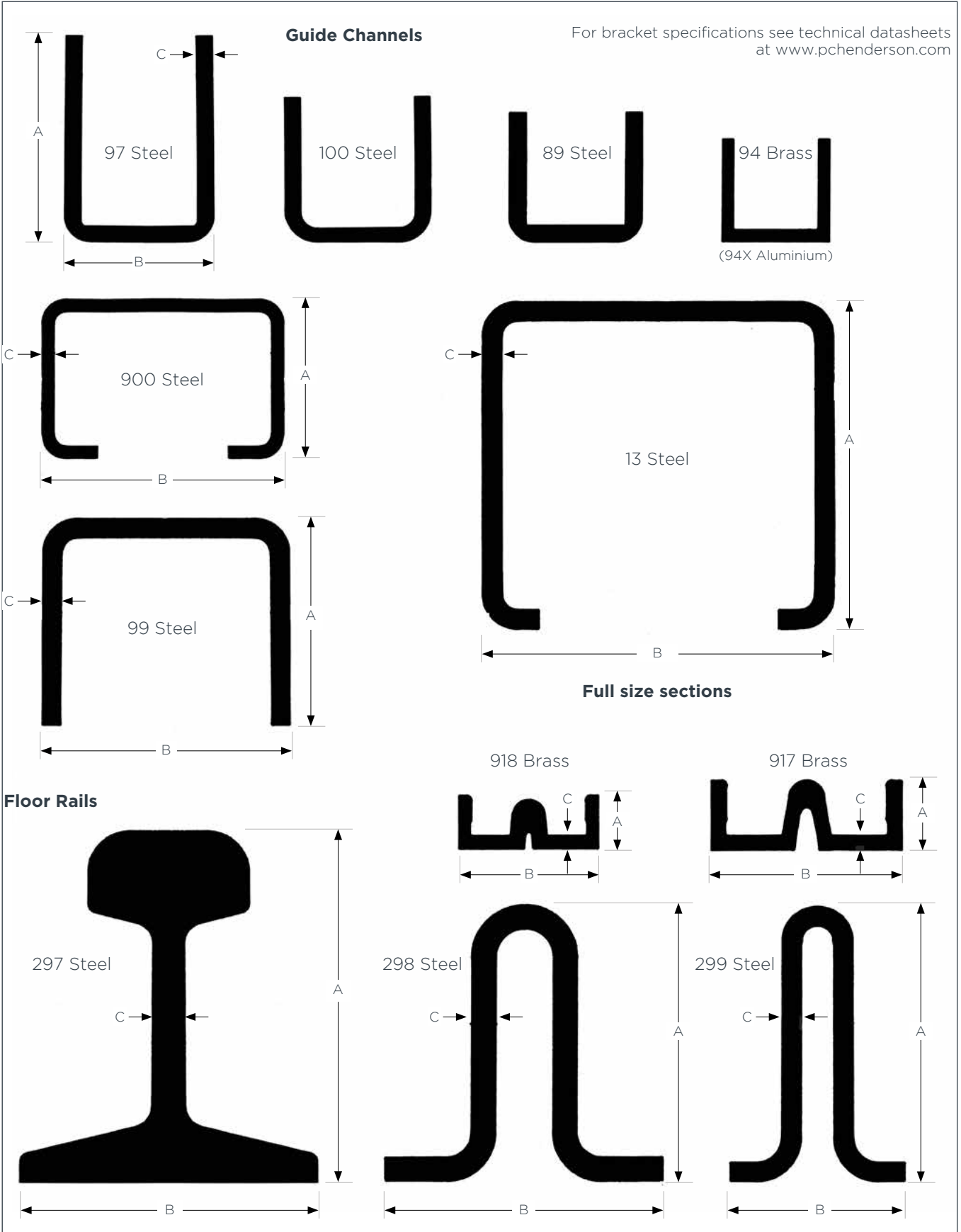

Stainless Steel Component Drawings

For areas exposed to extreme levels of corrosive elements or where a high level of hygiene is essential, P C Henderson has developed a stainless steel range specifically for this purpose. Manufactured from high quality stainless steel and incorporating the latest polymers, the range can be used for a variety of applications including chemical factories, oil rigs, abattoirs, cold storage, food processing plants and areas exposed to salt water.

Stainless Steel product information can be found on pages 52 and 53.

Stainless Steel Track, Guide Channel and Guide Drawings

Track

Track	Dimensions (mm)			Capacities for Straight Sliding Doors		
	A	B	C	Door Thickness	Max. Door Height	Max. Door Weight
280/SS	28.5	31.7	1	20 - 50mm	2400mm	50/100kg
290/SS	45	39	1.5	35 - 48mm	3000mm	150kg
301/SS	68	56	2.5	43 - 57mm	3600mm	270kg

All track and channels are made out of grade 316L (A4) stainless steel and supplied in 2000 or 3000mm lengths.

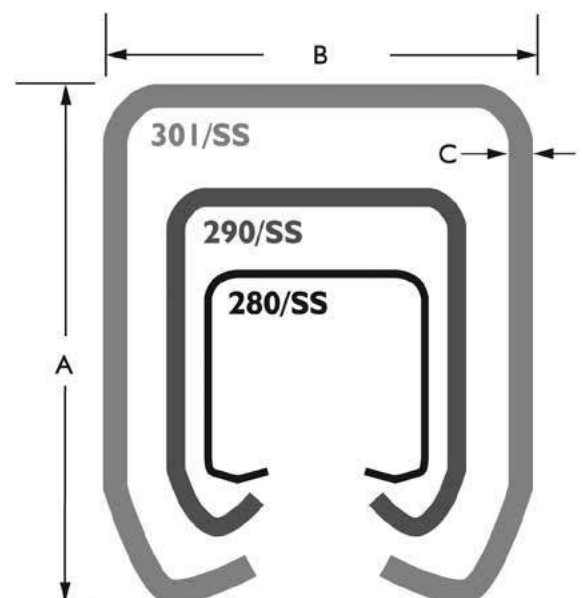

Channel

Channel	Dimensions (mm)		
	A	B	C
89/SS	20.5	20	1.5

Guides and guide channels are essential for stability, safety and functioning of the system.

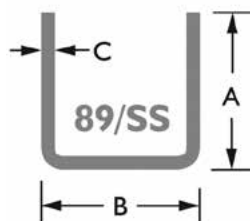

Guides

31S/SS

Made with grade 316 (A4) stainless steel angle and horizontal adjustable nylon guiding wheels on grade 304 (A2) stainless steel bolts. The guide provides unhindered access and is suitable for applications where dirt might enter the guide channel and hinder sliding.

Dimensions (mm)							
A	B	C	D	E	F	G	H
135	50	115	11	25	22	60	4

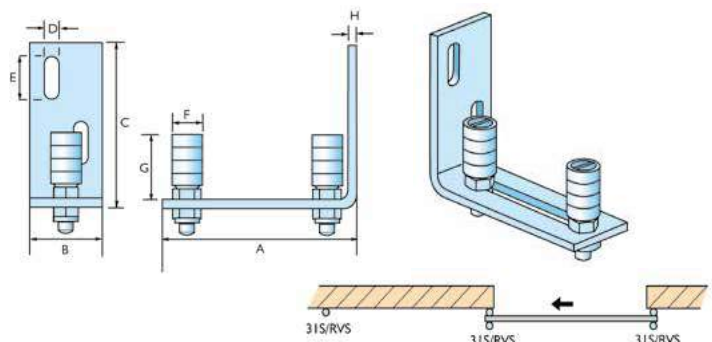

89/2N/SS

Torpedo guide must be used in conjunction with 89/SS guide channel rebated in door or fixed to underside of door.

Dimensions (mm)							
A	B	C	D	E	F	G	H
9	16	150	80	35	48	54	25

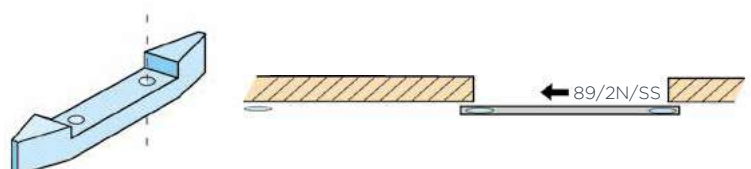

Stainless Steel Bracket and Stop Drawings

The centre-to-centre distance of the brackets can vary depending on track length. Recommended spacing is 600mm and in case of maximum load 500mm.

Joining brackets are required at each track joint, the letter X indicates the joining bracket e.g. 1X/SS.

Should the stainless steel brackets or track be fitted directly to a material which is not stainless steel, it is recommended that a packing be placed between the two surfaces to avoid possible contact corrosion. All brackets are made in marine grade 316 (A4) stainless steel, all nuts and bolts in grade 304 (A2) stainless steel.

Face Fixed Brackets

1/SS						
Short Code	Dimensions (mm)					Bolt
	A	B	C	D	E	
281/SS	20	7	28	40	-	M5
1/290/SS	86	20	50	42	25	M8
1/301/SS	110	27	66	66	33	M10

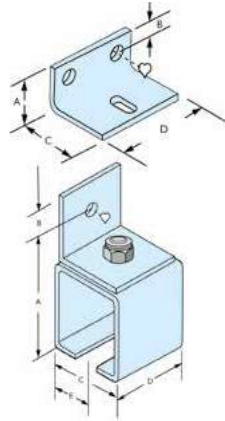

1X/SS						
Short Code	Dimensions (mm)					Bolt
	A	B	C	D	E	
1X/290/SS	86	20	50	100	25	M8
1X/301/SS	110	27	66	113	33	M10

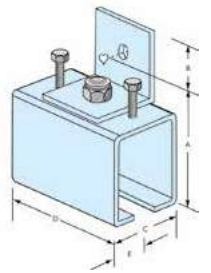

3/SS						
Short Code	Dimensions (mm)					Bolt
	A	B	C	D	E	
3/290/SS	76	-	88	40	65	M8
3/301/SS	99	-	136	60	106	M10

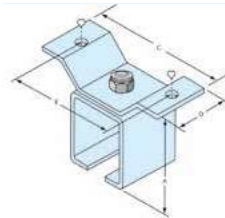

3X/SS							
Short Code	Dimensions (mm)					Bolt	
	A	B	C	D	E		F
3X/290/SS	76	-	88	40	65	-	M8
3X/301/SS	99	-	136	60	106	-	M10

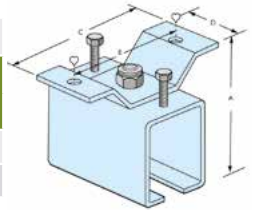

4/SS						
Short Code	Dimensions (mm)					Bolt
	A	B	C	D	E	
4/290/SS	76	-	40	88	65	M8
4/301/SS	99	-	60	136	106	M10

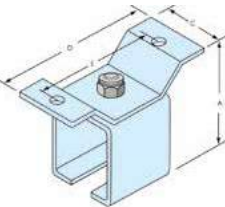

4R/SS					
Short Code	Dimensions (mm)				Bolt
	A	B	C	D	
4R/280/SS	50	50	37	39	M8
4R/290/SS	50	42	50	56	M10
4R/301/SS	65	66	66	80	M10

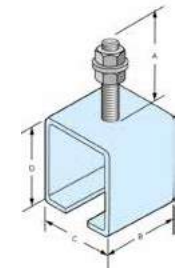

4X/SS					
Short Code	Dimensions (mm)				Bolt
	A	B	C	D	
4X/290/SS	-	100	50	56	M10
4X/301/SS	-	113	66	80	M12

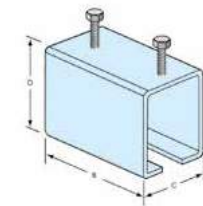

4RX/SS					
Short Code	Dimensions (mm)				Bolt
	A	B	C	D	
4RX/280/SS	50	50	37	39	M8
4RX/290/SS	50	100	50	56	M10
4RX/301/SS	65	113	66	80	M12

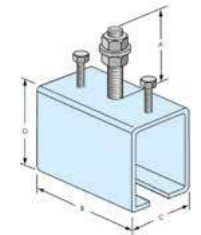

HH3/SS			
Short Code	Dimensions (mm)		
	A	B	C
HH3/290/SS	40	40	5
HH3/301/SS	40	40	5

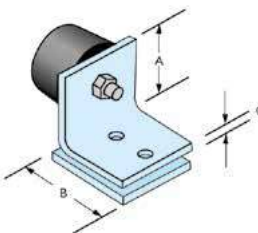

109/SS			
Short Code	Dimensions (mm)		
	A	B	C
109/SS	63	50	14

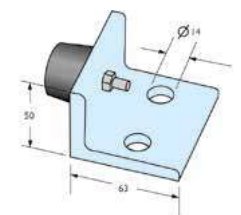

Stainless Steel Hanger Drawings

284 and 285

Short Code	Track Type	Door Material	Dimensions (mm)					Max. Door Weight*
			A	B	C	D	ø	
284N/SS	280	Wood	62.5	27.5	21	80	8	50kg
285N/SS	280	Metal	62.5	27.5	-	-	8	50kg
284/SS	280	Wood	62.5	27.5	21	80	8	100kg
285/SS	280	Metal	62.5	27.5	-	-	8	100kg

Hanger body and wheels in high performance nylon.
All metal components in grade 304 (A2) stainless steel.

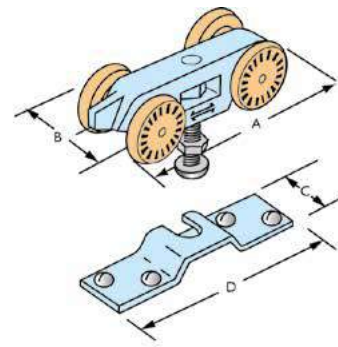

53

Short Code	Track Type	Door Material	Dimensions (mm)						Max. Door Weight*
			A	B	C	D	E	F	
53/290/SS**	290	Wood	87	180	77	37	43/58	3	150kg
53/301/SS***	301	Wood	135	180	77	49.5	43/53	3	270kg

** Hanger body in high performance nylon.
All other components in grade 304 (A2) stainless steel

*** Complete in grade 304 (A2) stainless steel

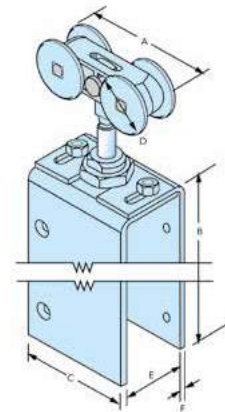

56

Short Code	Track Type	Door Material	Dimensions (mm)					Max. Door Weight*
			A	B	C	D	ø	
56/290/SS**	290	Metal	87	40	30	37	M10	150kg
56/301/SS***	301	Metal	135	78	43	49.5	M16	270kg

**Hanger body in high performance nylon.
All other components in grade 304 (A2) stainless steel

*** Complete in grade 304 (A2) stainless steel

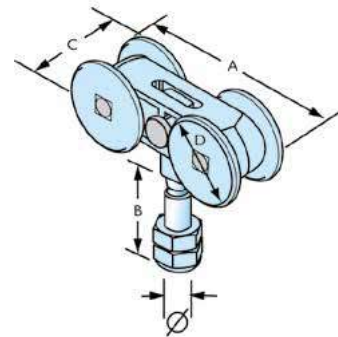

57

Short Code	Track Type	Door Material	Dimensions (mm)					Max. Door Weight*
			A	B	C	D	E	
57/290/SS**	290	Wood	87	39	187	3	37	150kg
57/301/SS***	301	Wood	135	39	187	3	49.5	270kg

**Hanger body in high performance nylon.
All other components in grade 304 (A2) stainless steel

*** Complete in grade 304 (A2) stainless steel

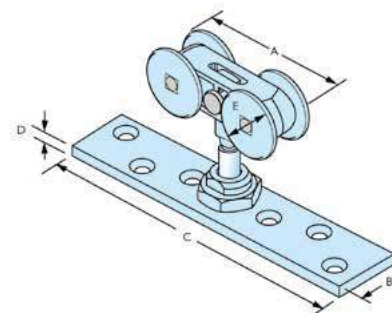

*The maximum weight of each door carried by two hangers

Accessories

SOFT CLOSE KITS



R80SOFT

For use with either of our Rustic systems. Can be installed onto new or existing applications

SIMULTANEOUS ACTION KITS

NEW



SIM100

For use with existing or new Husky 100, Pocket Door and Pocket Door Pro products. Open/close one door and the other will open/close simultaneously.

SELF CLOSE KITS



SC100

Pneumatic door closer for sliding doors up to 100kg



SCK1

For use with any Marathon kit



BISELF For use with Pocket Door Pro and Soltaire

If Using Without a Simultaneous Action Kit
Please purchase x2 BISELF kits

Is Using With a Simultaneous Action Kit
For doors 0-50kg: Please purchase x1 BISELF kit
For doors 50 - 80kg: Please purchase x2 BISELF kits.

FLUSH PULLS AND FINGER PULLS

NEW



26P

White plastic flush pull, Ø40mm



144S

Satin oval flush pull, 144mm (h) x 44mm (w)



385/P

Polished brass flush pull set, Ø57mm



27 (for 6mm glass doors)

Aluminium flush pull, Ø29mm



125/S

Satin rectangular flush pull, 125mm (h) x 39mm (w)



385/B

Black flush pull set, Ø57mm



EDGE/S

Satin pull for door edge, 52mm (h) x 29mm (w)



125/C

Chrome rectangular flush pull, 125mm (h) x 39mm (w)



385EDGE/S

Satin flush pull and door edge pull set, Ø57mm



EDGE/C

Chrome pull for door edge, 52mm (h) x 29mm (w)



400

SAA rectangular flush pull, 108mm (h) x 48mm (w)



385EDGE/C

Chrome flush pull and door edge pull set, Ø57mm



380/S

Satin finger pull for door edge, Ø29mm



400SS

SS rectangular flush pull, 108mm (h) x 48mm (w)



385EDGE/B

Chrome flush pull and door edge pull set, Ø57mm



380/P

Polished brass finger pull for door edge, Ø29mm



413

Cast iron heavy duty flush pull, 152mm (h) x 95mm (w)



53/S

Satin square flush pull set, 53mm (h & w)



380/C

Chrome finger pull for door edge, Ø29mm



414

Aluminium heavy duty flush pull, 133mm (h) x 60mm (w)



53/C

Chrome square flush pull set, 53mm (h & w)



380/B

Black finger pull for door edge, Ø29mm



385/S

Satin flush pull set, Ø57mm



53/B

Black square flush pull set, 53mm (h & w)



144B

Black oval flush pull, 144mm (h) x 44mm (w)



385/C

Chrome flush pull set, Ø57mm

All dimensions refer to the visible outer measurements of the hardware. Inner dimensions for installation can be found in the fitting instructions.

HANDLES



463

Cast iron bow handle,
159mm (h) x 46mm (w)



464

Cast iron handle, 261mm
(h) x 62mm (w)



SF10S

Satin handle for folding doors 118mm (h)
x 16mm (w) x 45mm (d)



SF10C

Chrome handle for folding doors 118mm
(h) x 16mm (w) x 45mm (d)



SF10G

Gold handle for folding doors 118mm (h)
x 16mm (w) x 45mm (d)



SF10B

Black handle for folding doors 118mm
(h) x 16mm (w) x 45mm (d)



TWINHAN/S

Handle for use with Twinbolt

LOCKS

NEW



390/S

Satin lockable flush pull set for doors
35 - 52mm thick, Ø60mm



390/C

Chrome lockable flush pull set for doors
35 - 52mm thick, Ø60mm



571/S

Satin lockable flush pull set with indicator, for
doors 40 - 45mm thick, Ø57mm



571/C

Chrome lockable flush pull set with indicator,
for doors 40 - 45mm thick, Ø57mm



60SQ/S

Satin lockable square flush pull set for doors
35 - 52mm thick, 60mm (h & w)



60SQ/C

Chrome lockable square flush pull set for
doors 35 - 52mm thick, 60mm (h & w)



507 (for glass panels)

Chrome cylinder lock for 4mm or
6mm thick glass panels



507/120 (for glass panels)

Chrome cylinder lock for 4mm or
6mm thick glass panels, keyed alike

FLUSH BOLTS LOCKING AND NON LOCKING



333
Non locking, satin anodised aluminium,
151mm (h) x 35mm (w)



454
Non locking, satin anodised aluminium,
190mm (h) x 41mm (w)



FB110S
Non locking, 110mm high, suitable for
interior



SF190*
Non lockable, 190mm, available in gold,
chrome, satin or black



SF190L*
Lockable, 190mm, available in gold,
chrome, satin or black



SF450*
Non lockable, 450mm, available in gold,
chrome, satin or black



SF450L*
Lockable, 450mm, available in gold,
chrome, satin or black



SF600*
Non lockable, 600mm, available in gold,
chrome, satin or black



SF600L*
Lockable, 600mm, available in satin or
black

*Replace with first letter of required colour for full short code

TWINBOLT



Twinbolt
Locking system
for use with
Securefold and
Securefold Bottom
Rolling systems.
Top and bottom
throw rods are
operated by one
simple turn to
engage two points
of locking.

TB/SFBR
Twinbolt for Securefold Bottom Rolling
(for mortice and non mortice applications)

TB/SFMBR
Twinbolt for Securefold Bottom Rolling
(for mortice square applications)

TB/SF
Twinbolt for Securefold 50 and 100
(for mortice and non mortice applications)

TB/SFM
Twinbolt for Securefold 50 and 100
(for mortice square applications)

TB/SF150
Twinbolt for Securefold 150



TWINHAN/S
Handle for use
with Twinbolt



TBCS**
Routing cover
strip for use
with Twinbolt

TRACK STOPS



287
For Husky Sliding



287SS
For Stainless Steel 280



HH3/290
With rubber buffer for Straight Sliding
290 and Pacer track



HH3/290SS
Stainless steel with rubber buffer for
Stainless Steel 290



HH3/301
With rubber buffer for Straight Sliding
301 and Flexirol track



HH3/301SS
Stainless steel with rubber buffer, for
Stainless Steel 301



HH4/AN
Anodised aluminium with rubber buffer
for Soltaire 120 track



HH5/AN
Anodised aluminium with rubber buffer
for Soltaire 180 and 250 track

DOOR STOPS



103
Floor mounted



107
Zinc plated steel, double rubber buffers,
floor or wall mounted



107E
Rubber buffer



109
Zinc plated steel, rubber buffer, floor or
wall mounted



110N
White nylon, rubber buffer



28P
White nylon

FANTOM MAGNETIC DOOR STOP NEW

Innovative magnetic door stop solution which sits flush to the floor and is only activated when the door opens over the stop. Ideal for swing doors, pivot doors and sliding doors.



FANTOM/CL
For swing doors, clear



FANTOMSL/CL
For sliding doors, clear



FANTOM/PACK
5mm packer



FANTOM/S
For swing doors, satin



FANTOMSL/S
For sliding doors, satin



FANTOM/INST
5 piece installation kit



FANTOM/B
For swing doors, black



FANTOMSL/B
For sliding doors, black



FANTOM/W
For swing doors, white



FANTOMSL/W
For sliding doors, white



FANTOM/PB
For swing doors,
polished brass



FANTOMSL/PB
For sliding doors,
polished brass



DOOR MAGNETS



MAG/B
Black magnet set for between folding
doors



SWMAG/B
Black magnet set for swing door



MAG/C
Chrome magnet set for between folding
doors



SWMAG/C
Chrome magnet set for swing door



MAG/G
Gold magnet set for between folding
doors



SWMAG/G
Gold magnet set for swing door



MAG/S
Satin magnet set for between folding
doors



SWMAG/S
Satin magnet set for swing door

BOLTS



994
Bolt with electro galvanised steel shoots and guides with socket for concrete when required



994R/89
Galvanised steel roller guide bolt 380mm for 89 channel



994X
Offset bolt with zinc galvanised steel shoot & guides with socket for concrete



994R/97
Galvanised steel roller guide bolt 380mm for 96 channel



F3715
Surface fixed bolt in satin



F3734
Keep for F3715 bolt

FASCIA



F134/****
For Husky and Double Top soffit fixed installations. Available in 2000, 3000, 4000 and 6100mm



F200/****
For Pacer face fixed track. In 2000, 2500, 3000, 3500, 4000 and 6100mm lengths.



F134/ECP
End cap pack for use with F134 Fascia



F200/ECP
End cap pack for use with F200 Fascia



F140/****
For face fixed Husky installations. Available in 1800, 2000, 3000, 4000 and 6000mm



FOR GLASS DOORS

F136/****
For Husky Glass. Available in 2000, 3000 and 4000mm lengths



F140ECP
End cap pack for use with F140 Fascia



F136/ECP
End cap pack for use with F136 Fascia



F160/****
For use with Pacer soffit fixed track. Available in 2000, 2500, 3000, 4000 and 6100mm



F160/ECP
End cap pack for use with F160 Fascia

AUTOMATIC DOOR ACCESSORIES



E2/RCK
Remote Control Kit - includes a single channel remote control and one wireless receiver control panel



ER/*
Radar Motion Sensor - available in black (ER/B), white (ER/W) or satin (ER/S)

*Replace with first letter of required colour for full short code

Global leaders in the design and manufacture of hardware systems for sliding and folding doors



P C Henderson Limited, Durham Road, Bowburn, Co. Durham, DH6 5NG, United Kingdom

HENDERSON

UK

t: +44 (0) 191 377 7345
e: sales@pchenderson.com
w: www.pchenderson.com

Ireland

t: +353 (0) 1643 6816
e: sales@pchenderson.ie
w: www.pchenderson.ie

Netherlands

t: +31 (0) 497 332020
e: sales@henderson.nl
w: www.henderson.nl

Spain

t: +34 916 528 642
e: spain@pchenderson.com
w: www.pchenderson.es

Germany

t: +44 (0) 191 377 7346
e: verkauf@pchenderson.de
w: www.pchenderson.de

South Africa

t: +27 (11) 761 5000
e: southafrica@pchenderson.com
w: www.henderson.co.za

China

t: +86 0512 5770 9708
e: china@pchenderson.com
w: www.pchenderson.cn

Indonesia

t: +62 (021) 6906189
e: info@rb-mandiri.com
w: www.rodabangunmandiri.com

Australia

t: 1300 562 587
e: australia@pchenderson.com
w: www.pchenderson.com.au

Rest of World

t: +44 (0) 191 377 7346
e: international@pchenderson.com
w: export.pchenderson.com



Part of ASSA ABLOY

